

RECOMMENDED P.C.B. LAYOUT

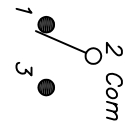

CIRCUIT: SPDT

SWITCH FUNCTION		
PDS. 1	PDS. 2	PDS. 3
DN	OFF	DN
2-3	OPEN	2-1

NOTES:

1. ALL DIMENSIONS IN MM [INCH]
2. GENERAL TOLERANCE: X.X=±0.4
X.XX=±0.25
3. TERM. NOS. FOR REF. ONLY
4. RATING: 0.4(VA) Max. @20V Max. (AC OR DC)
5. FIXED TERM. & MOVING CONTACT:
COPPER ALLOY W/GOLD PLATE OVER NICKLE PLATE.
6. ELECTRICAL LIFE: 50,000 MAKE-AND-BREAK CYCLES AT FULL LOAD.
7. INSULATION RESISTANCE: 1,000M OHM MIN.
8. DIELECTRIC STRENGTH: 1000V RMS @SEA LEVEL
9. OPERATING TEMP.: -30°C to 85°C
10. ▲ DENOTES CRITICAL PARAMETER.
11. 2002/95/EC (ROHS) COMPLIANT
12. HARDWARE TO BE SUPPLIED BULK:
T100020-LOCK WASHER QTY-1
T100017-LOCK RING QTY-1
T100019-HEX NUT QTY-2

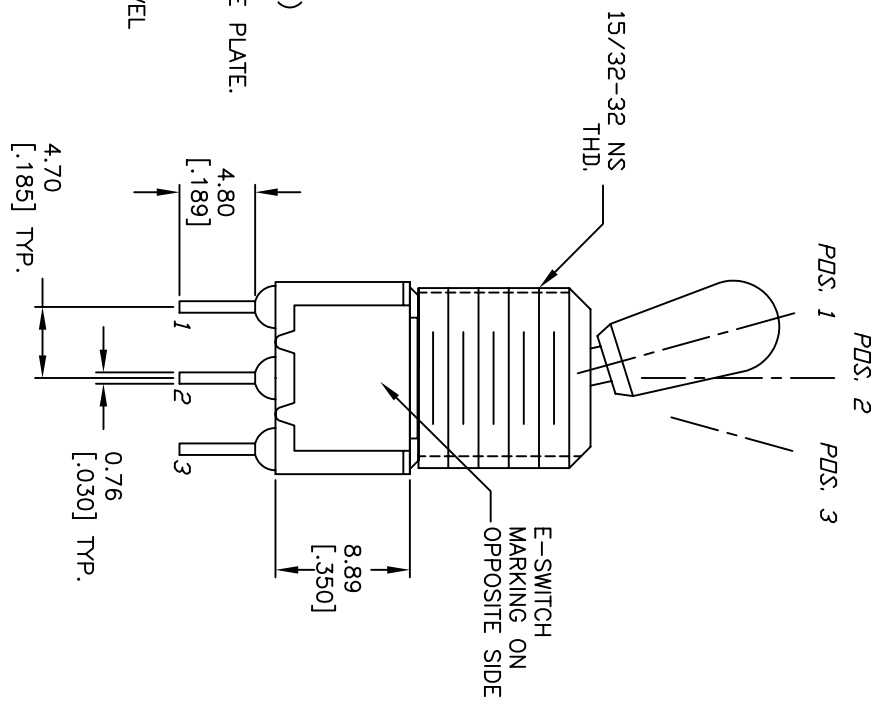
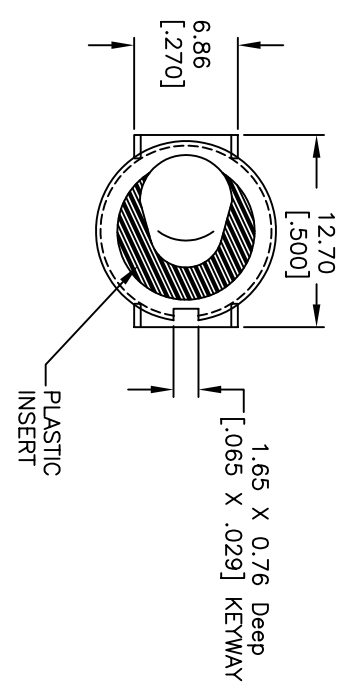

**Measured in UPRIGHT Pos.

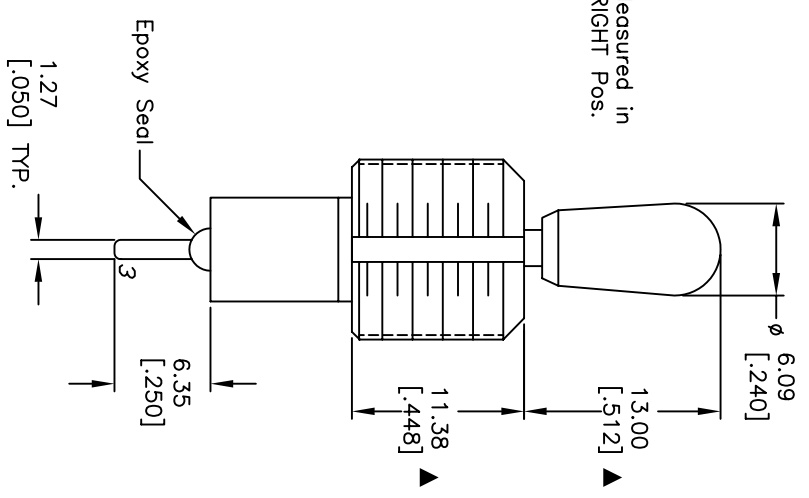

100SP3T7B13M2REH

REV.	ECN No.	DESCRIPTION	DATE	CHKD
A	15497	RELEASED FOR PRODUCTION	11/3/05	PH

TITLE	SCALE	DATE	DR	DWG	REV
100SP3T7B13M2REH	2:1	11/3/05	PH	ST110319	A

THE INFORMATION CONTAINED IN THIS DOCUMENT IS PROPRIETARY TO E-SWITCH AND IS NOT TO BE COPIED OR TRANSMITTED