

| LOC |   | DIST |     | REVISIONS               |           |     |      |
|-----|---|------|-----|-------------------------|-----------|-----|------|
| FT  | 0 | P    | LTR | DESCRIPTION             | DATE      | DWN | APVD |
|     |   | A    |     | REVISED EC 063B-0941-03 | 17MAR2004 | SW  | SY   |

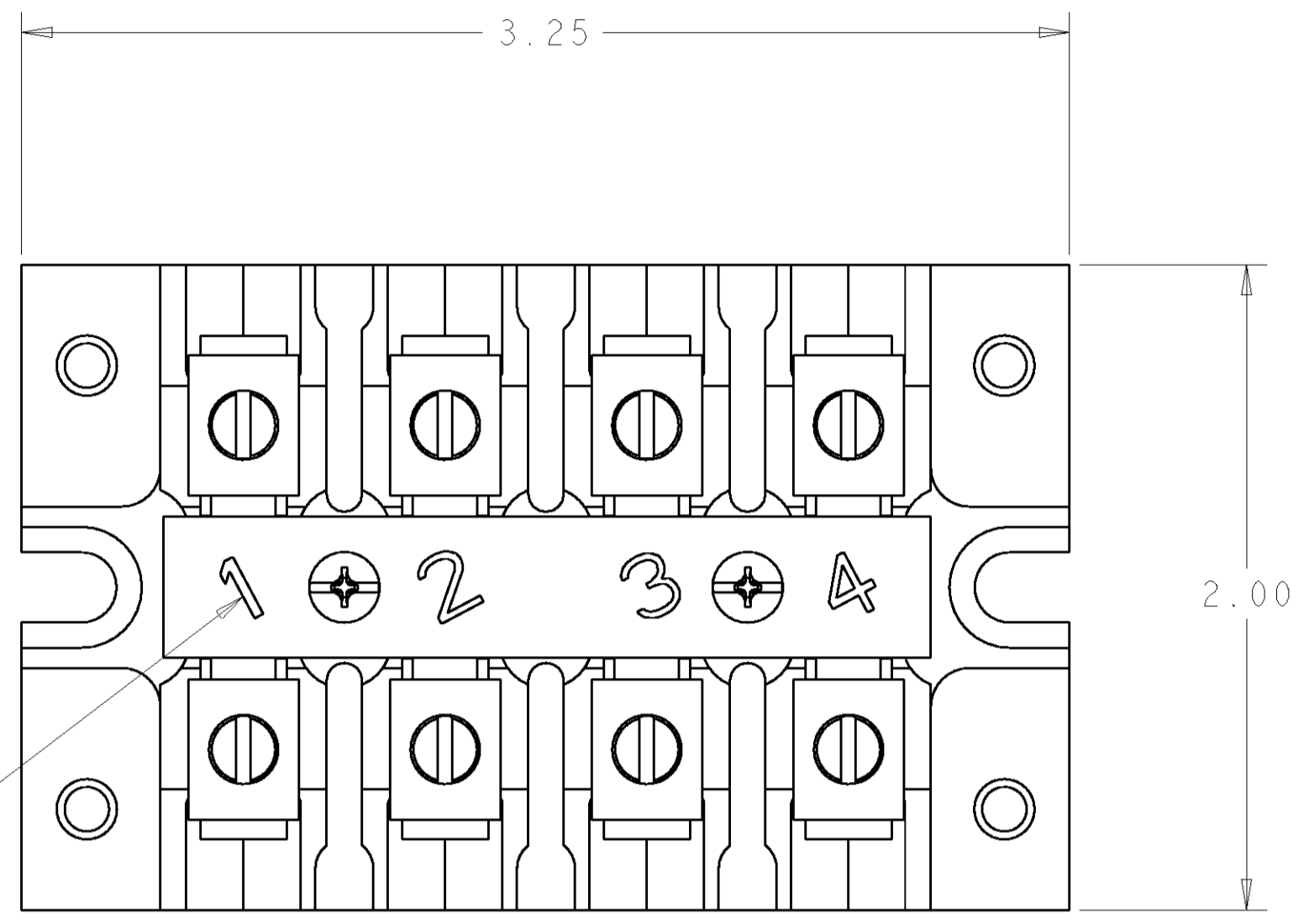

MARKING, SEE TABLE

1. ALL PARTS TO BE ASSEMBLED AS SHOWN.  
 △ CHARACTERS INK STAMPED WHITE ON BLACK SIDE OF MARKING STRIP.

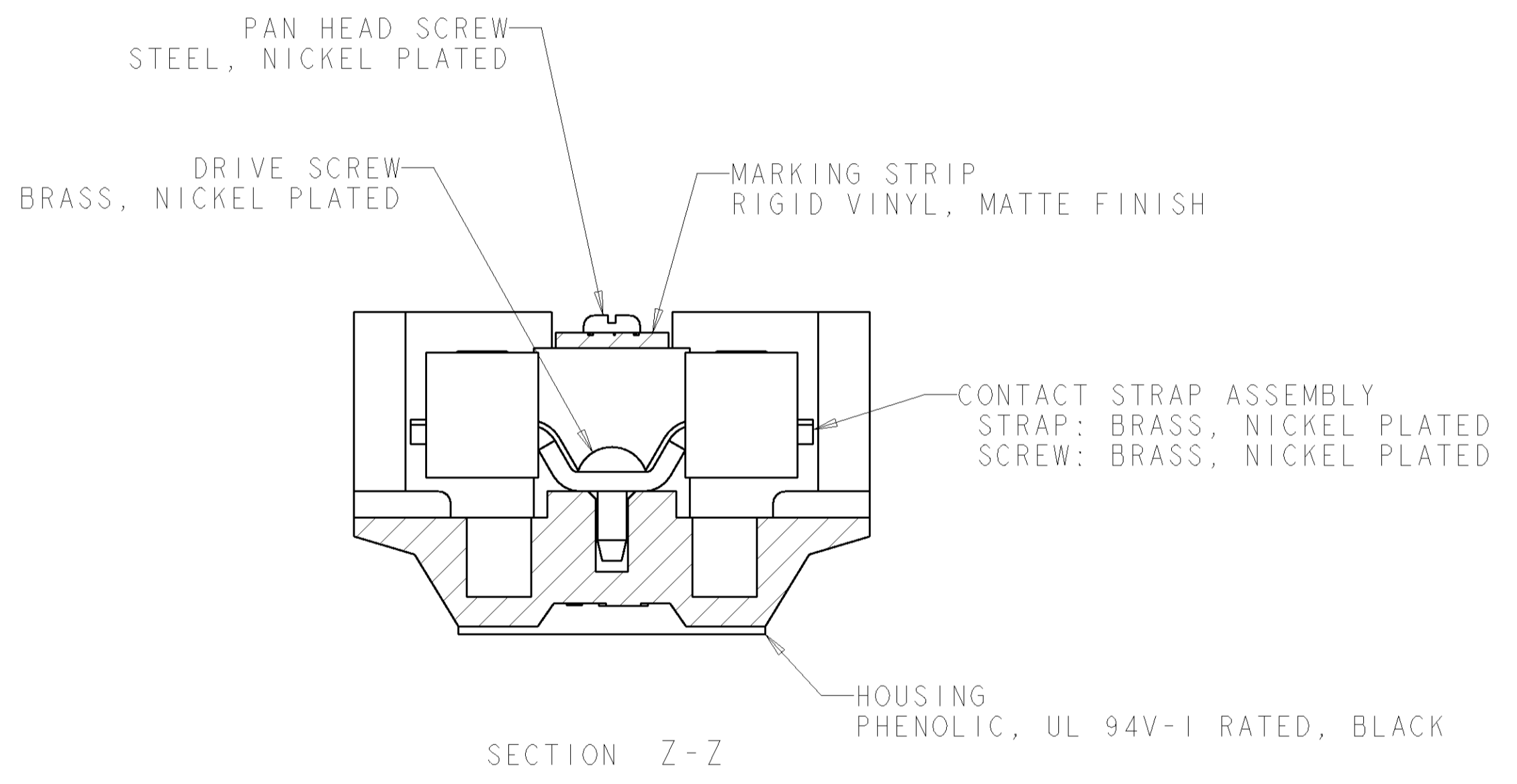
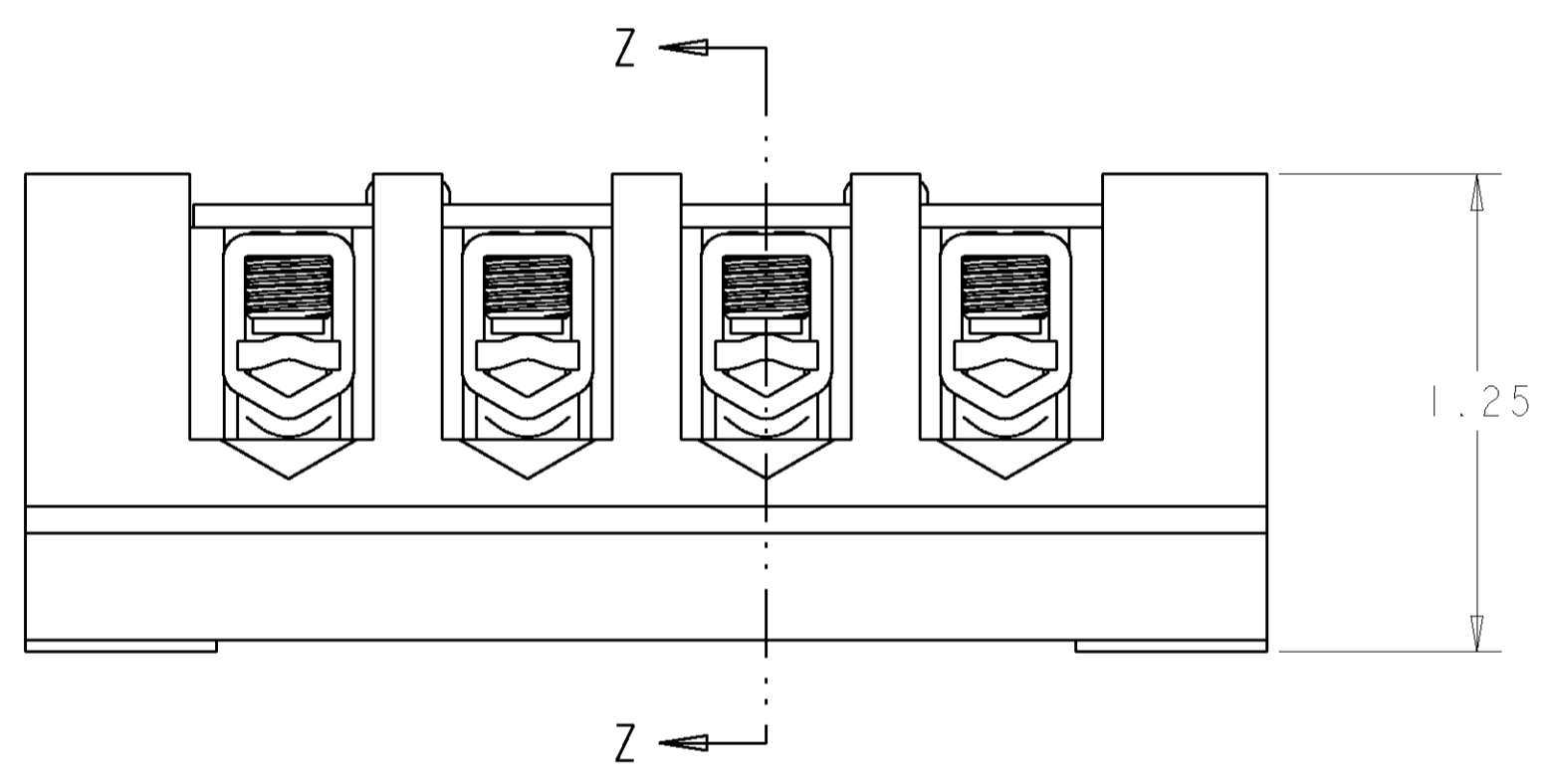

|          |         |            |                |             |
|----------|---------|------------|----------------|-------------|
| OBSOLETE | △       | 4          | B104SN         | 3-1437382-8 |
| -        | -       | 4          | B104S          | 3-1437382-6 |
| STATUS   | MARKING | NO OF POSN | CATALOG NUMBER | PART NUMBER |

| DIMENSIONS: |  | TOLERANCES UNLESS OTHERWISE SPECIFIED: |         | DWN           |           | BUCHANAN                  |  | Tyco Electronics                      |  |
|-------------|--|--|---------|---------------|-----------|---------------------------|--|---------------------------------------|--|
| INCHES      |  | 0 PLC                                  | ±       | S. WELDON     | 17MAR2004 | Harrisburg, PA 17105-3608 |  | -                                     |  |
|             |  | 1 PLC                                  | ±0.0    | CHK S. YODER  | 17MAR2004 | NAME                      |  | BLOCK ASSEMBLY, ONE PIECE, .625 PITCH |  |
|             |  | 2 PLC                                  | ±0.01   | APVD S. YODER | 17MAR2004 | PRODUCT SPEC              |  | -                                     |  |
|             |  | 3 PLC                                  | ±0.005  |               |           | APPLICATION SPEC          |  | -                                     |  |
|             |  | 4 PLC                                  | ±0.0000 |               |           | WEIGHT                    |  | -                                     |  |
|             |  | ANGLES                                 | ±       |               |           | CUSTOMER DRAWING          |  | -                                     |  |
| MATERIAL    |  | FINISH                                 |         |               |           | SCALE                     |  | 2:1                                   |  |
|             |  |  |         |               |           | SHEET                     |  | 1 OF 1                                |  |
|             |  |  |         |               |           | REV                       |  | A                                     |  |