

IRG7PH30K10PbF

INSULATED GATE BIPOLAR TRANSISTOR

Features

- Low $V_{CE(ON)}$ Trench IGBT Technology
- Low Switching Losses
- Maximum Junction Temperature 175 °C
- 10 μ S short Circuit SOA
- Square RBSOA
- 100% of the parts tested for I_{LM} ①
- Positive $V_{CE(ON)}$ Temperature Co-Efficient
- Tight Parameter Distribution
- Lead Free Package

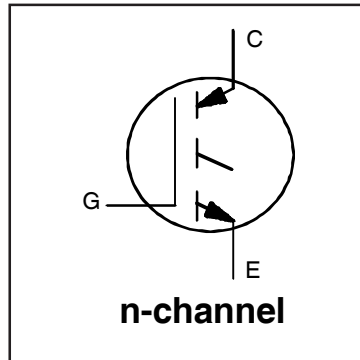

$V_{CES} = 1200V$
$I_C = 23A, T_C = 100^\circ C$
$t_{SC} \geq 10\mu s, T_{J(max)} = 175^\circ C$
$V_{CE(on)} \text{ typ.} = 2.05V$

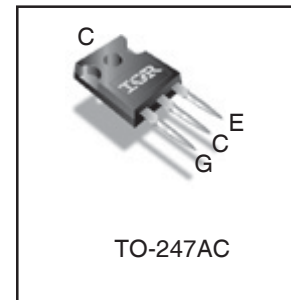

Benefits

- High Efficiency in a Wide Range of Applications
- Suitable for a Wide Range of Switching Frequencies due to Low $V_{CE(ON)}$ and Low Switching Losses
- Rugged Transient Performance for Increased Reliability
- Excellent Current Sharing in Parallel Operation

G	C	E
Gate	Collector	Emitter

Absolute Maximum Ratings

	Parameter	Max.	Units
V_{CES}	Collector-to-Emitter Voltage	1200	V
$I_C @ T_C = 25^\circ C$	Continuous Collector Current	33	A
$I_C @ T_C = 100^\circ C$	Continuous Collector Current	23	
$I_{NOMINAL}$	Nominal Current	9.0	
I_{CM}	Pulse Collector Current $V_{ge} = 15V$	27	
I_{LM}	Clamped Inductive Load Current $V_{ge} = 20V$ ①	36	
V_{GE}	Continuous Gate-to-Emitter Voltage	± 30	V
$P_D @ T_C = 25^\circ C$	Maximum Power Dissipation	210	W
$P_D @ T_C = 100^\circ C$	Maximum Power Dissipation	110	
T_J	Operating Junction and	-55 to +175	°C
T_{STG}	Storage Temperature Range		
	Soldering Temperature, for 10 sec.		
	Mounting Torque, 6-32 or M3 Screw	10 lbf-in (1.1 N-m)	

Thermal Resistance

	Parameter	Min.	Typ.	Max.	Units
$R_{\theta JC}$ (IGBT)	Thermal Resistance Junction-to-Case-(each IGBT) ②	—	—	0.70	°C/W
$R_{\theta CS}$	Thermal Resistance, Case-to-Sink (flat, greased surface)	—	0.24	—	
$R_{\theta JA}$	Thermal Resistance, Junction-to-Ambient (typical socket mount)	—	40	—	

Electrical Characteristics @ T_J = 25°C (unless otherwise specified)

	Parameter	Min.	Typ.	Max.	Units	Conditions	Ref.Fig
V _{(BR)CES}	Collector-to-Emitter Breakdown Voltage	1200	—	—	V	V _{GE} = 0V, I _C = 250μA ③	CT6
ΔV _{(BR)CES/ΔT_J}	Temperature Coeff. of Breakdown Voltage	—	1.27	—	V/°C	V _{GE} = 0V, I _C = 1mA (25°C-175°C) ③	CT6
V _{CE(on)}	Collector-to-Emitter Saturation Voltage	—	2.05	2.35	V	I _C = 9.0A, V _{GE} = 15V, T _J = 25°C ②	5,6,7
		—	2.56	—		I _C = 9.0A, V _{GE} = 15V, T _J = 150°C ②	8,9,10
		—	2.65	—		I _C = 9.0A, V _{GE} = 15V, T _J = 175°C ②	
V _{GE(th)}	Gate Threshold Voltage	5.0	—	7.5	V	V _{CE} = V _{GE} , I _C = 400μA	8,9
ΔV _{GE(th)/ΔT_J}	Threshold Voltage temp. coefficient	—	-16	—	mV/°C	V _{CE} = V _{GE} , I _C = 400μA (25°C - 175°C)	10,11
g _{fe}	Forward Transconductance	—	6.2	—	S	V _{CE} = 50V, I _C = 9.0A, PW = 80μs	
I _{CES}	Collector-to-Emitter Leakage Current	—	1.0	25	μA	V _{GE} = 0V, V _{CE} = 1200V	
		—	400	—		V _{GE} = 0V, V _{CE} = 1200V, T _J = 175°C	
I _{GES}	Gate-to-Emitter Leakage Current	—	—	±100	nA	V _{GE} = ±30V	

Switching Characteristics @ T_J = 25°C (unless otherwise specified)

	Parameter	Min.	Typ.	Max.	Units	Conditions	Ref.Fig
Q _g	Total Gate Charge (turn-on)	—	45	68	nC	I _C = 9.0A ②	18
Q _{ge}	Gate-to-Emitter Charge (turn-on)	—	8.7	13		V _{GE} = 15V	CT1
Q _{gc}	Gate-to-Collector Charge (turn-on)	—	20	30		V _{CC} = 600V	
E _{on}	Turn-On Switching Loss	—	530	760	μJ	I _C = 9.0A, V _{CC} = 600V, V _{GE} = 15V ②	CT4
E _{off}	Turn-Off Switching Loss	—	380	600		R _G = 22Ω, L = 1000μH, L _S = 150nH, T _J = 25°C	
E _{total}	Total Switching Loss	—	910	1360		Energy losses include tail & diode reverse recovery	
t _{d(on)}	Turn-On delay time	—	14	31	ns	I _C = 9.0A, V _{CC} = 600V, V _{GE} = 15V ②	CT4
t _r	Rise time	—	24	41		R _G = 22Ω, L = 1000μH, L _S = 150nH, T _J = 25°C	
t _{d(off)}	Turn-Off delay time	—	110	130			
t _f	Fall time	—	38	56			
E _{on}	Turn-On Switching Loss	—	850	—	μJ	I _C = 9.0A, V _{CC} = 600V, V _{GE} = 15V ②	12,14
E _{off}	Turn-Off Switching Loss	—	750	—		R _G = 22Ω, L = 1000μH, L _S = 150nH, T _J = 175°C	CT4
E _{total}	Total Switching Loss	—	1600	—		Energy losses include tail & diode reverse recovery	WF1, WF2
t _{d(on)}	Turn-On delay time	—	12	—	ns	I _C = 9.0A, V _{CC} = 600V, V _{GE} = 15V ②	13,15
t _r	Rise time	—	23	—		R _G = 22Ω, L = 1000μH, L _S = 150nH	CT4
t _{d(off)}	Turn-Off delay time	—	130	—		T _J = 175°C	WF1
t _f	Fall time	—	270	—			WF2
C _{ies}	Input Capacitance	—	1070	—	pF	V _{GE} = 0V	17
C _{oes}	Output Capacitance	—	63	—		V _{CC} = 30V	
C _{res}	Reverse Transfer Capacitance	—	26	—		f = 1.0Mhz	
RBSOA	Reverse Bias Safe Operating Area	FULL SQUARE				T _J = 175°C, I _C = 36A V _{CC} = 960V, V _p = 1200V R _G = 10Ω, V _{GE} = +20V to 0V, T _J = 175°C	4 CT2
SCSOA	Short Circuit Safe Operating Area	10	—	—	μs	V _{CC} = 600V, V _p = 1200V, T _J = 150°C, R _G = 22Ω, V _{GE} = +15V to 0V	16, CT3 WF4

Notes:

- ① V_{CC} = 80% (V_{CES}), V_{GE} = 20V, L = 200μH, R_G = 51Ω.
- ② Pulse width ≤ 400μs; duty cycle ≤ 2%.
- ③ Refer to AN-1086 for guidelines for measuring V_{(BR)CES} safely.
- ④ R_θ is measured at T_J of approximately 90°C.

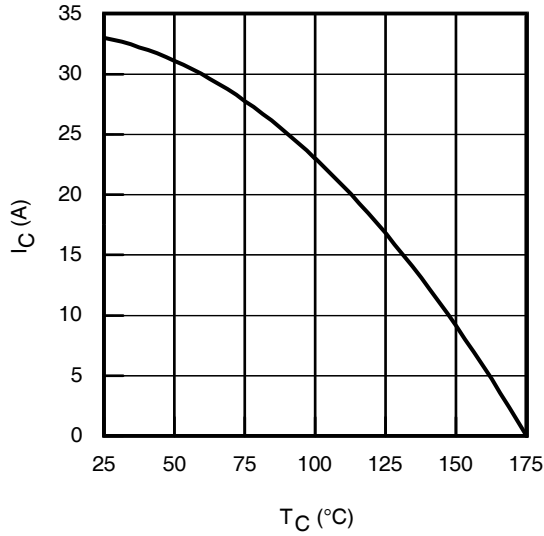

Fig. 1 - Maximum DC Collector Current vs. Case Temperature

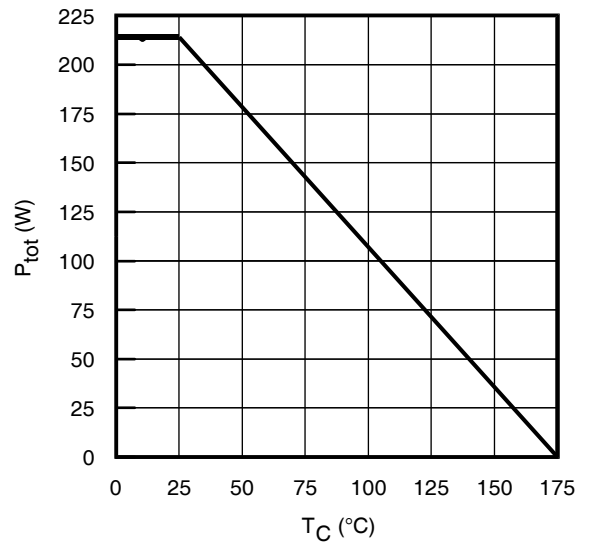

Fig. 2 - Power Dissipation vs. Case Temperature

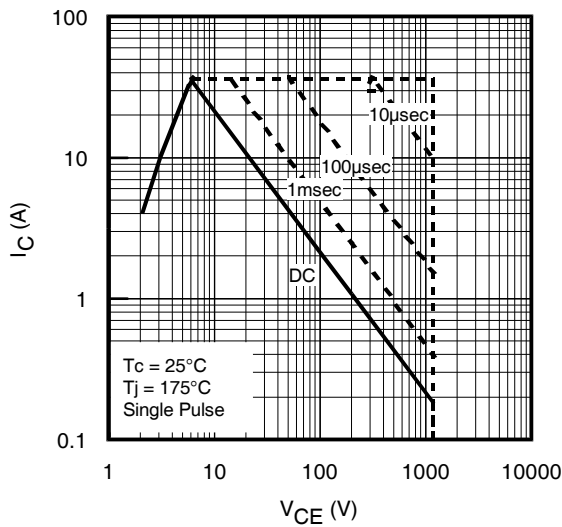

Fig. 3 - Forward SOA
 $T_C = 25^\circ\text{C}$, $T_J \leq 175^\circ\text{C}$; $V_{GE} = 15\text{V}$

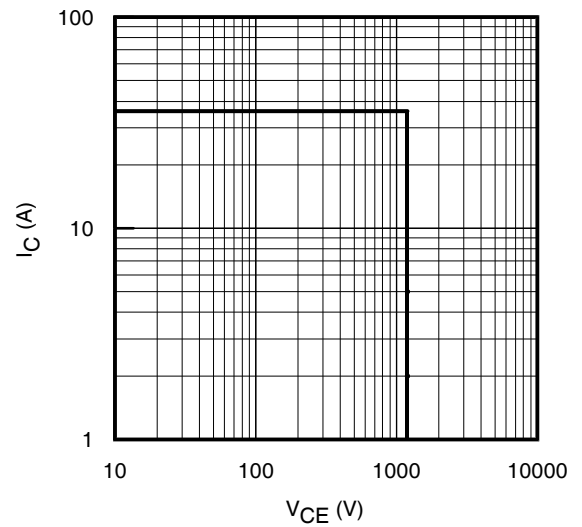

Fig. 4 - Reverse Bias SOA
 $T_J = 175^\circ\text{C}$; $V_{GE} = 20\text{V}$

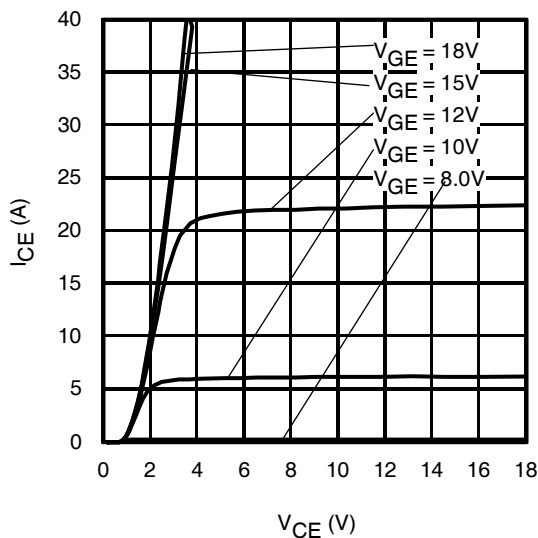

Fig. 5 - Typ. IGBT Output Characteristics
 $T_J = -40^\circ\text{C}$; $t_p = 80\mu\text{s}$

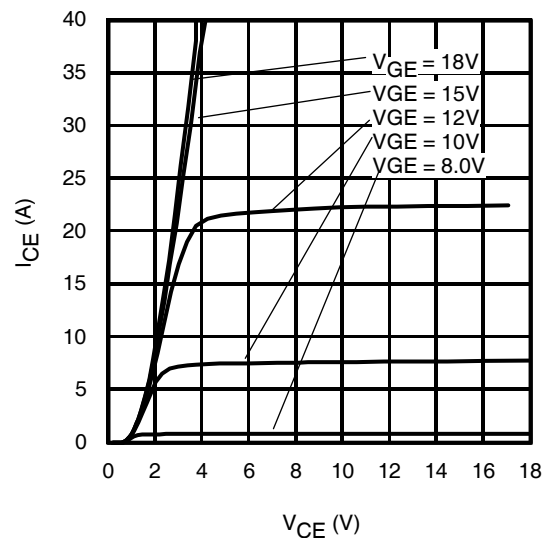

Fig. 6 - Typ. IGBT Output Characteristics
 $T_J = 25^\circ\text{C}$; $t_p = 80\mu\text{s}$

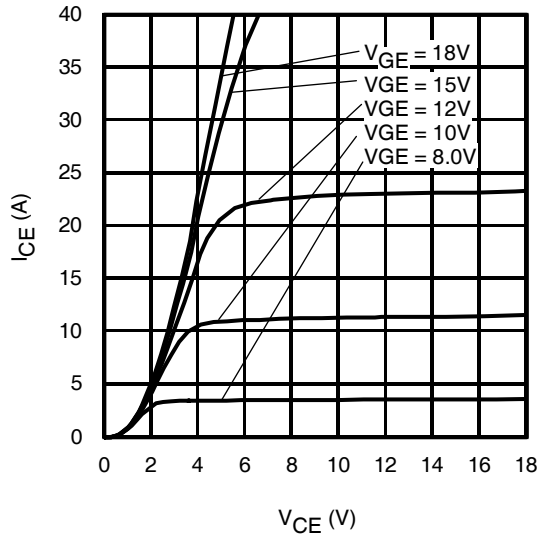

Fig. 7 - Typ. IGBT Output Characteristics
 $T_J = 175^\circ\text{C}$; $t_p = 80\mu\text{s}$

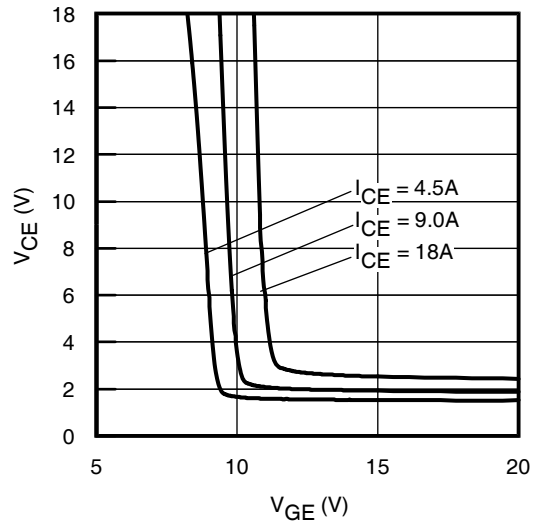

Fig. 8 - Typical V_{CE} vs. V_{GE}
 $T_J = -40^\circ\text{C}$

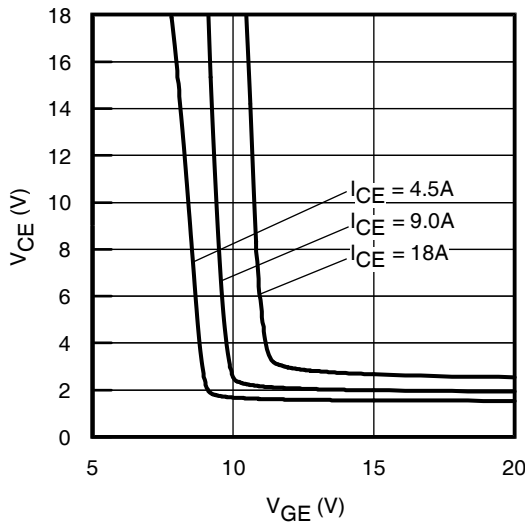

Fig. 9 - Typical V_{CE} vs. V_{GE}
 $T_J = 25^\circ\text{C}$

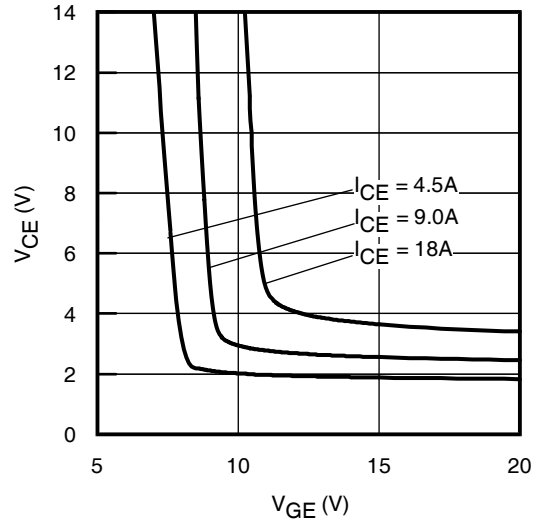

Fig. 10 - Typical V_{CE} vs. V_{GE}
 $T_J = 175^\circ\text{C}$

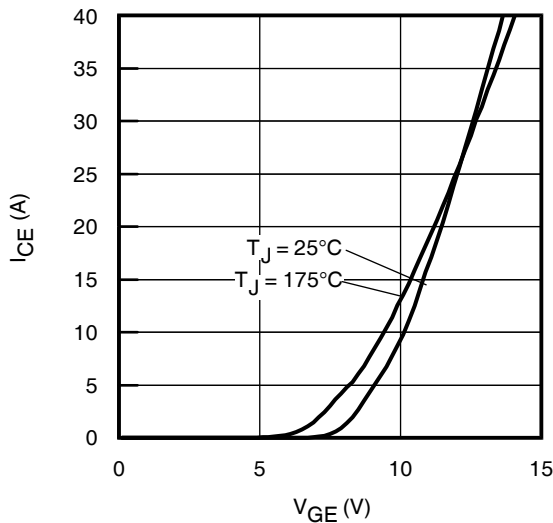

Fig. 11 - Typ. Transfer Characteristics
 $V_{CE} = 50\text{V}$; $t_p = 10\mu\text{s}$

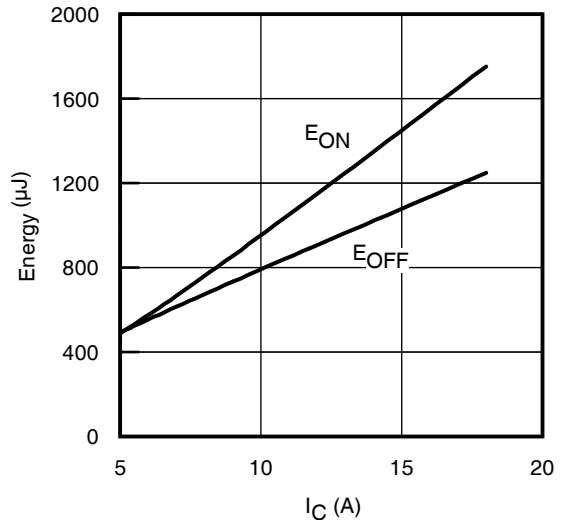

Fig. 12 - Typ. Energy Loss vs. I_C
 $T_J = 175^\circ\text{C}$; $L = 1000\mu\text{H}$; $V_{CE} = 600\text{V}$; $R_G = 22\Omega$; $V_{GE} = 15\text{V}$

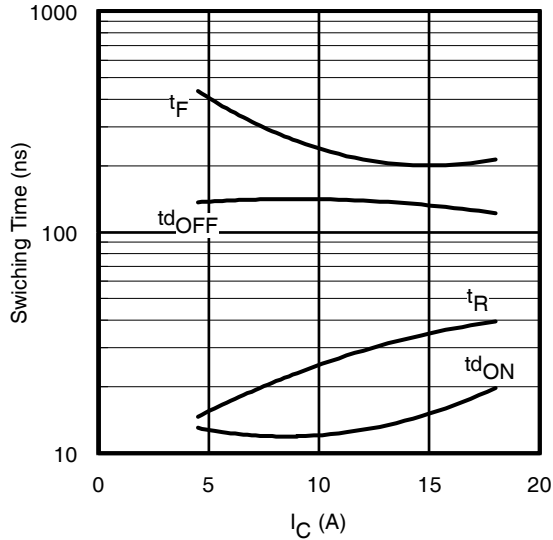

Fig. 13 - Typ. Switching Time vs. I_C

$T_J = 175^\circ\text{C}$; $L = 1000\mu\text{H}$; $V_{CE} = 600\text{V}$; $R_G = 22\Omega$; $V_{GE} = 15\text{V}$

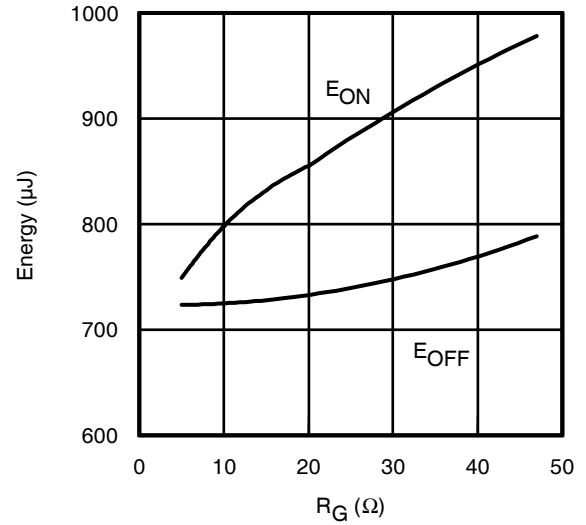

Fig. 14 - Typ. Energy Loss vs. R_G

$T_J = 175^\circ\text{C}$; $L = 1000\mu\text{H}$; $V_{CE} = 600\text{V}$; $I_{CE} = 9.0\text{A}$; $V_{GE} = 15\text{V}$

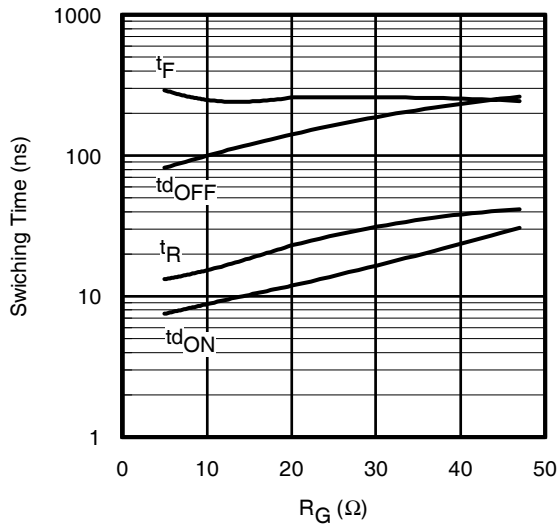

Fig. 15 - Typ. Switching Time vs. R_G

$T_J = 175^\circ\text{C}$; $L = 1000\mu\text{H}$; $V_{CE} = 600\text{V}$; $I_{CE} = 9.0\text{A}$; $V_{GE} = 15\text{V}$

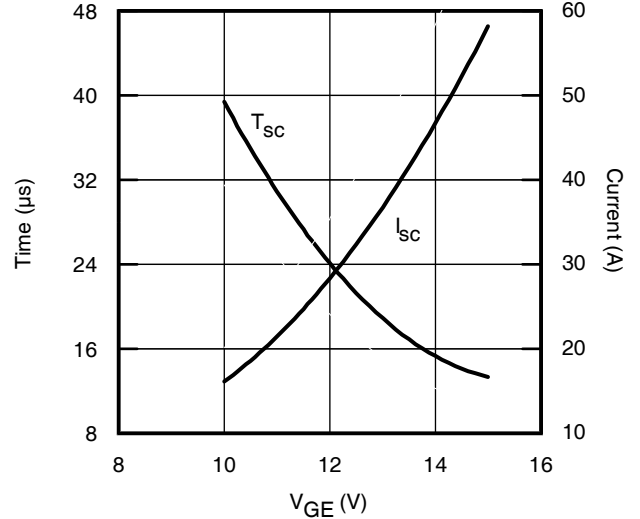

Fig. 16 - V_{GE} vs. Short Circuit Time

$V_{CC} = 600\text{V}$; $T_C = 150^\circ\text{C}$

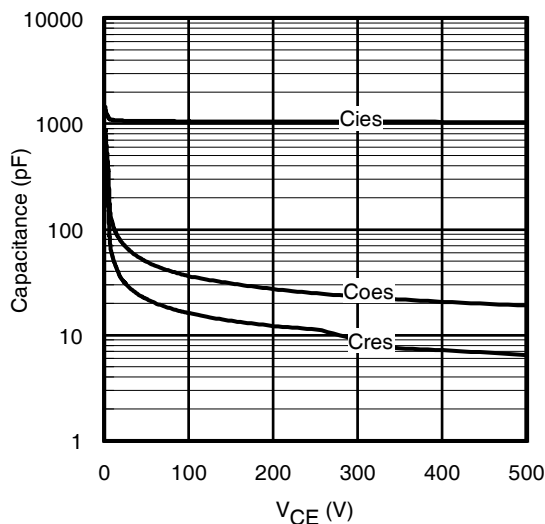

Fig. 17 - Typ. Capacitance vs. V_{CE}

$V_{GE} = 0\text{V}$; $f = 1\text{MHz}$

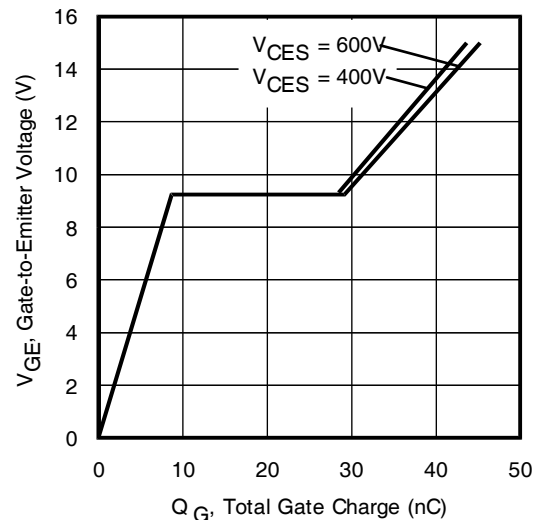

Fig. 18 - Typical Gate Charge vs. V_{GE}

$I_{CE} = 9.0\text{A}$; $L = 1.0\text{mH}$

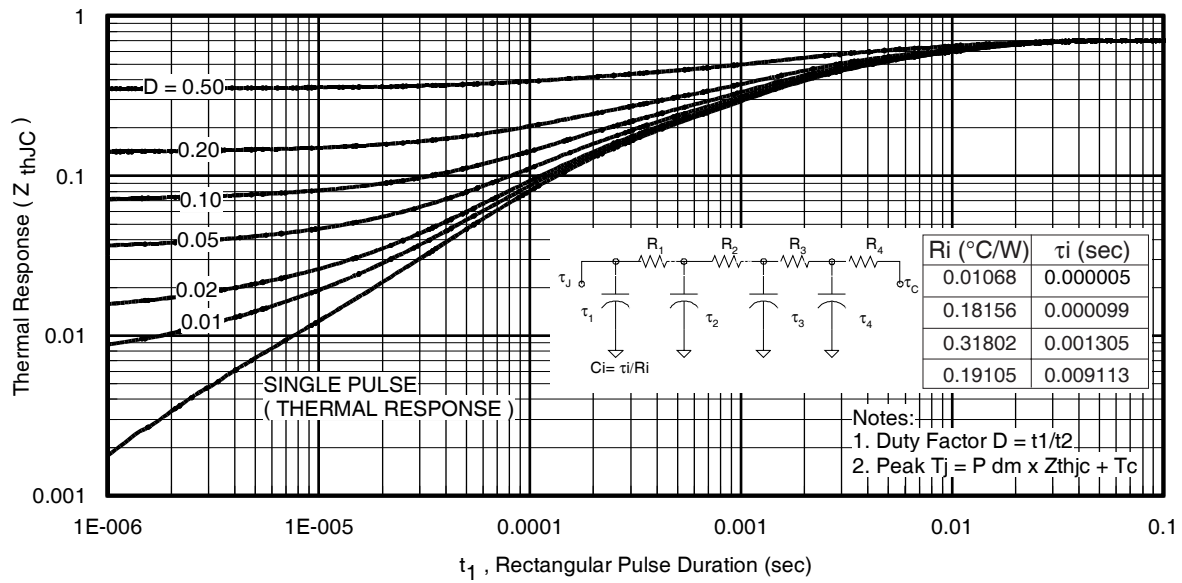

Fig 19. Maximum Transient Thermal Impedance, Junction-to-Case

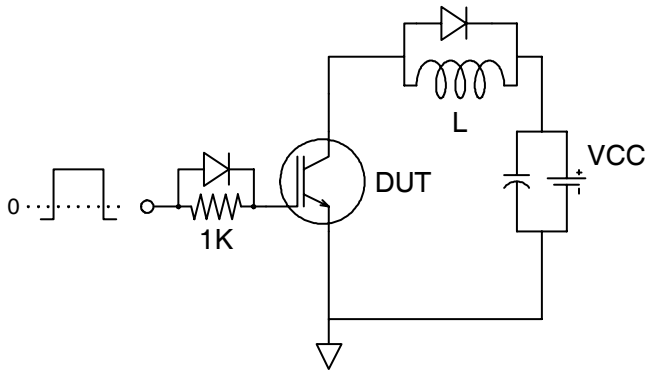

Fig.C.T.1 - Gate Charge Circuit (turn-off)

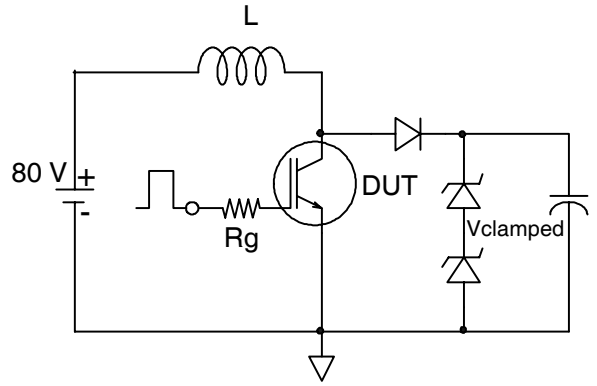

Fig.C.T.2 - RBSOA Circuit

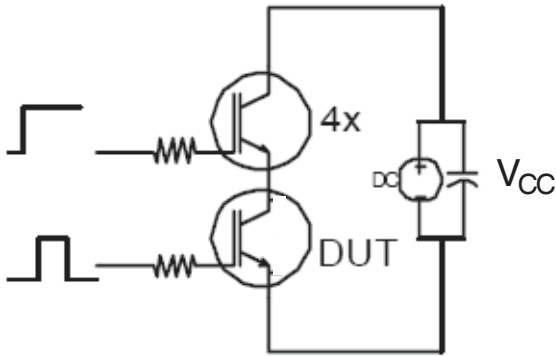

Fig.C.T.3 - S.C. SOA Circuit

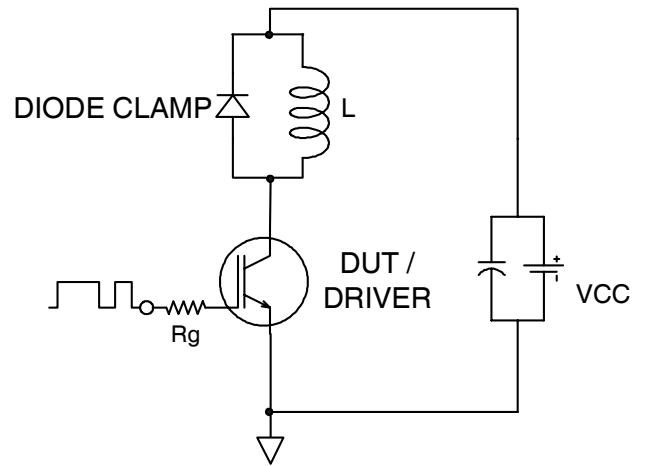

Fig.C.T.4 - Switching Loss Circuit

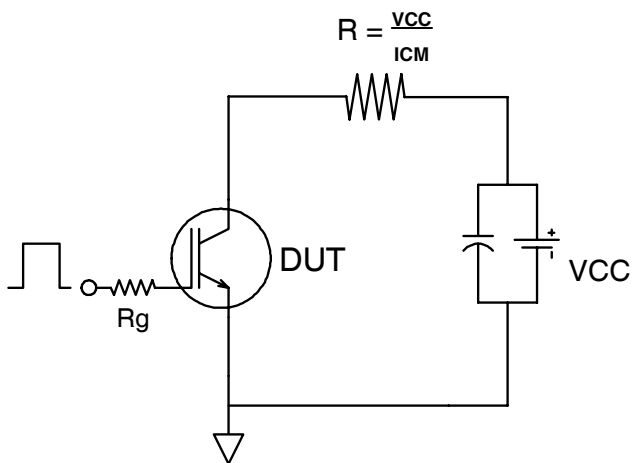

Fig.C.T.5 - Resistive Load Circuit

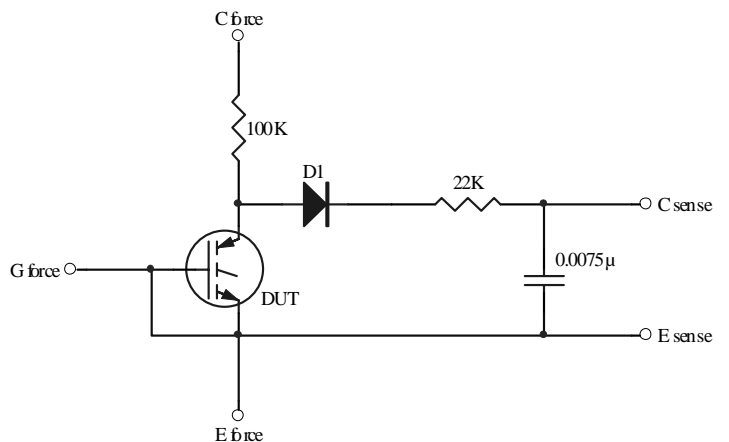

Fig.C.T.6 - BVCES Filter Circuit

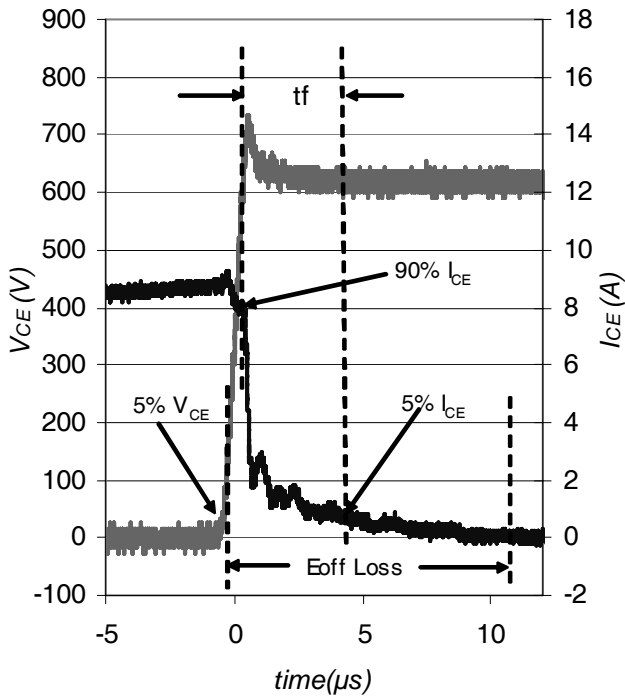

Fig. WF1 - Typ. Turn-off Loss Waveform
@ $T_J = 175^\circ C$ using Fig. CT.4

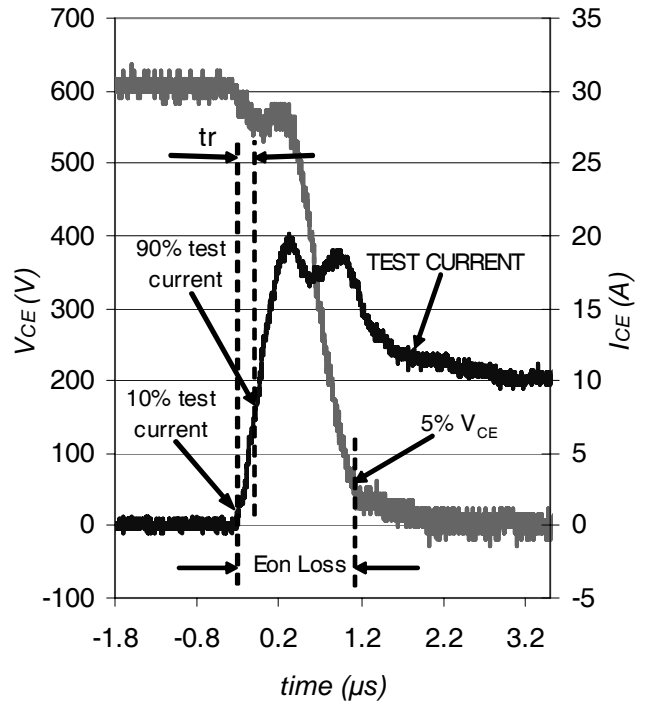

Fig. WF2 - Typ. Turn-on Loss Waveform
@ $T_J = 175^\circ C$ using Fig. CT.4

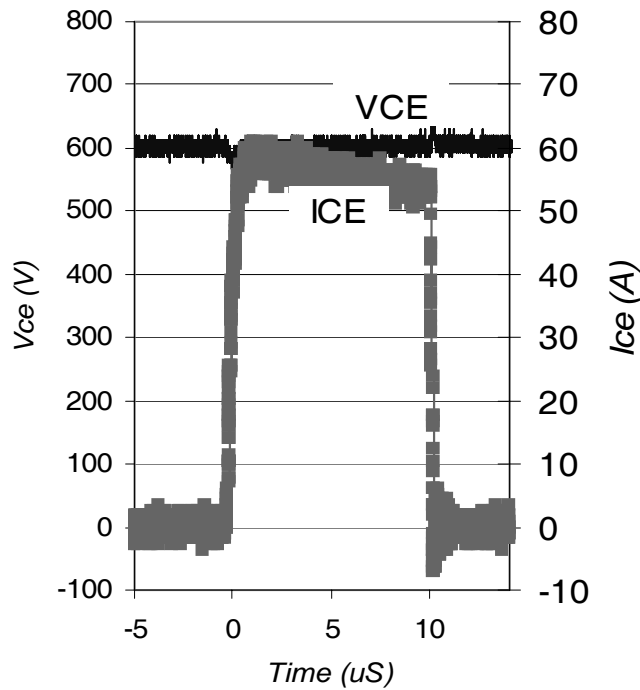
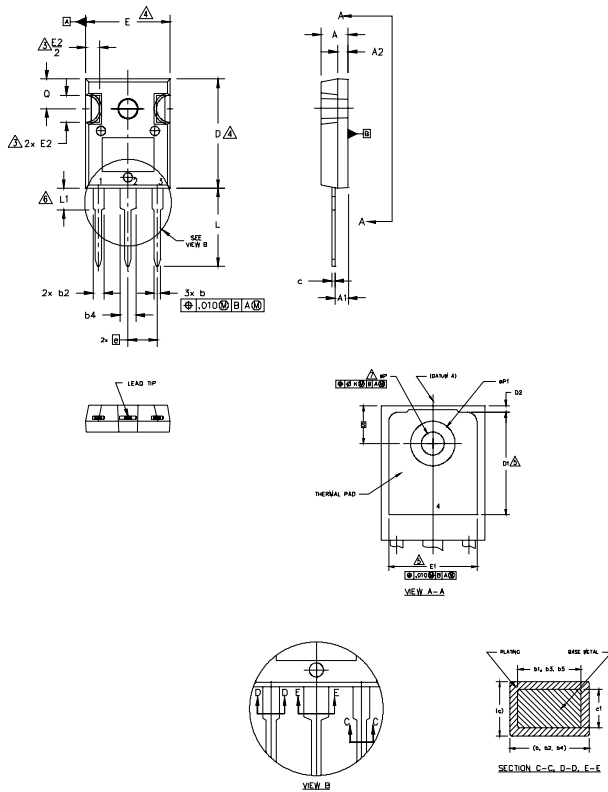

Fig. WF4 - Typ. S.C. Waveform
@ $T_J = 150^\circ C$ using Fig. CT.3

TO-247AC Package Outline

Dimensions are shown in millimeters (inches)



- NOTES:
1. DIMENSIONING AND TOLERANCING AS PER ASME Y14.5M 1994.
 2. DIMENSIONS ARE SHOWN IN INCHES.
 3. CONTOUR OF SLOT OPTIONAL.
 4. DIMENSION D & E DO NOT INCLUDE MOLD FLASH. MOLD FLASH SHALL NOT EXCEED .005" (0.127) PER SIDE. THESE DIMENSIONS ARE MEASURED AT THE OUTERMOST EXTREMES OF THE PLASTIC BODY.
 5. THERMAL PAD CONTOUR OPTIONAL WITHIN DIMENSIONS D1 & E1.
 6. LEAD FINISH UNCONTROLLED IN L1.
 7. ØP TO HAVE A MAXIMUM DRAFT ANGLE OF 1.5 ° TO THE TOP OF THE PART WITH A MAXIMUM HOLE DIAMETER OF .154 INCH.
 8. OUTLINE CONFORMS TO JEDEC OUTLINE TO-247AC .

SYMBOL	DIMENSIONS				NOTES
	INCHES		MILLIMETERS		
	MIN.	MAX.	MIN.	MAX.	
A	.183	.209	4.65	5.31	
A1	.087	.102	2.21	2.59	
A2	.059	.098	1.50	2.49	
b	.039	.055	0.99	1.40	
b1	.039	.053	0.99	1.35	
b2	.065	.094	1.65	2.39	
b3	.065	.092	1.65	2.34	
b4	.102	.135	2.59	3.43	
b5	.102	.133	2.59	3.38	
c	.015	.035	0.38	0.89	
c1	.015	.033	0.38	0.84	
D	.776	.815	19.71	20.70	4
D1	.515	-	13.08	-	5
D2	.020	.053	0.51	1.35	
E	.602	.625	15.29	15.87	4
E1	.530	-	13.46	-	
E2	.178	.216	4.52	5.49	
e	.215 BSC		5.46 BSC		
Øk	.010		0.25		
L	.559	.634	14.20	16.10	
L1	.146	.169	3.71	4.29	
ØP	.140	.144	3.56	3.66	
ØP1	-	.291	-	7.39	
Q	.209	.224	5.31	5.69	
S	.217 BSC		5.51 BSC		

LEAD ASSIGNMENTS

HEXFET

- 1.- GATE
- 2.- DRAIN
- 3.- SOURCE
- 4.- DRAIN

IGBTs, CoPACK

- 1.- GATE
- 2.- COLLECTOR
- 3.- EMITTER
- 4.- COLLECTOR

DIODES

- 1.- ANODE/OPEN
- 2.- CATHODE
- 3.- ANODE

TO-247AC Part Marking Information

EXAMPLE: THIS IS AN IRFPE30
WITH ASSEMBLY
LOT CODE 5657
ASSEMBLED ON WW 35, 2001
IN THE ASSEMBLY LINE "H"

Note: "P" in assembly line position
indicates "Lead-Free"

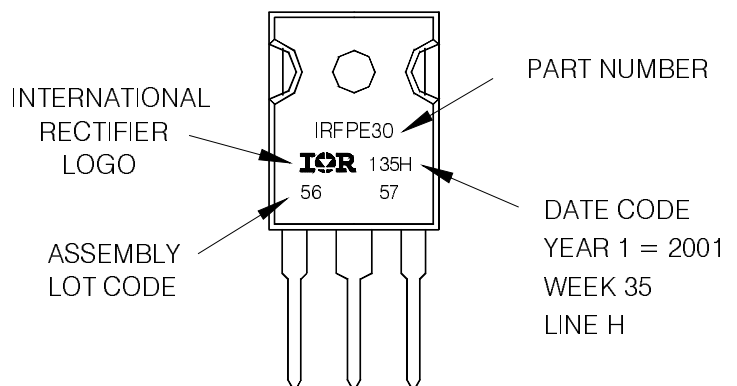

TO-247AC package is not recommended for Surface Mount Application.

Note: For the most current drawing please refer to IR website at <http://www.irf.com/package/>

Data and specifications subject to change without notice.
This product has been designed and qualified for Industrial market.
Qualification Standards can be found on IR's Web site.