

DESIGNED & DIMENSIONED  
IN MILLIMETERS [INCHES]

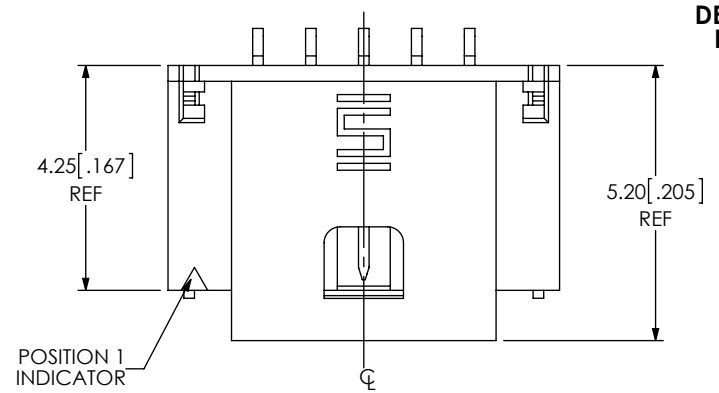

**T1M-XX-X-SH-L-X**

No. OF POSITIONS  
-02 THRU -20

PLATING SPECIFICATION  
-T: MATTE TIN CONTACT AND TAIL  
-F: 3μ" GOLD ON CONTACT,  
MATTE TIN ON TAIL

ROW SPECIFICATION  
-SH: SINGLE ROW, HORIZONTAL

OPTION  
-K: POLYAMIDE FILM  
(SEE FIG 2, SHT 2)

LATCH

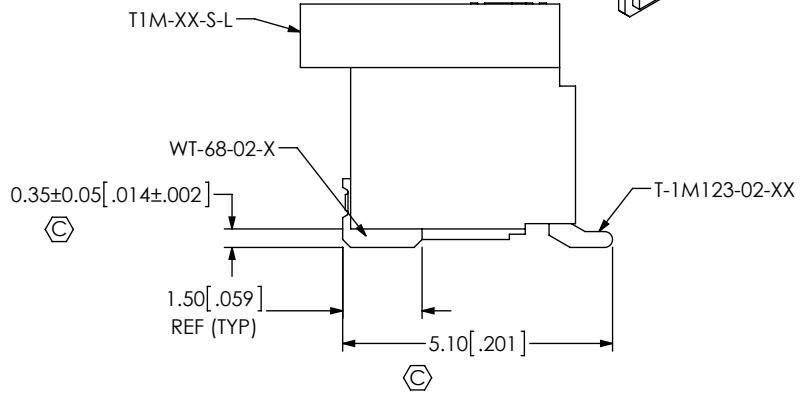
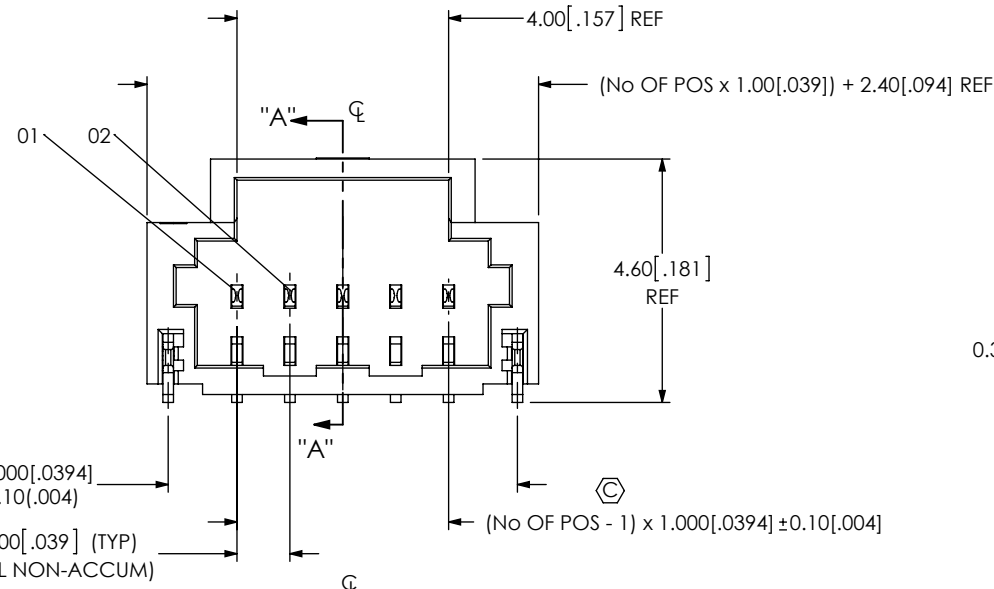
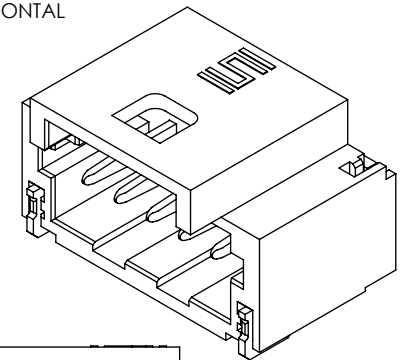
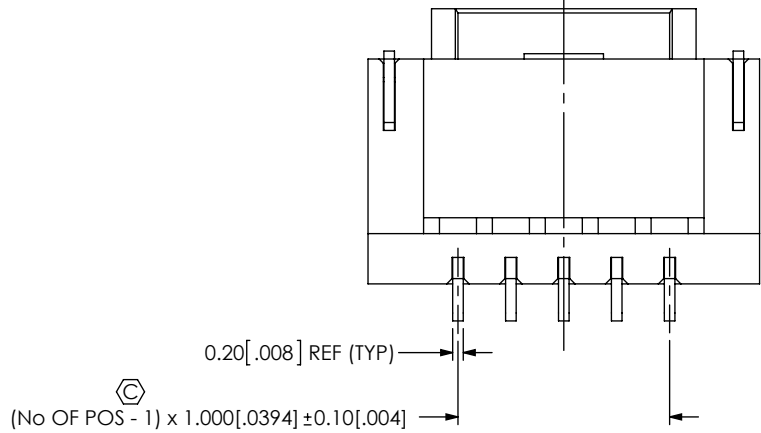

FIG 1  
T1M-05-X-SH-L SHOWN

- NOTES:
- ⊗ REPRESENTS A CRITICAL DIMENSION.
  - MINIMUM PUSHOUT FORCE: 2.22N [.5 LB] FOR SIGNAL AND WELD TAB.
  - PARTS TO BE PACKAGED IN TAPE AND REEL.  
FOR QUANTITIES UP TO 49 PIECES, NO LEADER, TRAILER, OR REEL WILL BE SUPPLIED.  
FOR QUANTITIES OF 50-124 PIECES, NO LEADER OR TRAILER WILL BE SUPPLIED.
  - COPLANARITY MEASUREMENT INCLUDES WT'S.

⊗  
(No OF POS - 1) x 1.00 [.0394]  
+ 2.60 [.1024] ± 0.10 [.004]

1.00 [.039] (TYP)  
(TOL NON-ACCUM)



UNLESS OTHERWISE SPECIFIED,  
DIMENSIONS ARE IN MILLIMETERS.  
TOLERANCES ARE:  
DECIMALS ANGLES  
X.X: ±0.3 [.01] 2°  
X.XX: ±0.13 [.005]  
X.XXX: ±0.051 [.0020]

PROPRIETARY NOTE  
THIS DOCUMENT CONTAINS CONFIDENTIAL AND  
PROPRIETARY INFORMATION AND ALL DESIGN,  
MANUFACTURING, REPRODUCTION, USE, PATENT RIGHTS  
AND SALES RIGHTS ARE EXPRESSLY RESERVED BY SAMTEC,  
INC. THIS DOCUMENT SHALL NOT BE DISCLOSED, IN WHOLE  
OR PART, TO ANY UNAUTHORIZED PERSON OR ENTITY NOR  
REPRODUCED, TRANSFERRED OR INCORPORATED IN ANY  
OTHER PROJECT IN ANY MANNER WITHOUT THE EXPRESS  
WRITTEN CONSENT OF SAMTEC, INC.



520 PARK EAST BLVD., NEW ALBANY, IN 47150  
PHONE: 812-944-6733 FAX: 812-948-5047  
e-Mail: info@SAMTEC.com code 53322

MATERIAL: DO NOT SCALE DRAWING SHEET SCALE: 7:1  
INSULATOR: LCP, UL 94 V-0; COLOR: NATURAL  
TERMINAL: PHOS BRONZE  
WELD TAB: PHOS BRONZE

DESCRIPTION:  
1 MM SINGLE ROW DISCRETE WIRE HEADER  
DWG. NO.  
T1M-XX-X-SH-L-X

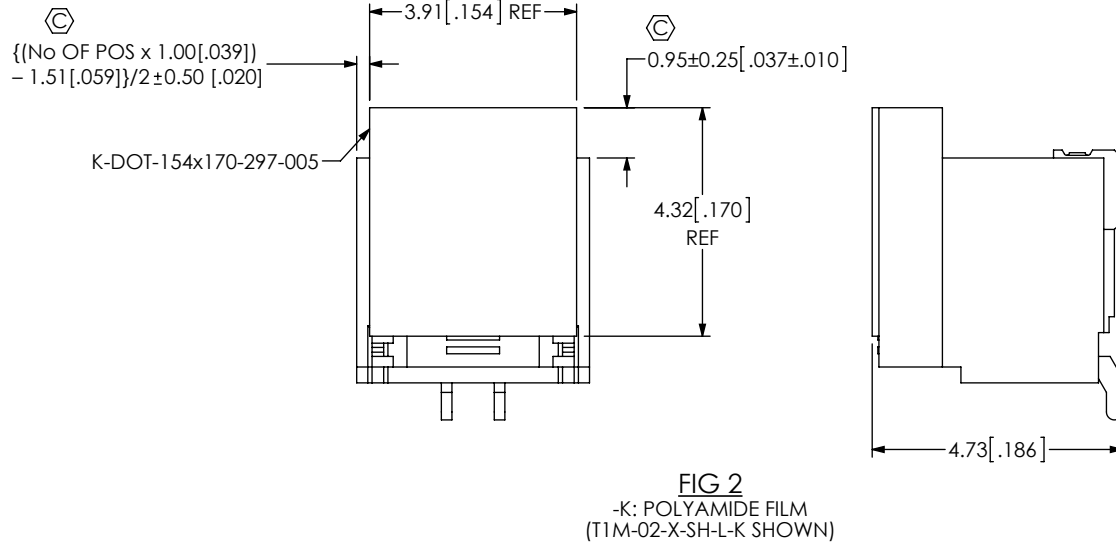
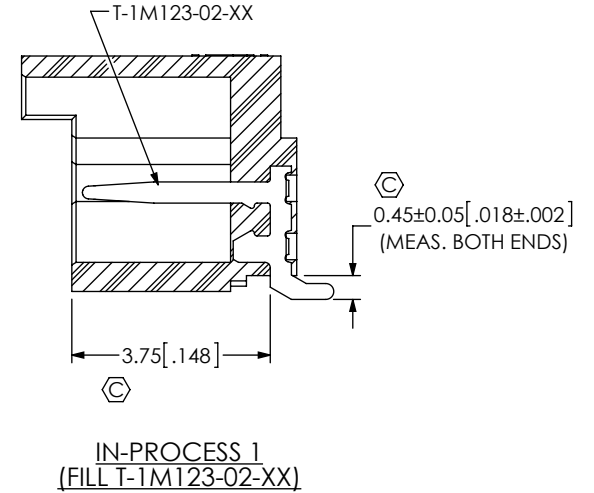
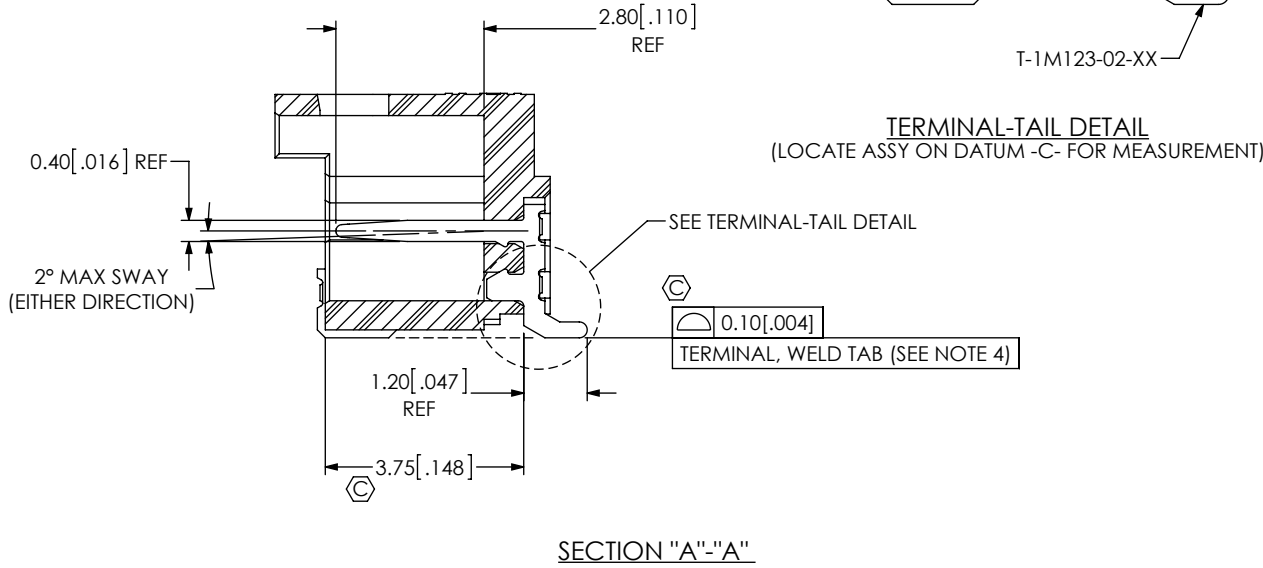

FIG 2  
-K: POLYAMIDE FILM  
(T1M-02-X-SH-L-K SHOWN)

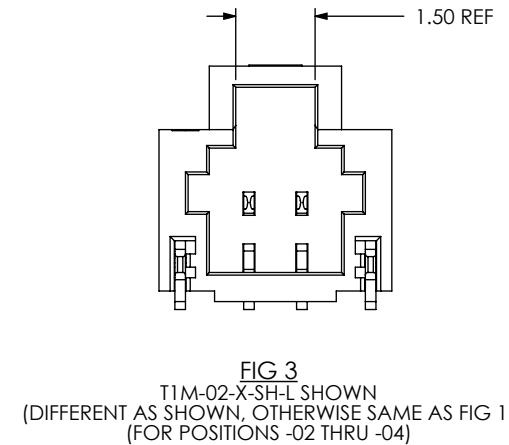

FIG 3  
T1M-02-X-SH-L SHOWN  
(DIFFERENT AS SHOWN, OTHERWISE SAME AS FIG 1)  
(FOR POSITIONS -02 THRU -04)

**PROPRIETARY NOTE**  
THIS DOCUMENT CONTAINS CONFIDENTIAL AND PROPRIETARY INFORMATION AND ALL DESIGN, MANUFACTURING, REPRODUCTION, USE, PATENT RIGHTS AND SALES RIGHTS ARE EXPRESSLY RESERVED BY SAMTEC, INC. THIS DOCUMENT SHALL NOT BE DISCLOSED, IN WHOLE OR PART, TO ANY UNAUTHORIZED PERSON OR ENTITY NOR REPRODUCED, TRANSFERRED OR INCORPORATED IN ANY OTHER PROJECT IN ANY MANNER WITHOUT THE EXPRESS WRITTEN CONSENT OF SAMTEC, INC.

DO NOT SCALE DRAWING  
SHEET SCALE: 7:1



520 PARK EAST BLVD, NEW ALBANY, IN 47150  
PHONE: 812-944-6733 FAX: 812-948-5047  
e-Mail info@SAMTEC.com code 55322

DESCRIPTION:  
1 MM SINGLE ROW DISCRETE WIRE HEADER

DWG. NO.  
T1M-XX-X-SH-L-X

BY: ROY LUO 08/22/2014 SHEET 2 OF 2