

CODE NO.	CONTACT	A	B	C	D	E	F	G	H
CL683-0247-0-57	20	10	6.7	5.6	4.5	9.8	8.2	10.4	7.6
—	26	11.5	8.2	7.1	6	11.3	9.7	11.9	9.1
—	30	12.5	9.2	8.1	7	12.3	10.7	12.9	10.1
—	40	15	11.7	10.6	9.5	14.8	13.2	15.4	12.6
—	50	17.5	14.2	13.1	12	17.3	15.7	17.9	15.1
—	60	20	16.7	15.6	14.5	19.8	18.2	20.4	17.6
—	70	22.5	19.2	18.1	17	22.3	20.7	22.9	20.1
CL683-0188-2-57	80	25	21.7	20.6	19.5	24.8	23.2	25.4	22.6

NOTES 1 : LEAD CO-PLANARITY INCLUDE REINFORCED METAL FITTINGS SHALL BE 0.1mm MAX.  
 2 IF THE RESIST PROCESSING HAS NOT MADE, IT HAS POSSIBILITY THAT THE TERMINAL TOUCHES WITH AREA. PLEASE BE NOTED THIS POINT.

MATED HIGHT (h)		(mm)	
HEADER NO.	RECEPTACLE NO.	DF17#(3.0)-*DS-0.5V(57)	DF17#(4.0)-*DS-0.5V(57)
DF17B(2.5)-*DP-0.5V(57)		5.5	6.5

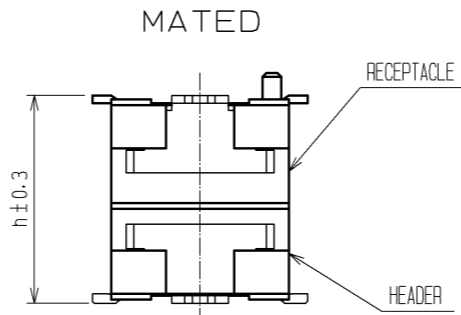

7	PS	CLEAR (REINFORCEMENT COLLAR)
6	PS	BLACK (PLASTIC REEL)
5	POLYESTER	CLEAR (COVER TAPE)
4	PS	CLEAR (EMBOSSED CARRIER TAPE)
3	PHOSPHER BRONZE	TIN PLATED 1μm min UNDER PLATING : NICKEL 1μm min

NO.	MATERIAL	FINISH . REMARKS	NO.	MATERIAL	FINISH . REMARKS
2	POLYAMIDE (PA6T)	WHITE BEIGE . UL94V-0	1	PHOSPHER BRONZE	CONTACT AREA : GOLD PLATED 0.1μm min LEAD AREA : TIN PLATED 1μm min UNDER PLATING : NICKEL 1μm min

UNITS		SCALE	COUNT	DESCRIPTION OF REVISIONS	DESIGNED	CHECKED	DATE
mm		5 : 1	△				

APPROVED : KH. IKEDA	11.12.19	DRAWING NO.	EDC3-163276-77
CHECKED : TS. MIYAZAKI	11.12.19	PART NO.	DF17B(2.5)-*DP-0.5V(57)
DESIGNED : YH. MICHIDA	11.12.17	CODE NO.	CL683
DRAWN : MS. SATO	11.12.17		

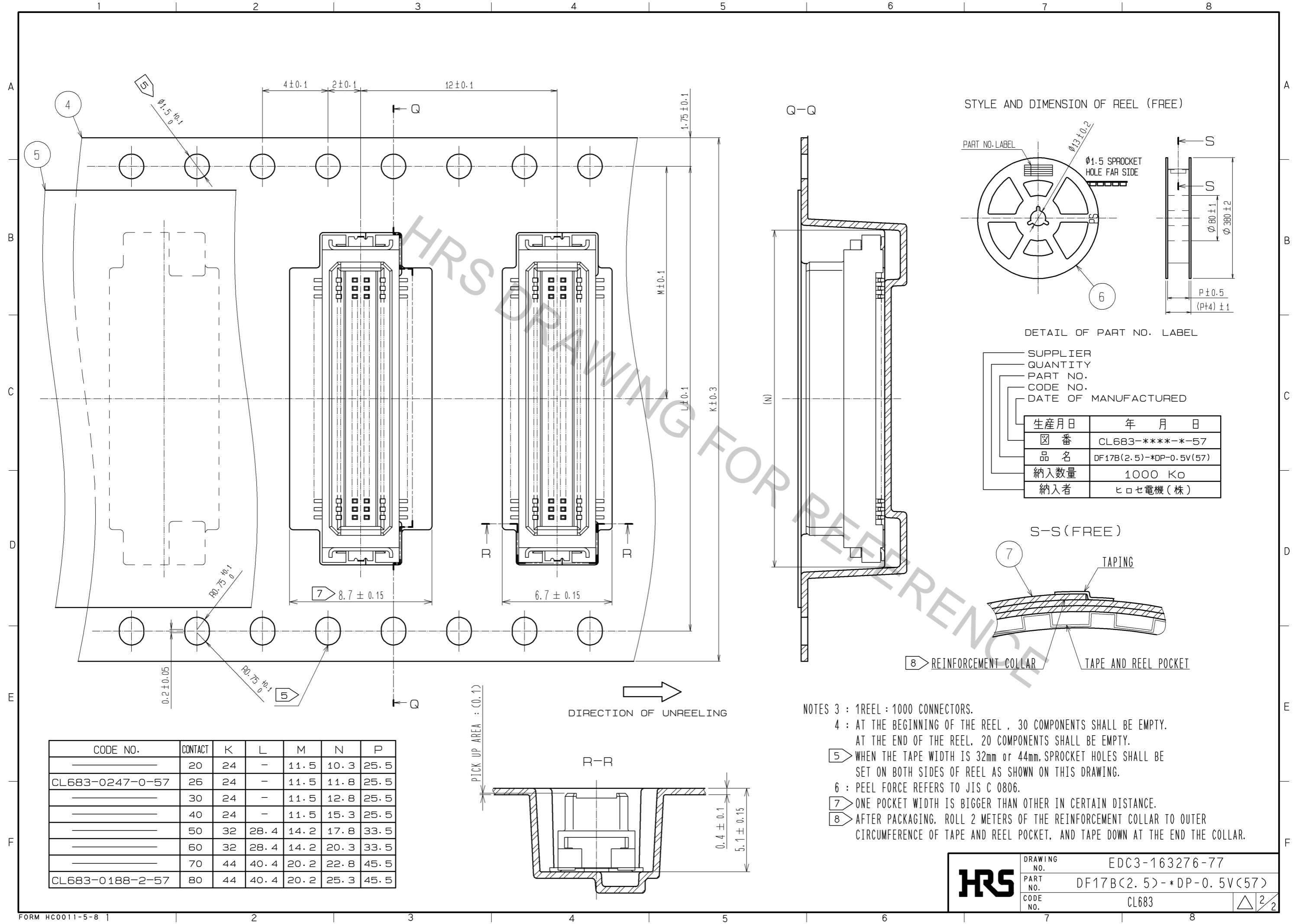

STYLE AND DIMENSION OF REEL (FREE)

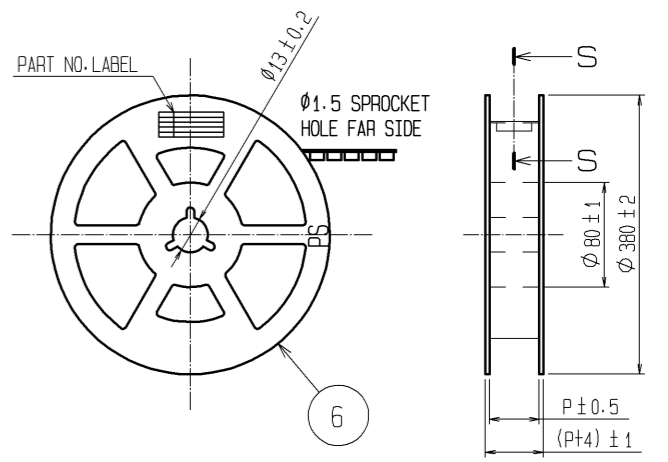

DETAIL OF PART NO. LABEL

SUPPLIER  
QUANTITY  
PART NO.  
CODE NO.  
DATE OF MANUFACTURED

生産月日	年 月 日
☑ 番	CL683-****-*57
品名	DF17B(2.5)-*DP-0.5V(57)
納入数量	1000 KO
納入者	ヒロセ電機(株)

S-S (FREE)

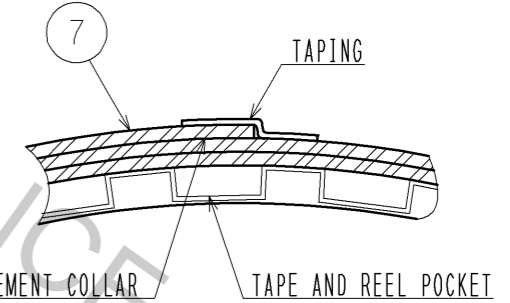

CODE NO.	CONTACT	K	L	M	N	P
_____	20	24	-	11.5	10.3	25.5
CL683-0247-0-57	26	24	-	11.5	11.8	25.5
_____	30	24	-	11.5	12.8	25.5
_____	40	24	-	11.5	15.3	25.5
_____	50	32	28.4	14.2	17.8	33.5
_____	60	32	28.4	14.2	20.3	33.5
_____	70	44	40.4	20.2	22.8	45.5
CL683-0188-2-57	80	44	40.4	20.2	25.3	45.5

- NOTES 3 : 1REEL : 1000 CONNECTORS.  
 4 : AT THE BEGINNING OF THE REEL , 30 COMPONENTS SHALL BE EMPTY.  
 AT THE END OF THE REEL, 20 COMPONENTS SHALL BE EMPTY.  
 5 WHEN THE TAPE WIDTH IS 32mm or 44mm, SPROCKET HOLES SHALL BE SET ON BOTH SIDES OF REEL AS SHOWN ON THIS DRAWING.  
 6 : PEEL FORCE REFERS TO JIS C 0806.  
 7 ONE POCKET WIDTH IS BIGGER THAN OTHER IN CERTAIN DISTANCE.  
 8 AFTER PACKAGING, ROLL 2 METERS OF THE REINFORCEMENT COLLAR TO OUTER CIRCUMFERENCE OF TAPE AND REEL POCKET, AND TAPE DOWN AT THE END THE COLLAR.

<b>HRS</b>	DRAWING NO.	EDC3-163276-77
	PART NO.	DF17B(2.5)-*DP-0.5V(57)
	CODE NO.	CL683
		△ 2/2