

DO NOT SCALE FROM THIS PRINT

DESIGNED & DIMENSIONED IN MILLIMETERS [INCHES]

PATENT PENDING

T1M-XX-XX-DH

No OF POSITIONS (PER ROW) -02 THRU -10
 **-11 THRU **-20
 TAIL OPTION -DH: HORIZONTAL

PLATING SPECIFICATION
 -T: MATTE TIN CONTACT AND TAIL
 -GF: 3μ" GOLD CONTACT AND TAIL

(* = NOT RELEASED FOR PRODUCTION)

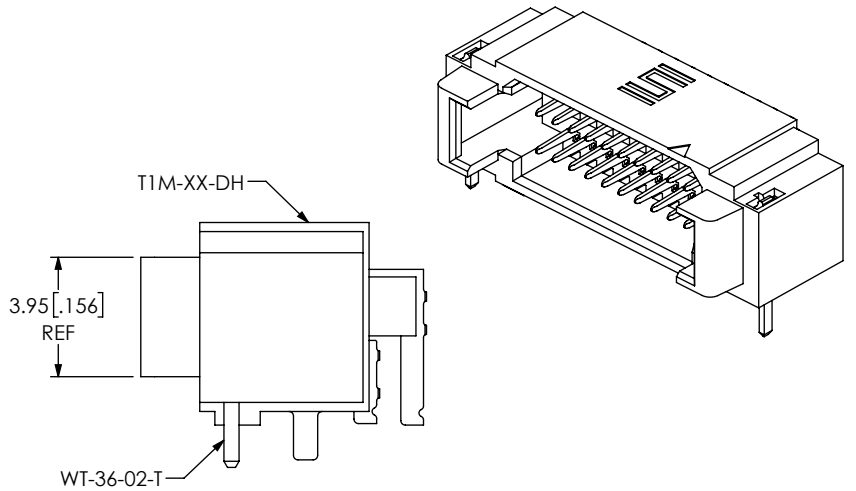
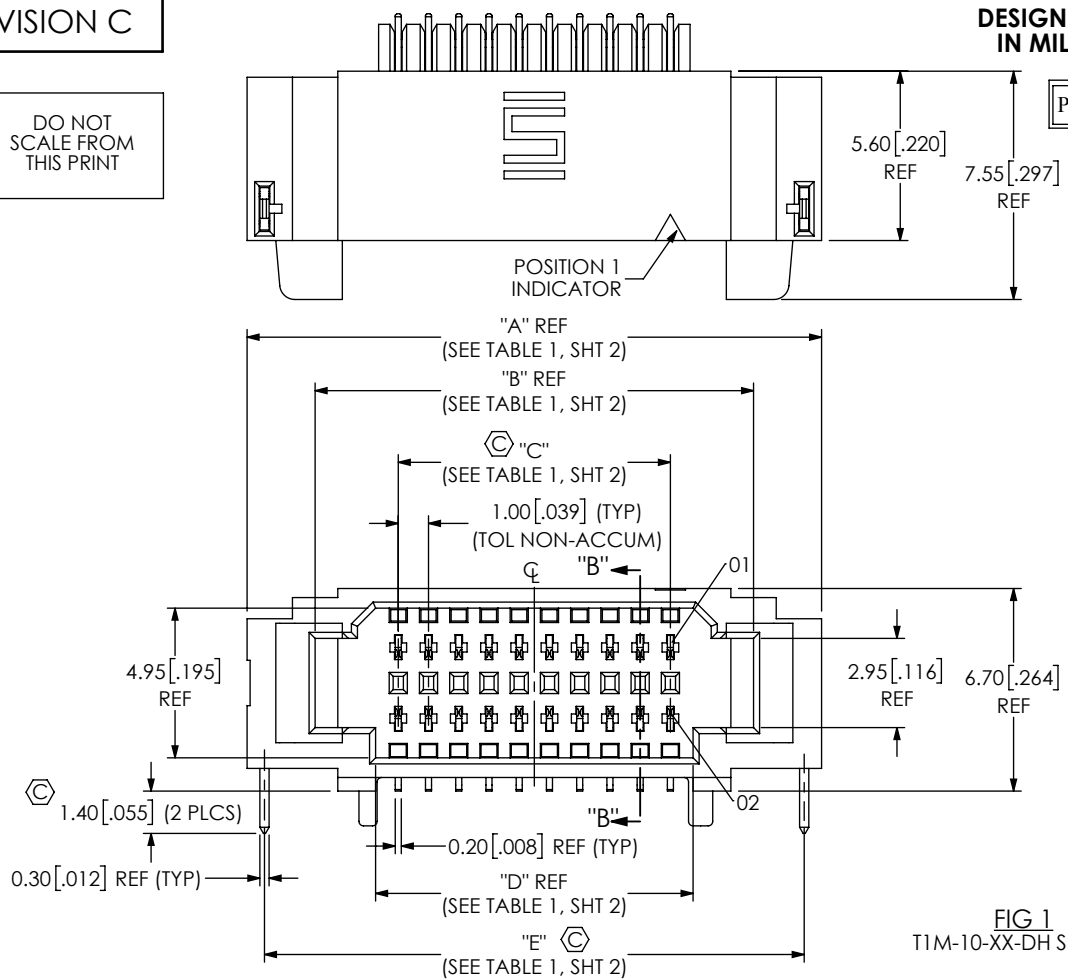
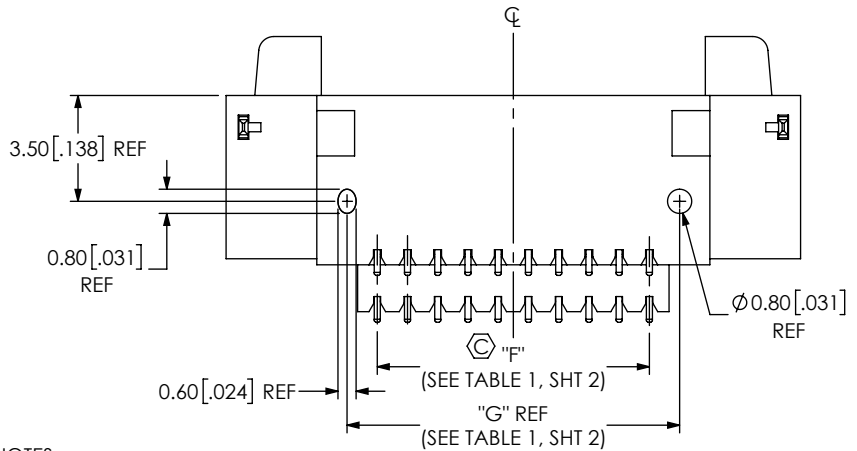

FIG 1
 T1M-10-XX-DH SHOWN



- NOTES:
1. Ⓢ REPRESENTS A CRITICAL DIMENSION.
 2. MINIMUM PUSHOUT FORCE: SIGNAL: 2.22N [.5 LB], WELD TAB: 4.90N [1 LB].
 3. PARTS TO BE PACKAGED IN TAPE AND REEL.
 FOR QUANTITIES UP TO 49 PIECES, NO LEADER, TRAILER, OR REEL WILL BE SUPPLIED.
 FOR QUANTITIES OF 50-124 PIECES, NO LEADER OR TRAILER WILL BE SUPPLIED.

UNLESS OTHERWISE SPECIFIED, DIMENSIONS ARE IN MILLIMETERS. TOLERANCES ARE:
 DECIMALS ANGLES
 X.X: ±0.3 [.01] 2°
 X.XX: ±0.13 [.005]
 X.XXX: ±0.051 [.0020]

PROPRIETARY NOTE
 THIS DOCUMENT CONTAINS CONFIDENTIAL AND PROPRIETARY INFORMATION AND ALL DESIGN, MANUFACTURING, REPRODUCTION, USE, PATENT RIGHTS AND SALES RIGHTS ARE EXPRESSLY RESERVED BY SAMTEC, INC. THIS DOCUMENT SHALL NOT BE DISCLOSED, IN WHOLE OR PART, TO ANY UNAUTHORIZED PERSON OR ENTITY NOR REPRODUCED, TRANSFERRED OR INCORPORATED IN ANY OTHER PROJECT IN ANY MANNER WITHOUT THE EXPRESS WRITTEN CONSENT OF SAMTEC, INC.

MATERIAL: DO NOT SCALE DRAWING SHEET SCALE: 4:1
 INSULATOR: LCP UL 94-V0; COLOR: NATURAL
 TERMINAL: PHOS BRONZE
 WELD TAB: PHOS BRONZE

samtec	
520 PARK EAST BLVD, NEW ALBANY, IN 47150 PHONE: 812-944-6733 FAX: 812-948-5047 e-Mail: info@SAMTEC.com code 53322	
DESCRIPTION: 1 MM DOUBLE ROW DISCRETE WIRE HEADER	
DWG. NO. T1M-XX-XX-DH	
BY: ROY LUO 06/22/2013	SHEET 1 OF 3

TABLE 1

No OF POS	"A"	"B"	"C"	"D"	"E"	"F"	"G"
-02	11.00 [0.433]	6.50 [0.256]	1.00 [0.039]	2.50 [0.098]	9.850 [0.3878]	1.000 [0.0394]	3.00 [0.118]
-03	12.00 [0.472]	7.50 [0.295]	2.00 [0.079]	3.50 [0.138]	10.850 [0.4272]	2.000 [0.0787]	4.00 [0.157]
-04	13.00 [0.512]	8.50 [0.335]	3.00 [0.118]	4.50 [0.177]	11.850 [0.4665]	3.000 [0.1181]	5.00 [0.197]
-05	14.00 [0.551]	9.50 [0.374]	4.00 [0.157]	5.50 [0.217]	12.850 [0.5059]	4.000 [0.1575]	6.00 [0.236]
-06	15.00 [0.591]	10.50 [0.413]	5.00 [0.197]	6.50 [0.256]	13.850 [0.5453]	5.000 [0.1969]	7.00 [0.276]
-07	16.00 [0.630]	11.50 [0.453]	6.00 [0.236]	7.50 [0.295]	14.850 [0.5846]	6.000 [0.2362]	8.00 [0.315]
-08	17.00 [0.669]	12.50 [0.492]	7.00 [0.276]	8.50 [0.335]	15.850 [0.6240]	7.000 [0.2756]	9.00 [0.354]
-09	18.00 [0.709]	13.50 [0.531]	8.00 [0.315]	9.50 [0.374]	16.850 [0.6634]	8.000 [0.3150]	10.00 [0.394]
-10	19.00 [0.748]	14.50 [0.571]	9.00 [0.354]	10.50 [0.413]	17.850 [0.7028]	9.000 [0.3543]	11.00 [0.433]
** -11	20.00 [0.787]	15.50 [0.610]	10.00 [0.394]	11.50 [0.453]	18.850 [0.7421]	10.000 [0.3937]	12.00 [0.472]
** -12	21.00 [0.827]	16.50 [0.650]	11.00 [0.433]	12.50 [0.492]	19.850 [0.7815]	11.000 [0.4331]	13.00 [0.512]
** -13	22.00 [0.866]	17.50 [0.689]	12.00 [0.472]	13.50 [0.531]	20.850 [0.8209]	12.000 [0.4724]	14.00 [0.551]
** -14	23.00 [0.906]	18.50 [0.728]	13.00 [0.512]	14.50 [0.571]	21.850 [0.8602]	13.000 [0.5118]	15.00 [0.591]
** -15	24.00 [0.945]	19.50 [0.768]	14.00 [0.551]	15.50 [0.610]	22.850 [0.8996]	14.000 [0.5512]	16.00 [0.630]
** -16	25.00 [0.984]	20.50 [0.807]	15.00 [0.591]	16.50 [0.650]	23.850 [0.9390]	15.000 [0.5906]	17.00 [0.669]
** -17	26.00 [1.024]	21.50 [0.846]	16.00 [0.630]	17.50 [0.689]	24.850 [0.9783]	16.000 [0.6299]	18.00 [0.709]
** -18	27.00 [1.063]	22.50 [0.886]	17.00 [0.669]	18.50 [0.728]	25.850 [1.0177]	17.000 [0.6693]	19.00 [0.748]
** -19	28.00 [1.102]	23.50 [0.925]	18.00 [0.709]	19.50 [0.768]	26.850 [1.0571]	18.000 [0.7087]	20.00 [0.787]
** -20	29.00 [1.142]	24.50 [0.965]	19.00 [0.748]	20.50 [0.807]	27.850 [1.0965]	19.000 [0.7480]	21.00 [0.827]

(* = NOT RELEASED FOR PRODUCTION)

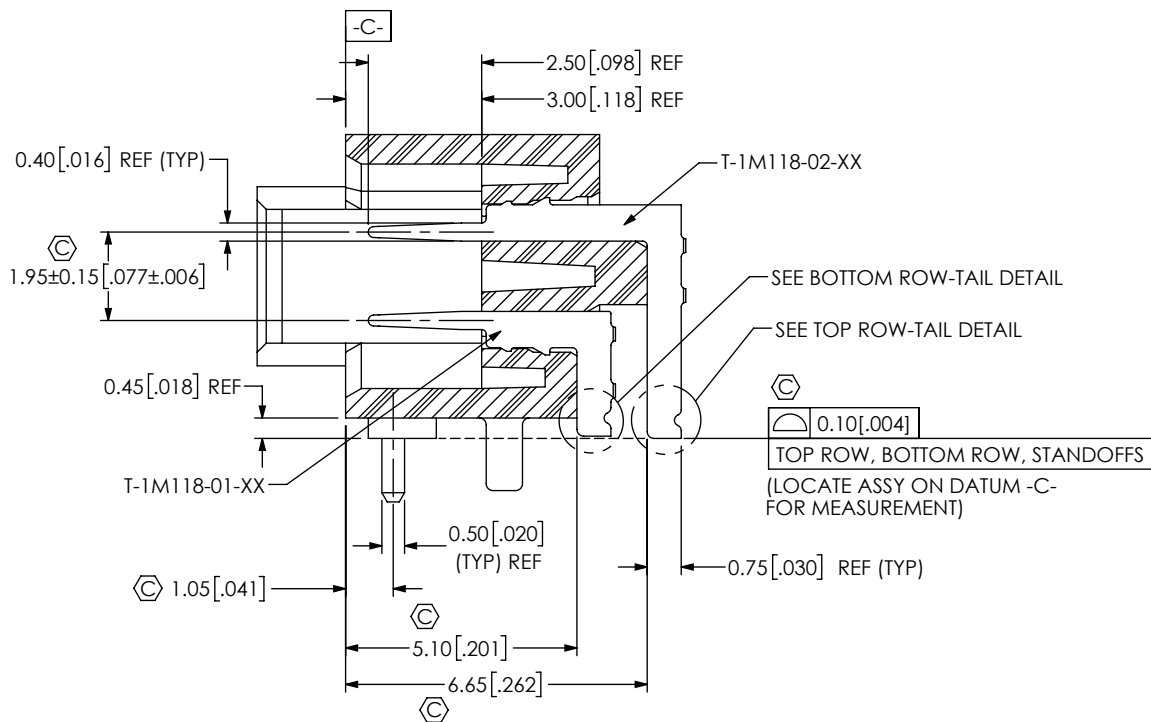

SECTION "B"-"B"
SCALE 6 : 1

F:\DWG\MISC\MKTG\T1M-XX-XX-DH-MKT.SLDDRW

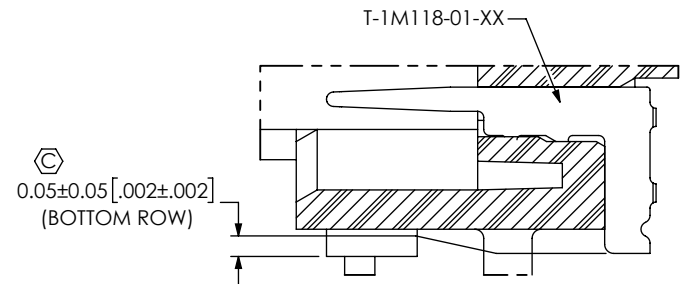

BOTTOM ROW-TAIL DETAIL
(LOCATE ASSY ON DATUM -C- FOR MEASUREMENT)

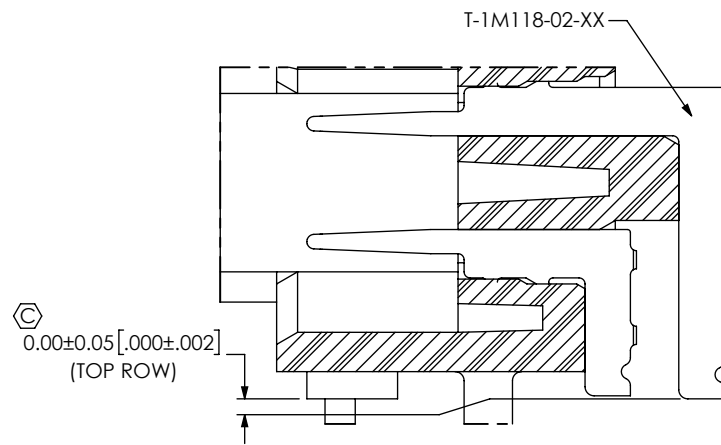

TOP ROW-TAIL DETAIL
(LOCATE ASSY ON DATUM -C- FOR MEASUREMENT)

PROPRIETARY NOTE
THIS DOCUMENT CONTAINS CONFIDENTIAL AND PROPRIETARY INFORMATION AND ALL DESIGN, MANUFACTURING, REPRODUCTION, USE, PATENT RIGHTS AND SALES RIGHTS ARE EXPRESSLY RESERVED BY SAMTEC, INC. THIS DOCUMENT SHALL NOT BE DISCLOSED, IN WHOLE OR PART, TO ANY UNAUTHORIZED PERSON OR ENTITY NOR REPRODUCED, TRANSFERRED OR INCORPORATED IN ANY OTHER PROJECT IN ANY MANNER WITHOUT THE EXPRESS WRITTEN CONSENT OF SAMTEC, INC.



520 PARK EAST BLVD, NEW ALBANY, IN 47150
PHONE: 812-944-6733 FAX: 812-948-5047
e-Mail info@SAMTEC.com code 55322

DO NOT SCALE DRAWING

SHEET SCALE: 6:1

DESCRIPTION:
1 MM DOUBLE ROW DISCRETE WIRE HEADER

DWG. NO. T1M-XX-XX-DH

BY: ROY LUO 06/22/2013 SHEET 2 OF 3

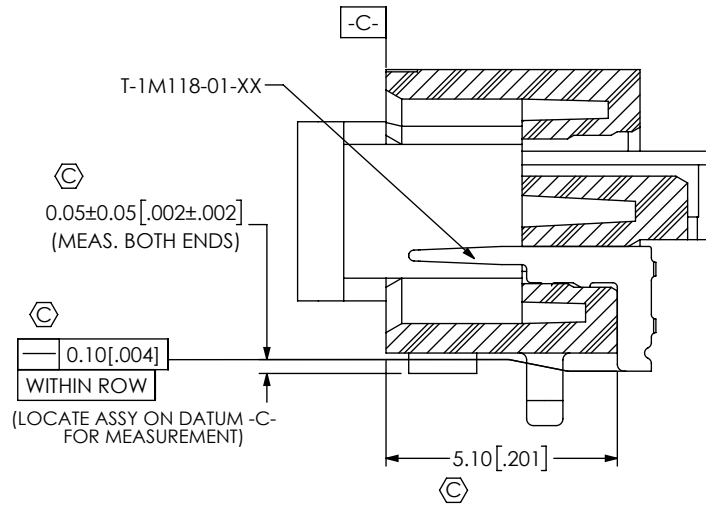

IN-PROCESS 1
(FILL BOTTOM ROW)

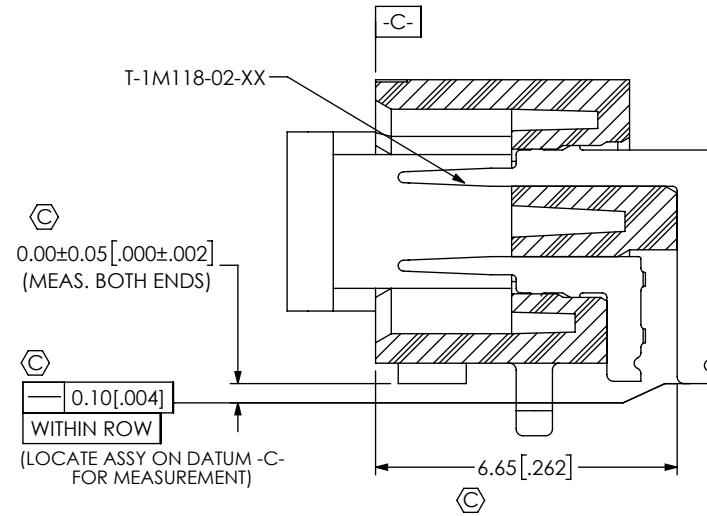

IN-PROCESS 2
(FILL TOP ROW)

PROPRIETARY NOTE
 THIS DOCUMENT CONTAINS CONFIDENTIAL AND PROPRIETARY INFORMATION AND ALL DESIGN, MANUFACTURING, REPRODUCTION, USE, PATENT RIGHTS AND SALES RIGHTS ARE EXPRESSLY RESERVED BY SAMTEC, INC. THIS DOCUMENT SHALL NOT BE DISCLOSED, IN WHOLE OR PART, TO ANY UNAUTHORIZED PERSON OR ENTITY NOR REPRODUCED, TRANSFERRED OR INCORPORATED IN ANY OTHER PROJECT IN ANY MANNER WITHOUT THE EXPRESS WRITTEN CONSENT OF SAMTEC, INC.



520 PARK EAST BLVD, NEW ALBANY, IN 47150
 PHONE: 812-944-6733 FAX: 812-948-5047
 e-Mail: info@SAMTEC.com code 55322

DO NOT SCALE DRAWING

SHEET SCALE: 6:1

DESCRIPTION:
 1 MM DOUBLE ROW DISCRETE WIRE HEADER

DWG. NO.
 T1M-XX-XX-DH

BY: ROY LUO 06/22/2013 SHEET 3 OF 3