

NOTES:

1. MATERIALS AND FINISHES:
 BODY - BRASS, NICKEL PLATING.
 CONTACT - BERYLLIUM COPPER, SILVER PLATING.
 INSULATOR - PTFE, NATURAL
2. ELECTRICAL:
 A. IMPEDANCE: 50 OHM
 B. FREQUENCY RANGE: DC - 4 GHz
 C. DIELECTRIC WITHSTANDING VOLTAGE: 5000 VRMS. MIN.
3. MECHANICAL:
 A. TEMPERATURE RANGE: -65°C - +165°C
4. PACKAGING:
 A. HEX NUT IS PACKAGED LOOSE.
 B. QUANTITY: SINGLE PACK
 C. MARKING: BAG TO BE MARKED
 "AMPHENOL, 82-6317, AND DATE CODE"

THIRD ANGLE PROJ.

REVISIONS

REV	DESCRIPTION	DATE	ECO	APPR
A	RELEASE TO MFG.	4-Dec-02	44297	CPM
B	UPDATED ORIENTATION OF CONTACT	9-Oct-08	47118	NMV
C	TRANSFER TO ARFA	15-Dec-08	--	

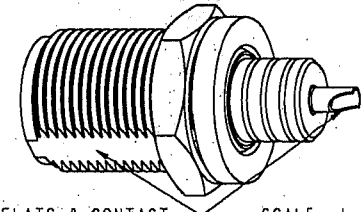
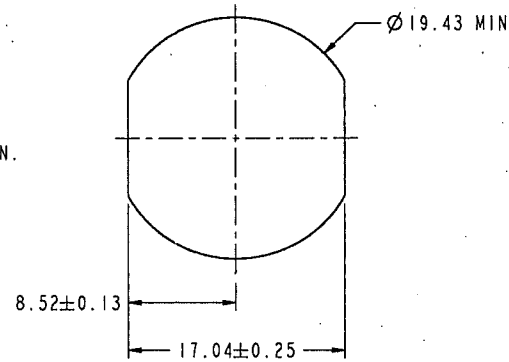

ACROSS FLATS & CONTACT
 MUST BE ORIENTED WITHIN ±2° WITH
 RESPECT TO EACH OTHER AS SHOWN

SCALE 1.500

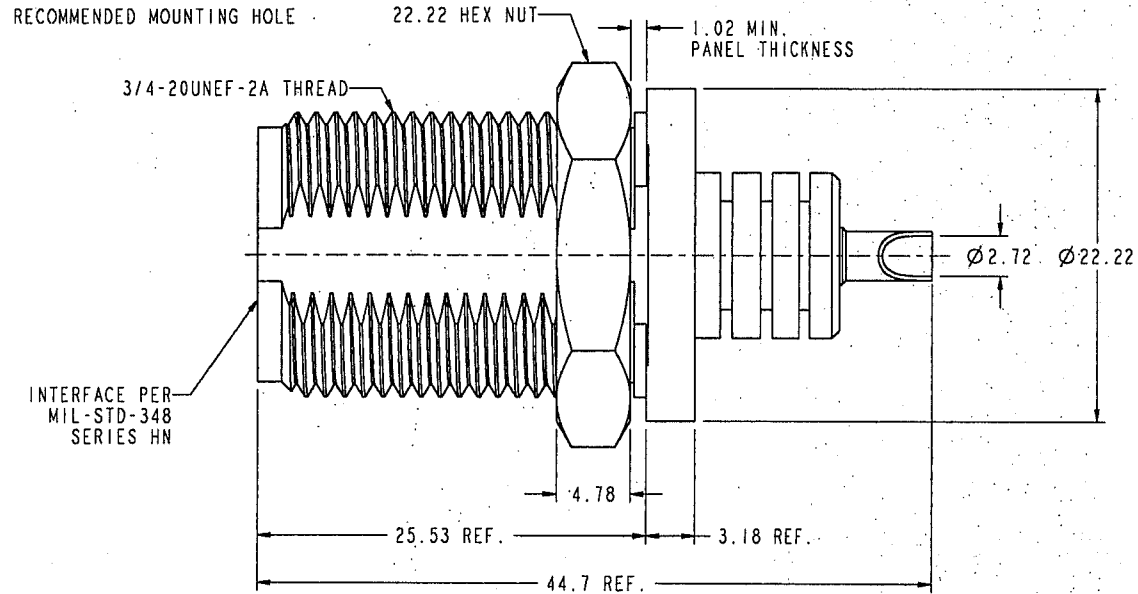
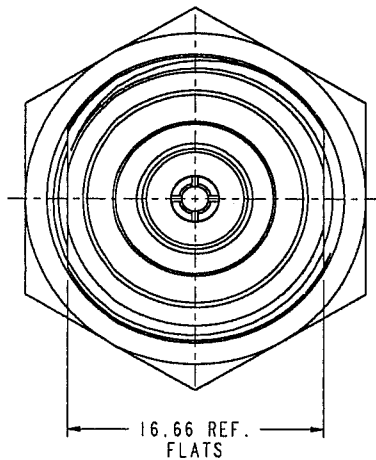

CUSTOMER OUTLINE DRAWING
 ALL OTHER SHEETS ARE FOR INTERNAL USE ONLY

UNLESS OTHERWISE SPECIFIED, DIMENSIONS ARE IN METRIC AND TOLERANCES ARE:
 0.5 - 6mm ±0.1mm
 6 - 30mm ±0.2mm
 30 - 120mm ±0.3mm
 ANGLES ±1°

NOTICE - These drawings, specifications, or other data (1) are, and remain the property of Amphenol Corp. (2) must be returned upon request; and (3) are confidential and not to be disclosed to any person other than those to whom they are given by Amphenol Corp. The furnishing of these drawings, specifications, or other data by Amphenol Corp. or to any other person for any purpose is not to be regarded by implication or otherwise in any manner licensing, granting rights to permitting such holder or any other person to manufacture, use or sell any product, process or design, patented or otherwise, that may in any way be related to or disclosed by said drawings, specifications, or other data.

MATERIAL

DRAWN
 C. McGRTH
 DATE
 22-Nov-02
 ENGINEER
 MIKE HOYACK
 DATE
 28-Jun-02

TITLE
 HN BULKHEAD
 RECEPTACLE

Amphenol RF
 Danbury CT USA, Tainan, Taiwan, Shenzhen, China
 www.amphenolrf.com

REFERENCE
 EAR# 663
 GEN# ASSYF3_HN
 611X-4083-110

APPROVED
 O. BARTHELMES
 DATE
 4-Dec-02
 CAD FILE
 1:/HN/82-6317

SCALE: 3.0:1.0 SHEET 2 OF 2
 DWG SIZE B CODE ID 74868 REV C

DRAWING NO. 82-6317
 ITEM NO. 82-6317
 PART NO. 82-6317