

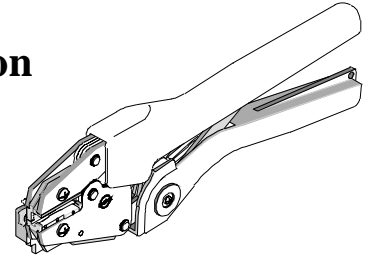

Hand Crimp Tool Operating Instruction And Specifications Sheet

Order No. 64001-0300
Eng. No. RHT 1993
(Replaces 19285-0006)



FEATURES

- A full cycle ratcheting hand tool ensures complete crimps
- Long handles for comfortable crimping with reduced crimping force
- A precision user-friendly terminal locator wire stop holds terminals in the proper crimping position for each of the three nests
- 3-nested tool eliminates the need for additional tools

SCOPE

InsulKrimp™ Terminals and Splices 10 - 22 AWG, (Rings, Spades, Hooks, Block Spades and Flanged Spades).

Testing

Mechanical

The tensile test, or pull test, is a means of evaluating the mechanical properties of the crimped connections. The following charts show the UL specifications for various wire sizes. The tensile strength is shown in pounds and indicates the minimum acceptable force to break or separate the terminal from the conductor.

Wire Size (AWG)	*UL - 486 A	*UL - 486 C
22	8	8
20	13	10
18	20	10
16	30	15
14	50	25
12	70	35
10	80	40

*UL - 486 A - Terminals (Copper conductors only)

*UL - 486 C - Butt Splices

The following is a partial list of the product part numbers and their specifications that this tool is designed to run. We will be adding to this list and an up to date copy is available on www.molex.com

Wire Size: 18 - 22 AWG 0.80 - 0.35mm ²					
Terminal No.	Terminal Eng No. (REF)	Wire Strip Length		Insul. Dia. Max.	
		In.	mm	In.	mm
19034-0001	A-769	.310	7.94	.145	3.68
19034-0002	A-259X	.310	7.94	.145	3.68
19034-0005	A-269X	.310	7.94	.145	3.68
19070-0001	AA-2111-02X	.234	5.95	.145	3.68
19070-0003	AA-2111-04X	.234	5.95	.145	3.68
19070-0005	AA-220-02X	.230	5.95	.145	3.68
19070-0007	AA-220-04X	.230	5.95	.145	3.68

Wire Size: 18 - 22 AWG 0.80 - 0.35mm ²					
Terminal No.	Terminal	Wire Strip Length		Insul. Dia. Max.	
		In.	mm	In.	mm
19070-0009	AA-220-06X	.230	5.95	.145	3.68
19070-0011	AA-221-06X	.230	5.95	.145	3.68
19070-0013	AA-221-08X	.230	5.95	.145	3.68
19070-0015	AA-221-10X	.230	5.95	.145	3.68
19070-0016	AA-221-10XR90	.234	5.95	.145	3.68
19070-0018	AA-221-10XT45	.234	5.95	.145	3.68
19070-0019	AA-221-209X	.234	5.95	.145	3.68

RHT 1993 Hand Crimp Tool

Wire Size: 18 – 22 AWG 0.80 – 0.35mm ²					
Terminal No.	Terminal Eng No. (REF)	Wire Strip Length		Insul. Dia. Max.	
		In.	mm	In.	mm
19070-0021	AA-222-10X	.230	5.95	.145	3.68
19070-0023	AA-222-14X	.230	5.95	.145	3.68
19070-0026	AA-222-56X	.230	5.95	.145	3.68
19070-0029	AA-226-10X	.234	5.95	.145	3.68
19070-0031	AA-226-14X	.234	5.95	.145	3.68
19070-0033	AA-226-38X	.230	5.95	.145	3.68
19070-0036	AA-226-56X	.234	5.95	.145	3.68
19070-0038	AA-232-04X	.230	5.95	.145	3.68
19070-0040	AA-232-06X	.230	5.95	.145	3.68
19070-0044	AA-232-08X	.230	5.95	.145	3.68
19070-0051	AA-233-10X	.230	5.95	.145	3.68
19070-0094	AA-220-06XR90	.234	5.95	.145	3.68
19071-0001	AA-6111-02X	.234	5.95	.145	3.68
19071-0003	AA-6111-04X	.234	5.95	.145	3.68
19071-0005	AA-620-02X	.234	5.95	.145	3.68
19071-0007	AA-620-04X	.234	5.95	.145	3.68
19071-0009	AA-620-06X	.234	5.95	.145	3.68
19071-0011	AA-621-06X	.234	5.95	.145	3.68
19071-0013	AA-621-08X	.234	5.95	.145	3.68
19071-0015	AA-621-10X	.234	5.95	.145	3.68
19071-0017	AA-622-10X	.234	5.95	.145	3.68
19071-0019	AA-622-14X	.234	5.95	.145	3.68
19071-0021	AA-622-56X	.234	5.95	.145	3.68
19071-0023	AA-626-10X	.234	5.95	.145	3.68
19071-0024	AA-626-14X	.234	5.95	.145	3.68
19071-0026	AA-626-38X	.234	5.95	.145	3.68
19071-0028	AA-626-56X	.234	5.95	.145	3.68
19071-0030	AA-632-04X	.234	5.95	.145	3.68
19071-0032	AA-632-06X	.234	5.95	.145	3.68
19071-0034	AA-632-08X	.234	5.95	.145	3.68
19071-0040	AA-633-10X	.234	5.95	.145	3.68
19080-0001	A-2006-MSX	.310	7.94	.145	3.68
19090-0007	AA-2110-02X	.230	5.95	.145	3.68
19090-0009	AA-2110-04X	.234	5.95	.145	3.68
19090-0011	AA-214-04X	.234	5.95	.145	3.68
19090-0013	AA-214-06X	.230	5.95	.145	3.68
19090-0024	AA-292-06X	.234	5.95	.145	3.68
19090-0026	AA-292-08X	.234	5.95	.145	3.68
19090-0028	AA-292-10X	.234	5.95	.145	3.68
19090-0030	AA-295-06X	.234	5.95	.145	3.68
19090-0032	AA-295-08X	.234	5.95	.145	3.68
19090-0034	AA-295-10X	.234	5.95	.145	3.68
19090-0036	AA-298-04X	.234	5.95	.145	3.68
19090-0038	AA-298-06X	.234	5.95	.145	3.68
19090-0040	AA-298-08X	.234	5.95	.145	3.68
19090-0042	AA-298-10X	.234	5.95	.145	3.68
19092-0001	AA-605-04X	.234	5.95	.145	3.68
19092-0003	AA-605-06X	.234	5.95	.145	3.68
19092-0009	AA-6110-02X	.234	5.95	.145	3.68
19092-0011	AA-6110-04X	.234	5.95	.145	3.68
19092-0013	AA-614-04X	.234	5.95	.145	3.68
19092-0015	AA-614-06X	.234	5.95	.145	3.68
19092-0017	AA-614-08X	.234	5.95	.145	3.68
19092-0019	AA-692-06X	.234	5.95	.145	3.68
19092-0021	AA-692-08X	.234	5.95	.145	3.68
19092-0023	AA-692-10X	.234	5.95	.145	3.68
19092-0025	AA-695-06X	.234	5.95	.145	3.68
19092-0027	AA-695-08X	.234	5.95	.145	3.68
19092-0029	AA-695-10X	.234	5.95	.145	3.68
19092-0031	AA-698-04X	.234	5.95	.145	3.68
19092-0033	AA-698-06X	.234	5.95	.145	3.68
19092-0035	AA-698-08X	.234	5.95	.145	3.68
19092-0037	AA-698-10X	.234	5.95	.145	3.68
19099-0001	AA-2190-06X	.230	5.95	.145	3.68
19099-0003	AA-2191-08X	.230	5.95	.145	3.68
19099-0005	AA-2192-10X	.230	5.95	.145	3.68

Wire Size: 18 – 22 AWG 0.80 – 0.35mm ²					
Terminal No.	Terminal	Wire Strip Length		Insul. Dia. Max.	
		In.	mm	In.	mm
19099-0007	AA-2704-05X	.230	5.95	.145	3.68
19099-0009	AA-2704-06X	.230	5.95	.145	3.68
19099-0011	AA-2705-08X	.234	5.95	.145	3.68
19099-0012	AA-2706-10X	.234	5.95	.145	3.68
19099-0013	AA-2714-08X	.230	5.95	.145	3.68
19099-0015	AA-2715-10X	.230	5.95	.145	3.68
19099-0081	AA-2704-04X	.234	5.95	.145	3.68
19121-0001	AA-2108-02X	.234	5.95	.145	3.68
19121-0002	AA-2108-04X	.230	5.95	.145	3.68
19121-0004	AA-215-04X	.234	5.95	.145	3.68
19121-0005	AA-215-06X	.230	5.95	.145	3.68
19121-0007	AA-215-08X	.230	5.95	.145	3.68
19121-0009	AA-215-10X	.230	5.95	.145	3.68
19121-0011	AA-2461-04X	.234	5.95	.145	3.68
19121-0012	AA-2461-06X	.234	5.95	.145	3.68
19121-0013	AA-2461-08X	.234	5.95	.145	3.68
19121-0014	AA-2461-10X	.234	5.95	.145	3.68
19121-0015	AA-290-06X	.234	5.95	.145	3.68
19121-0016	AA-290-08X	.234	5.95	.145	3.68
19121-0017	AA-290-10X	.234	5.95	.145	3.68
19121-0018	AA-293-06X	.234	5.95	.145	3.68
19121-0019	AA-293-08X	.234	5.95	.145	3.68
19121-0020	AA-293-10X	.234	5.95	.145	3.68
19121-0021	AA-296-04X	.234	5.95	.145	3.68
19121-0022	AA-296-06X	.230	5.95	.145	3.68
19121-0024	AA-296-08X	.234	5.95	.145	3.68
19122-0001	AA-6108-02X	.234	5.95	.145	3.68
19122-0003	AA-6108-04X	.234	5.95	.145	3.68
19122-0005	AA-615-04X	.234	5.95	.145	3.68
19122-0007	AA-615-06X	.234	5.95	.145	3.68
19122-0009	AA-615-08X	.234	5.95	.145	3.68
19122-0011	AA-690-06X	.234	5.95	.145	3.68
19122-0013	AA-690-08X	.234	5.95	.145	3.68
19122-0015	AA-690-10X	.234	5.95	.145	3.68
19122-0017	AA-693-06X	.234	5.95	.145	3.68
19122-0019	AA-693-08X	.234	5.95	.145	3.68
19122-0021	AA-693-10X	.234	5.95	.145	3.68
19122-0023	AA-696-04X	.234	5.95	.145	3.68
19122-0025	AA-696-06X	.234	5.95	.145	3.68
19131-0027	AA-294-10X	.230	5.95	.145	3.68
19131-0028	AA-294-08X	.234	5.95	.145	3.68
19131-0029	AA-294-06X	.234	5.95	.145	3.68
19131-0031	AA-238-06X	.230	5.95	.145	3.68
19131-0033	AA-238-04X	.234	5.95	.145	3.68
19131-0034	AA-234-10X	.230	5.95	.145	3.68
19131-0036	AA-234-08X	.230	5.95	.145	3.68
19131-0038	AA-234-06X	.230	5.95	.145	3.68
19131-0039	AA-234-04X	.234	5.95	.145	3.68
19131-0042	AA-2118-06X	.230	5.95	.145	3.68
19131-0045	AA-2109-04X	.230	5.95	.145	3.68
19131-0047	AA-2109-02X	.230	5.95	.145	3.68
19133-0001	AA-634-04X	.234	5.95	.145	3.68
19133-0002	AA-634-06X	.234	5.95	.145	3.68
19133-0003	AA-634-08X	.234	5.95	.145	3.68
19133-0004	AA-634-10X	.234	5.95	.145	3.68
19144-0001	AA-235-06X	.230	5.95	.145	3.68
19144-0003	AA-235-08X	.230	5.95	.145	3.68
19144-0005	AA-235-10X	.230	5.95	.145	3.68
19144-0007	AA-291-06X	.234	5.95	.145	3.68
19144-0008	AA-291-08X	.234	5.95	.145	3.68
19144-0009	AA-291-10X	.234	5.95	.145	3.68
19144-0010	AA-297-04X	.234	5.95	.145	3.68
19144-0011	AA-297-06X	.234	5.95	.145	3.68
19144-0012	AA-297-08X	.234	5.95	.145	3.68
191450001	AA-6109-02X	.234	5.95	.145	3.68
191450003	AA-6109-04X	.234	5.95	.145	3.68

Wire Size: 18 – 22 AWG 0.80 – 0.35mm ²					
Terminal No.	Terminal Eng No. (REF)	Wire Strip Length		Insul. Dia. Max.	
		In.	mm	In.	mm
191450011	AA-635-06X	.234	5.95	.145	3.68
191450013	AA-635-08X	.234	5.95	.145	3.68
191450015	AA-635-10X	.234	5.95	.145	3.68
191450017	AA-638-04X	.234	5.95	.145	3.68
191450019	AA-638-06X	.234	5.95	.145	3.68
191450022	AA-691-06X	.234	5.95	.145	3.68
191450024	AA-691-08X	.234	5.95	.145	3.68
191450026	AA-691-10X	.234	5.95	.145	3.68
191450028	AA-694-06X	.234	5.95	.145	3.68
191450030	AA-694-08X	.234	5.95	.145	3.68
191450032	AA-694-10X	.234	5.95	.145	3.68
191450034	AA-697-04X	.234	5.95	.145	3.68
191450036	AA-697-06X	.234	5.95	.145	3.68
191450038	AA-697-08X	.234	5.95	.145	3.68
19154-0004	A-245X	.310	7.94	.145	3.68
19154-0011	AS-V-345X	.280	7.15	.145	3.68
191640010	SA-269	.280	7.14		
19179-0002	AA-210-06X	.230	5.95	.145	3.68
19179-0006	AA-210-10X	.230	5.95	.145	3.68
191820001	AA-610-06X	.234	5.95	.145	3.68
191820003	AA-610-08X	.234	5.95	.145	3.68
191820005	AA-610-10X	.234	5.95	.145	3.68
19202-0010	AS-932	.310	7.94		0.00
19202-0011	AS-932-DK	.310	7.94		
19202-0062	A-945	.310	7.94	.145	3.68
19202-0063	A-945-DK	.310	7.94	.145	3.68
19204-0003	A-2XCX	.310	7.94		
19204-0004	A-2YCX	.310	7.94		
19207-0002	AS-N-302	.280	7.15	.120	3.05
19212-0003	WP-2218X	.190	4.76	.145	3.68

Wire Size: 14 – 16 AWG 2.00 – 1.30mm ²					
Terminal No.	Terminal Eng No. (REF)	Wire Strip Length		Insul. Dia. Max.	
		In.	mm	In.	mm
19034-0004	B-789	.250	6.35		0.00
19034-0007	B-279X	.310	7.94	.175	4.45
19070-0059	BB-218-38X	.230	5.95	.175	4.45
19070-0063	BB-218-56X	.230	5.95	.175	4.45
19070-0065	BB-223-02X	.230	5.95	.175	4.45
19070-0067	BB-223-04X	.230	5.95	.175	4.45
19070-0069	BB-223-06X	.230	5.95	.175	4.45
19070-0071	BB-223-08X	.230	5.95	.175	4.45
19070-0073	BB-225-10X	.230	5.95	.175	4.45
19070-0075	BB-225-14X	.230	5.95	.175	4.45
19070-0078	BB-225-56X	.230	5.95	.175	4.45
19070-0083	BB-237-06X	.230	5.95	.175	4.45
19070-0086	BB-237-08X	.230	5.95	.175	4.45
19070-0090	BB-237-10X	.230	5.95	.175	4.45
19070-0099	BB-239-08X	.230	5.95	.175	4.45
19070-0102	BB-239-10X	.230	5.95	.175	4.45
19070-0105	BB-239-10XX	.230	5.95	.175	4.45
19070-0270	BB-237-06XX	.230	5.95	.175	4.45
19070-0271	BB-239-08XX	.230	5.95	.175	4.45
19070-0285	BB-237-08XX		0.00	.175	4.45
19070-0322	BB-237-10XX		0.00	.175	4.45
19080-0003	B-2006-MSX	.310	7.94	.170	4.32
19090-0044	BB-213-04X	.230	5.95	.175	4.45
19090-0046	BB-213-06X	.230	5.95	.175	4.45
19090-0048	BB-213-08X	.230	5.95	.175	4.45
19090-0071	BB-288-06X	.230	5.95	.175	4.45
19090-0075	BB-288-10X	.230	5.95	.175	4.45
19099-0017	BB-2193-06X	.230	5.95	.175	4.45
19099-0019	BB-2194-08X	.230	5.95	.175	4.45
19099-0022	BB-2195-10X	.230	5.95	.175	4.45
19099-0025	BB-2707-05X	.230	5.95	.175	4.45

Wire Size: 14 – 16 AWG 2.00 – 1.30mm ²					
Terminal No.	Terminal	Wire Strip Length		Insul. Dia. Max.	
		In.	mm	In.	mm
19099-0027	BB-2707-06X	.230	5.95	.175	4.45
19099-0032	BB-2716-08X	.230	5.95	.175	4.45
19099-0034	BB-2717-10X	.230	5.95	.175	4.45
19099-0077	BB-2707-06XX	.230	5.95		0.00
19121-0026	BB-216-06X	.230	5.95	.175	4.45
19121-0028	BB-216-08X	.230	5.95	.175	4.45
19121-0030	BB-216-10X	.230	5.95	.175	4.45
19121-0040	BB-283-10X	.230	5.95	.175	4.45
19131-0007	BB-287-08X	.230	5.95	.175	4.45
19131-0014	BB-2781-10X	.230	5.95	.175	4.45
19131-0018	BB-2781-08X	.230	5.95	.175	4.45
19131-0020	BB-2781-06X	.230	5.95	.175	4.45
19131-0023	BB-2471-06X	.230	5.95	.175	4.45
19131-0025	BB-2471-04X	.230	5.95	.175	4.45
19144-0013	BB-207-04X	.230	5.95	.175	4.45
19144-0015	BB-207-06X	.230	5.95	.175	4.45
19144-0018	BB-224-06X	.230	5.95	.175	4.45
19144-0020	BB-224-08X	.230	5.95	.175	4.45
19144-0024	BB-227-08X	.230	5.95	.175	4.45
19144-0026	BB-227-10X	.230	5.95	.175	4.45
19154-0015	B-231X	.230	5.95	.175	4.45
19154-0023	BS-V-331X	.280	7.15		
19179-0008	BB-219-06X	.230	5.95	.175	4.45
19179-0010	BB-219-08X	.230	5.95	.175	4.45
19179-0012	BB-219-10X	.230	5.95	.175	4.45
19202-0018	B-931	.310	7.94		0.00
19202-0019	B-931-DK	.310	7.94		
19202-0026	BS-942	.310	7.94	.199	5.05
19202-0027	BS-942-DK	.310	7.94	.199	5.05
19202-0031	BS-N-331	.280	7.15		
19204-0013	B-2XCX	.310	7.94		
19204-0014	B-2YCX	.310	7.94		
19206-0004	B-204X	.280	7.15	.175	4.45
19207-0004	BS-N-304	.280	7.15	.150	3.81
19127-0005	WP-2614XC	.190	4.76	.175	4.45

Wire Size: 10 – 12 AWG 5.00 – 3.00mm ²					
Terminal No.	Terminal Eng No. (REF)	Wire Strip Length		Insul. Dia. Max.	
		In.	mm	In.	mm
19070-0109	C-201-12X	.380	9.53	.250	6.35
19070-0115	C-201-76X	.380	9.53	.250	6.35
19070-0119	C-228-06X	.380	9.53	.250	6.35
19070-0121	C-228-08X	.380	9.53	.250	6.35
19070-0123	C-228-10X	.380	9.53	.250	6.35
19070-0130	C-230-10X	.380	9.53	.250	6.35
19070-0132	C-230-14X	.380	9.53	.250	6.35
19070-0136	C-230-56X	.380	9.53	.250	6.35
19070-0143	C-236-06X	.380	9.53	.250	6.35
19070-0145	C-236-08X	.380	9.53	.250	6.35
19070-0150	C-240-14X	.380	9.53	.250	6.35
19070-0153	C-240-38X	.380	9.53	.250	6.35
19070-0155	C-240-56X	.380	9.53	.250	6.35
19080-0005	C-2006-MSX	.380	9.53	.250	6.35
19090-0079	C-2106-06X	.380	9.53	.250	6.35
19090-0083	C-212-08X	.380	9.53	.250	6.35
19090-0085	C-212-10X	.380	9.53	.250	6.35
19099-0036	C-2196-06X	.380	9.53	.250	6.35
19099-0038	C-2197-08X	.380	9.53	.250	6.35
19099-0040	C-2198-10X	.380	9.53	.250	6.35
19099-0042	C-2199-14X	.380	9.53	.250	6.35
19099-0044	C-2710-06X	.380	9.53	.250	6.35
19099-0048	C-2718-08X	.380	9.53	.250	6.35
19099-0050	C-2719-10X	.380	9.53	.250	6.35
19121-0045	C-2101-08X	.380	9.53	.250	6.35

Wire Size: 10 – 12 AWG 5.00 – 3.00mm ²					
Terminal No.	Terminal Eng No. (REF)	Wire Strip Length		Insul. Dia. Max.	
		In.	mm	In.	mm
19121-0046	C-2104-06X	.380	5.95	.250	6.35
19121-0047	C-2104-08X	.380	5.95	.250	6.35
19121-0049	C-2104-10X	.380	5.95	.250	6.35
19121-0051	C-217-06X	.380	5.95	.250	6.35
19121-0053	C-217-08X	.380	5.95	.250	6.35
19121-0056	C-217-10X	.380	0.00	.250	6.35
19131-0002	C-2105-10X	.380	5.95	.250	6.35
19131-0004	C-2105-08X	.380	5.95	.250	6.35
19131-0006	C-2105-06X	.380	5.95	.250	6.35
19144-0037	C-241-06X	.380	9.53	.250	6.35
19144-0039	C-241-08X	.380	9.53	.250	6.35
19144-0042	C-241-10X	.380	9.53	.250	6.35
19144-0046	C-268-14X	.380	9.53	.265	6.73
19154-0028	C-246X	.230	5.95	.250	6.35

Wire Size: 10 – 12 AWG 5.00 – 3.00mm ²					
Terminal No.	Terminal	Wire Strip Length		Insul. Dia. Max.	
		In.	mm	In.	mm
19154-0037	CS-V-346X	.280	7.15	.250	6.35
19179-0014	C-211-06X	.380	9.53	.250	6.35
19179-0019	C-211-10X	.380	7.15	.250	6.35
19202-0045	CS-952	.360	9.13	.250	6.35
19202-0046	CS-952-DK	.360	9.13	.250	6.35
19202-0049	CS-N-346	.360	9.13		
19202-0052	CS-N-346X	.360	9.13		
19204-0025	C-2XCX	.380	9.53		
19204-0026	C-2YCX	.380	9.53	.210	5.33
19206-0008	C-203X	.280	5.95		0.00
19207-0005	CS-N-303	.280	7.14	.260	6.60
19212-0001	WP-2210X	.280	7.15	.250	6.35

OPERATION

Open the tool by first closing the jaws sufficiently for the ratchet mechanism to release.

Crimping Terminals

1. Push up on the locator blade and position the terminal with the barrel facing up into the proper color-coded nest with front edge of the barrel against the locator. See Figure 1. Release the locator blade to hold the terminal in position.
2. Partially close the tool to hold the terminal in place. See Figure 2.
3. Insert the properly stripped wire into the terminal barrel. See Figure 2 and 3. The wires end should butt against the wire stop position of the locator. Cycle the tool.

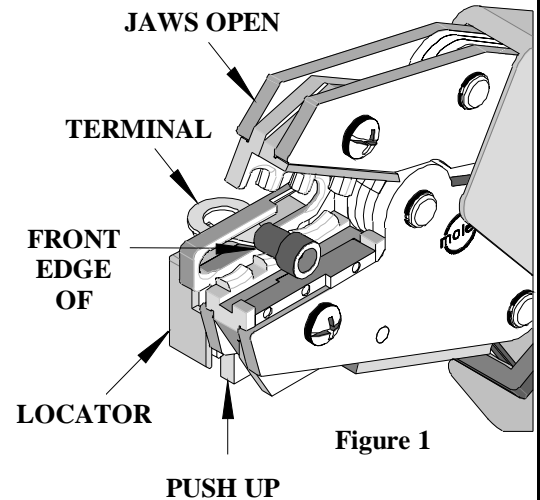

Figure 1

Note: The tamper proof ratchet action will not release the tool until it has been fully closed.

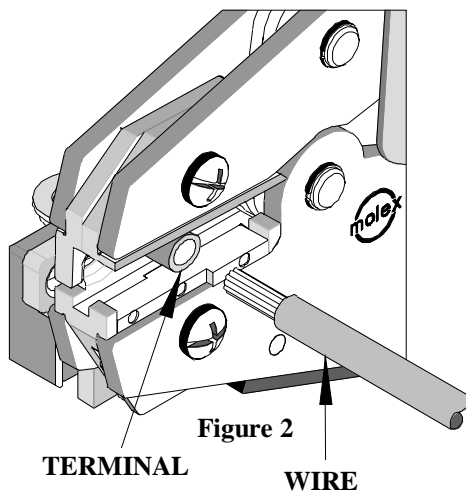
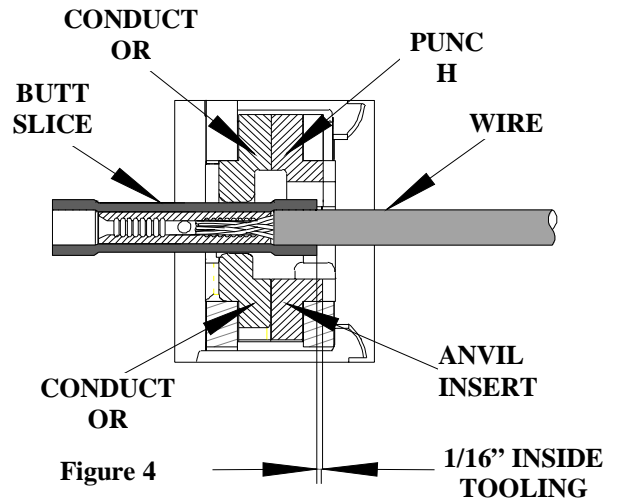
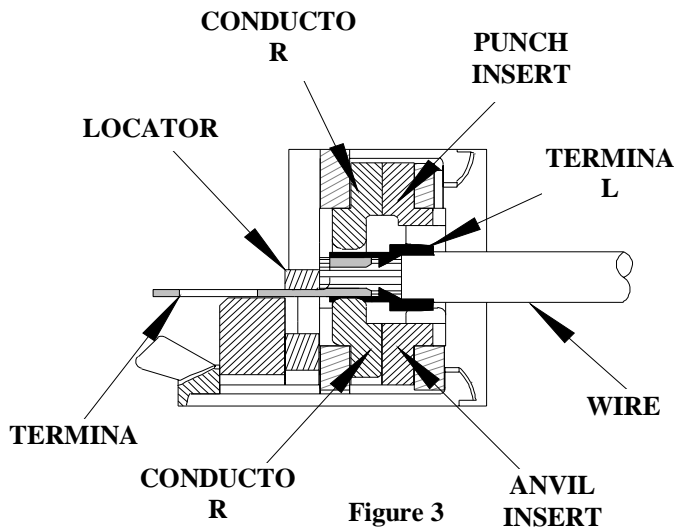

Figure 2

4. Lift the locator blade or wire stop and remove the crimped terminal. Inspect for proper crimp location. Locator is adjustable up and down to keep terminals straight after crimping.
5. When crimping butt splices, the locator must be removed and the splice visually aligned with the tooling 1/16" inside the tooling inserts. See Figure 4.

Note: Whenever crimping without the locator, make sure the seam of the terminal is oriented up or down in the tool if using unbrazed product, as this will provide higher pull force values.



Maintenance

It is recommended that each operator of the tool be made aware of, and responsible for, the following maintenance steps:

1. Remove dust, moisture and other contaminants with a clean brush, or soft, lint-free cloth.
2. Do not use any abrasive materials that could damage the tool.
3. Make certain all pins; pivot points and bearing surfaces are protected with a thin coat of high quality machine oil. Do not oil excessively. The 64001-0300 (RHT-1993) was engineered for durability, but like any fine piece of equipment it needs cleaning and lubrication for a maximum service life of trouble-free crimping. A light oil, such as 30 weight automotive oil used at the oil points shown in Figure 5, every 5,000 crimps or 3 months will significantly enhance the tool life and ensure a stable calibration.
4. When tool is not in use, keep the handles closed to prevent objects from becoming lodged in the crimping dies, and store the tool in a clean, dry area.

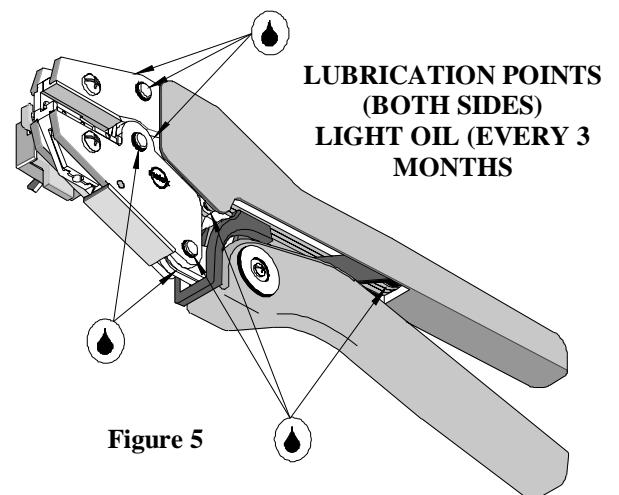

Miscrimps or Jams

Should this tool ever become stuck or jammed in a partially closed position, **Do Not** force the handles open or closed. The tool will open easily by lifting the ratchet release lever (See Figure 6).

How To Adjust Tool Preload (See Figure 6)

Over the life of the tool, it may be necessary to adjust tool handle preload force. Listed below are the steps required to adjust the crimping force of the hand tool to obtain proper crimp conditions:

1. Remove the screw and plastic cover washer. Note the setting wheel position.
2. Lift the setting wheel off the axle. Turn the eccentric axle with a screwdriver.
3. Turning the eccentric axle counter-clockwise (CCW) will increase handle force.
4. Replace the setting wheel to the axle, aligning the nearest notch in the setting wheel to the dowel pin.
5. Replace the plastic cover washer and screw.
6. Check the crimp specifications after tool handle preload force is adjusted.

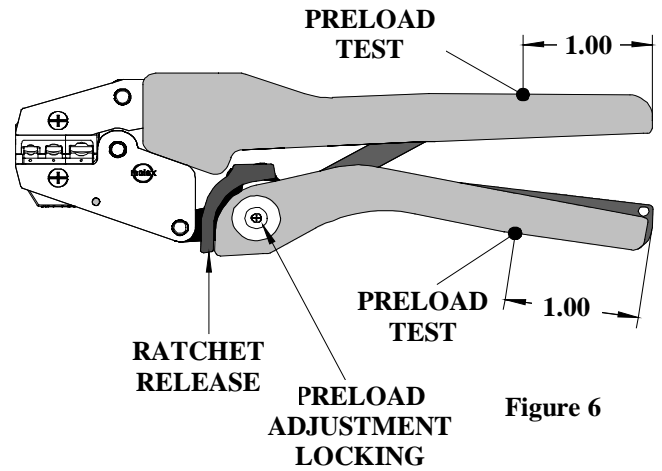
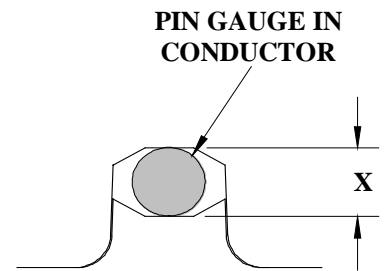

Figure 6

Tool Calibration

A Certificate of Calibration (see last page) was supplied with the tool. To recalibrate this tool, pin gauge measurements should be taken in each conductor nest and compared to this chart. The tool should be lubricated prior to recalibration to ensure consistent measurements. Handle preload is factory set to 25-45 LBS. See How to Adjust Tool Preload (see Figure 6) to recalibrate.



“Confining” Crimp

Nest Color Code	Wire Range		“X” Dimension Conductor Crimp			Crimp Inspection Marking
	AWG	mm ²	Mean	Go	No Go	
Red	18 - 22	0.35 - 0.80	.108	.104	.112	O
Blue	14 - 16	1.30 - 2.00	.117	.112	.122	OO
Yellow	10 - 12	3.30 - 5.00	.147	.143	.152	O

CAUTION: Repetitive use of this tool should be avoided.

Warranty

This tool is for electrical terminal crimping purposes only. This tool is made of the best quality materials. All vital components are long-life tested. All tools are warranted to be free of manufacturing defects for a period of **30 days**. Should such a defect occur, we will repair or exchange the tool free of charge. This repair or exchange will not be applicable to altered, misused, or damaged tools. This tool is designed for hand use only. Any clamping, fixturing, or use of handle extensions voids this warranty.

Hand held crimping tools are intended for low volume, prototyping, or repair requirements only.

CAUTION: Molex crimp specifications are valid only when used with Molex terminals, applicators and tooling.

PARTS LIST

Item	Order No	Description	Quantity
	64001-0300	Hand Crimp Tool	(Figure 7)
1	64000-0076	Repair Kit (Springs, Pins and E-Rings)	1
2	63810-0000	Handle	1
3	64005-0175	Locator Assembly	1
4	64001-0370	Tooling Kit	1
Tooling Kit Only			
5	64001-0114	Conductor Punch	1
6	64001-0112	Conductor Anvil	1
7	64001-0312	Insert Punch	1
8	64001-0311	Insert Anvil	1
9	N/A	4 mm Dia. by 5.0 mm Lg. Roll Pins	2**

** The following purchased parts are available from an Industrial supply company such as MSC (1-800-645-7270).

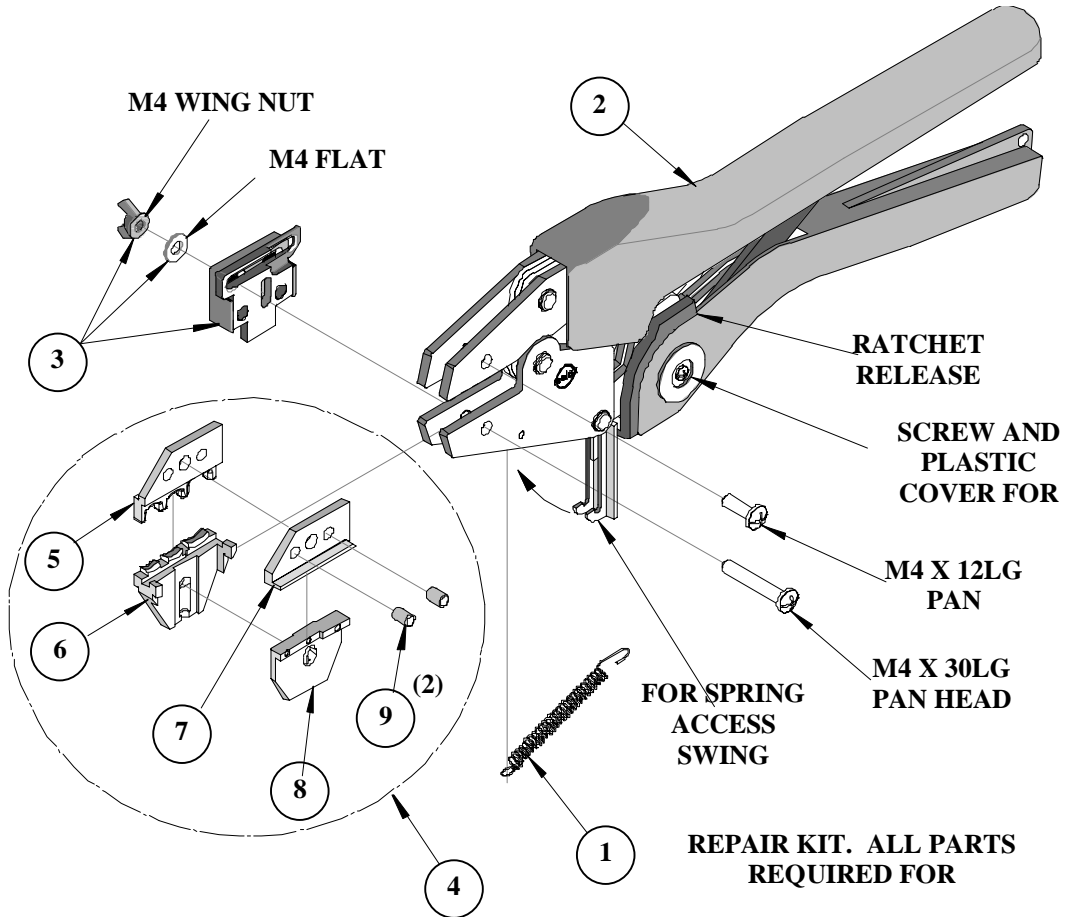
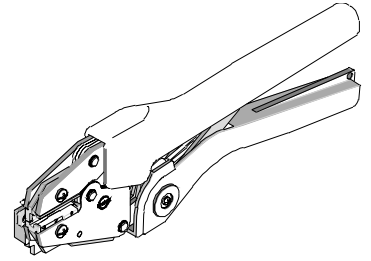

Figure 7



Certificate of Calibration

Tool Order Number _____

Tool Eng. Number _____

Tool Revision _____

Serial Number _____

Date of Manufacture _____

Handle Load Range at 1 inch from the Tips = _____

Actual = _____

Pin Gauge of Conductor Nest/Nests or Slug height if the nest is the "F" Crimp style.

Range Conductor Nest # 1 = _____ Actual = _____

Range Conductor Nest # 2 = _____ Actual = _____

Range Conductor Nest # 3 = _____ Actual = _____

Technician _____

Date of Calibration _____

Calibration should be done every 5,000 cycles or 3 months.

Tools should be lubricated during this operation.

Americas Headquarters
Lisle, Illinois 60532 U.S.A.
1-800-78MOLEX
amerinfo@molex.com

Far East North Headquarters
Yamato, Kanagawa, Japan
81-462-65-2324
feninfo@molex.com

Far East South Headquarters
Jurong, Singapore
65-6-268-6868
fesinfo@molex.com

European Headquarters
Munich, Germany
49-89-413092-0
eurinfo@molex.com

Corporate Headquarters
2222 Wellington Ct.
Lisle, IL 60532 U.S.A.
630-969-4550
Fax: 630-969-1352

Visit our Web site at <http://www.molex.com>