

THIS DRAWING IS UNPUBLISHED. RELEASED FOR PUBLICATION
 © COPYRIGHT - By - ALL RIGHTS RESERVED.

LOC	DIST	REVISIONS			
P	LTR	DESCRIPTION	DATE	DWN	APVD
AF	50	C	REVISED PER ECR-12-013219	08JAN13	KH KR

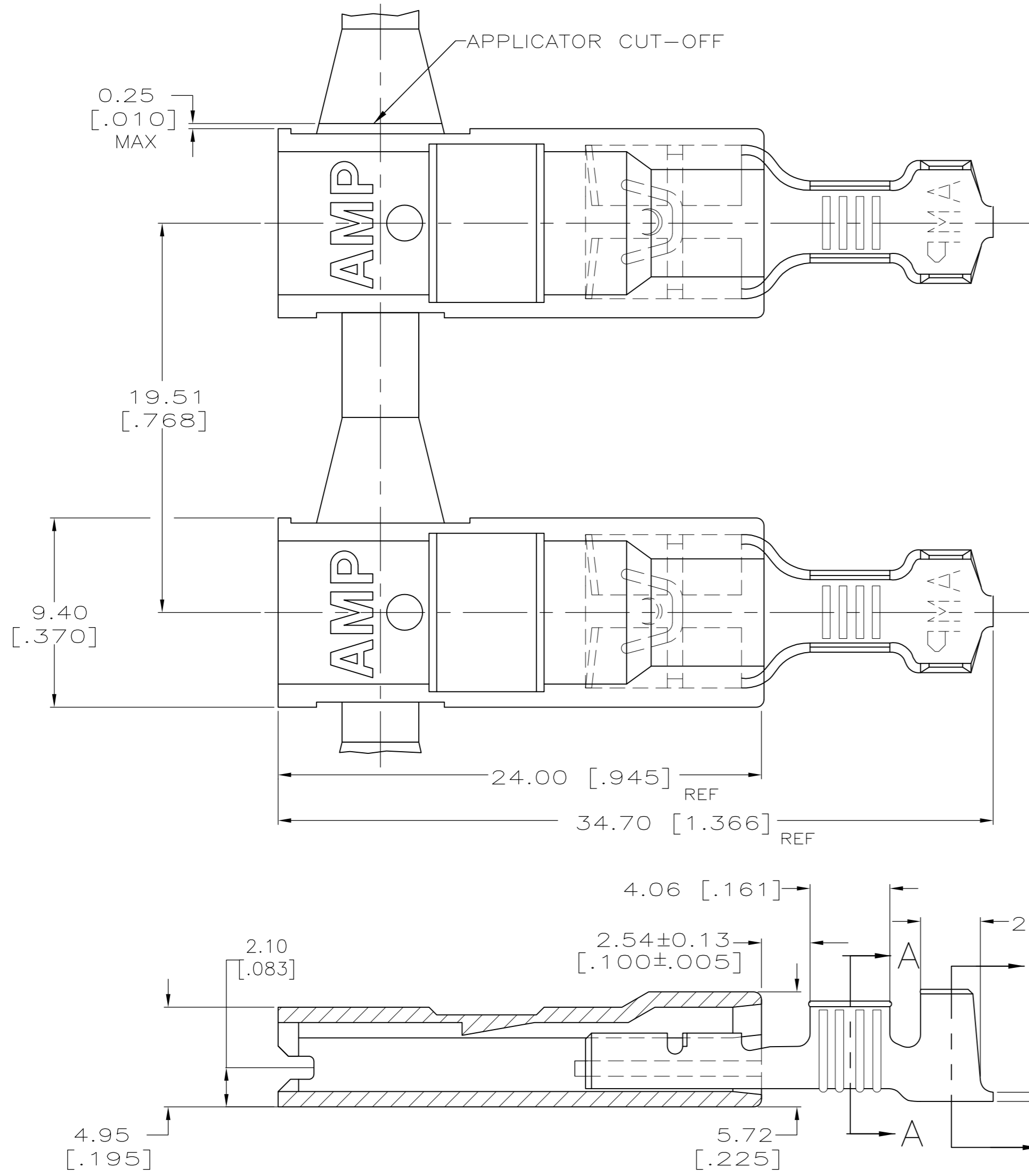

- 1 LOW-INSERTION FASTON TERMINALS, BASE P/N 63306, ARE USED IN THIS PRODUCT.
- 2 TIN PLATE PER 0.001016 [.000040] MIN
- 3 PRELIMINARY - NOT FOR PRODUCTION
- 4 GLOW WIRE APPROVED; CONTACT TE ENGINEERING FOR SPECIFICATION (ALL WALL THICKNESSES ARE BETWEEN 0.4-3.0 [.015-.118])

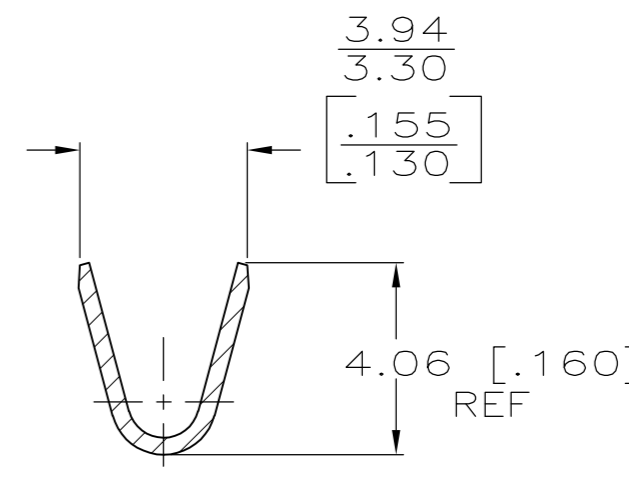

SECTION A-A

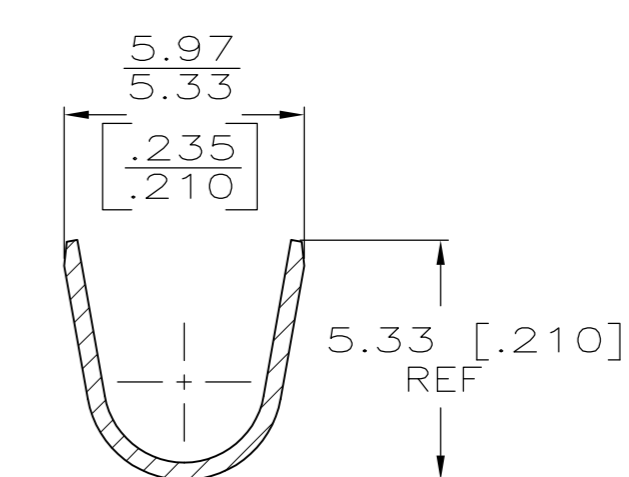

SECTION B-B

STANDARD	2 TIN PLATE	2.79-4.32	0.8-2.0 mm ² [18-14]	0.813 [.032]	521997-2 3
STANDARD	PLAIN	[.110-.170] DIA			521997-1 4
PACKAGING	TERMINAL FINISH	INSULATION RANGE	WIRE SIZE	MATING TAB THK ±0.025 [±.001]	PART NO

THIS DRAWING IS A CONTROLLED DOCUMENT.		DWN 30JAN07 RAGHAVENDRA	STE TE Connectivity	
DIMENSIONS: mm [INCHES]		CHK 30JAN07 G.D.PORTA		
TOLERANCES UNLESS OTHERWISE SPECIFIED:		APVD 30JAN07 G.D.PORTA	NAME	
0 PLC ± -		PRODUCT SPEC	ASSEMBLY, ULTRA-POD, RECEPTACLE, 6.35 [.250] SERIES	
1 PLC ± -		APPLICATION SPEC	SIZE	CAGE CODE
2 PLC ± -		108-1285	A2	00779
3 PLC ± 0.25 [.010]		114-2124	DRAWING NO	RESTRICTED TO
4 PLC ± -			C=521997	-
ANGLES ± -		WEIGHT	SCALE	SHEET
FINISH		CUSTOMER DRAWING	5:1	1 of 1
HOUSING - V2 NYLON	FINISH		REV	C
TERMINAL - BRASS	HOUSING - NATURAL (WHITE)			
	TERMINAL - SEE TABLE			