

REVISIONS				
P.	LTN	DESCRIPTION	DATE	APP'D
B5		REVISED PER ECO-13-020287	16JAN2014	DD DS
B6		REVISED PER ECO-15-000098	06JAN2015	DD DS
B7		REVISED PER ECO-15-003872	25MAR2015	DD DS

- △ ACCEPTS #3 SELF TAPPING THREAD FORMING SCREWS OR METRIC EQUIVALENT. DRIVE TO 0.6-0.8 N-m.
- △ HOUSING COLORS ARE MECHANICALLY KEYS TO MATE ONLY WITH IDENTICALLY COLORED PLUG ASSEMBLIES.
- 3. HEADER MATES TO PLUG ASSEMBLY 776273 WHICH USES REELED TERMINAL 770520 AND LOOSE PIECE TERMINAL 770854
- △ MATERIAL: HEADER HOUSING - GLASS FILLED PBT  
PIN - TIN OR GOLD PLATED BRASS
- △ DATE CODE TO BE BRANDED ON THIS SURFACE PER TE SPEC 102-60. USE 5 DIGIT CODE: FIRST 2 DIGITS = YEAR, SECOND 2 DIGITS = WEEK, LAST DIGIT = DAY.

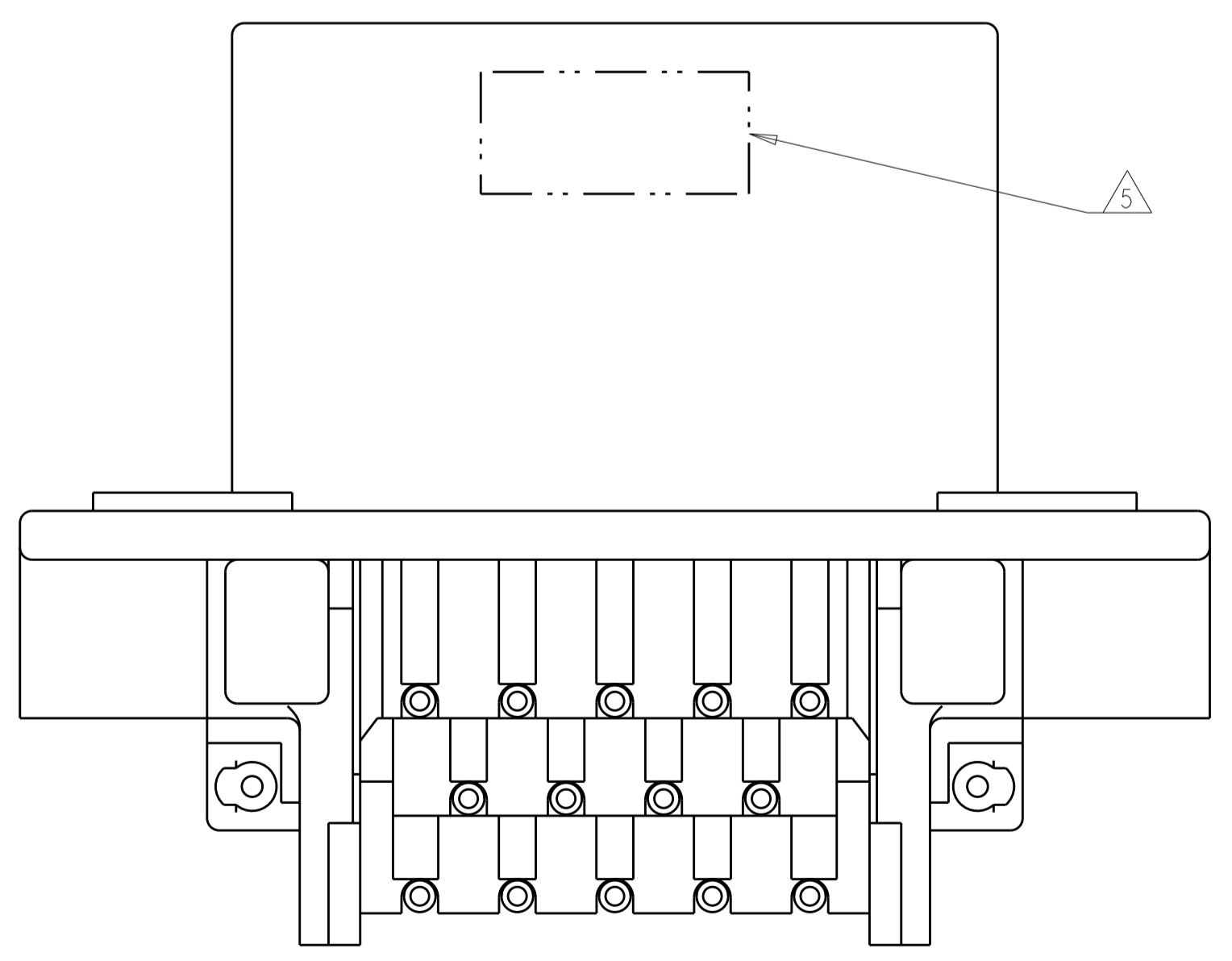
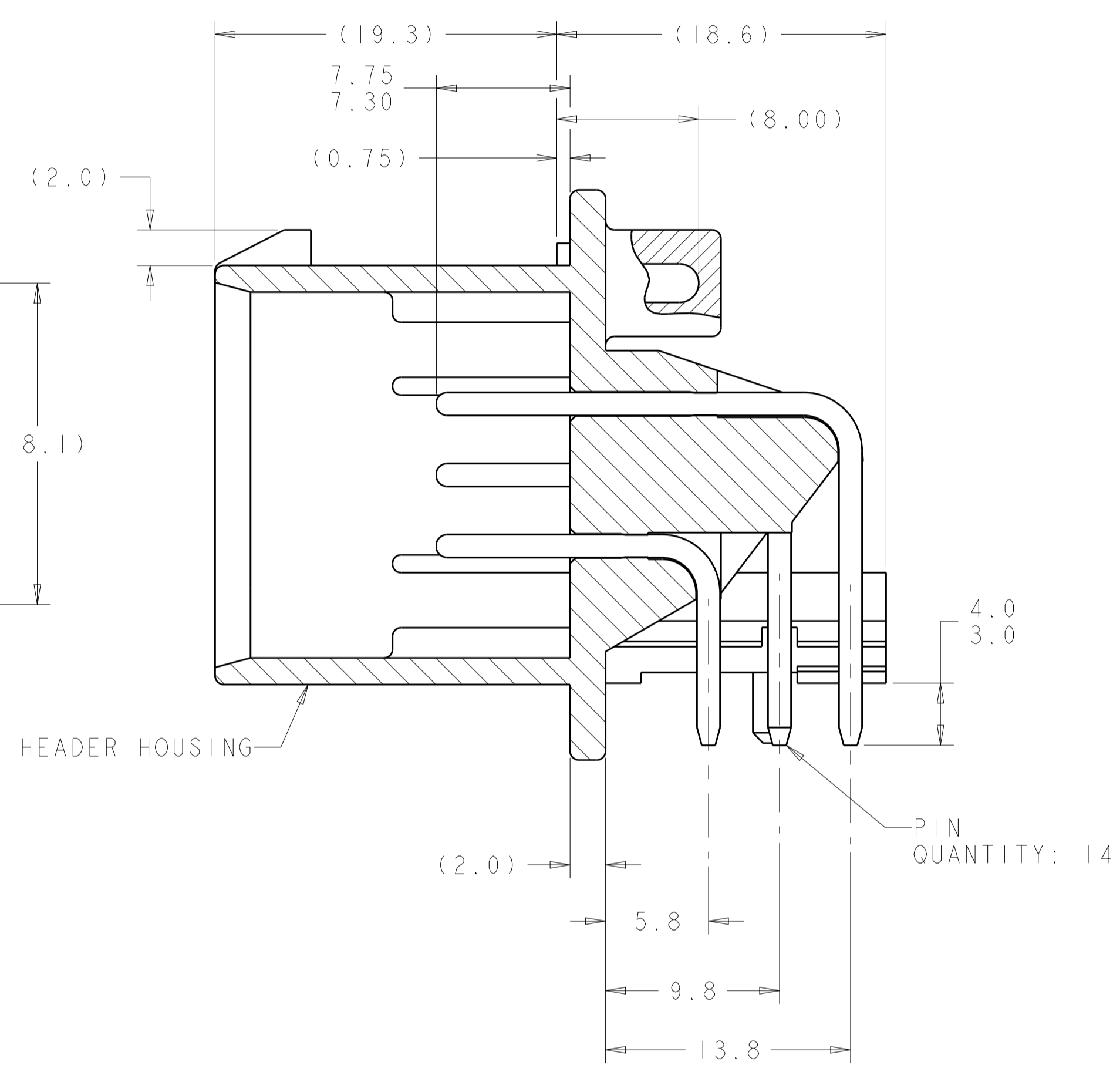
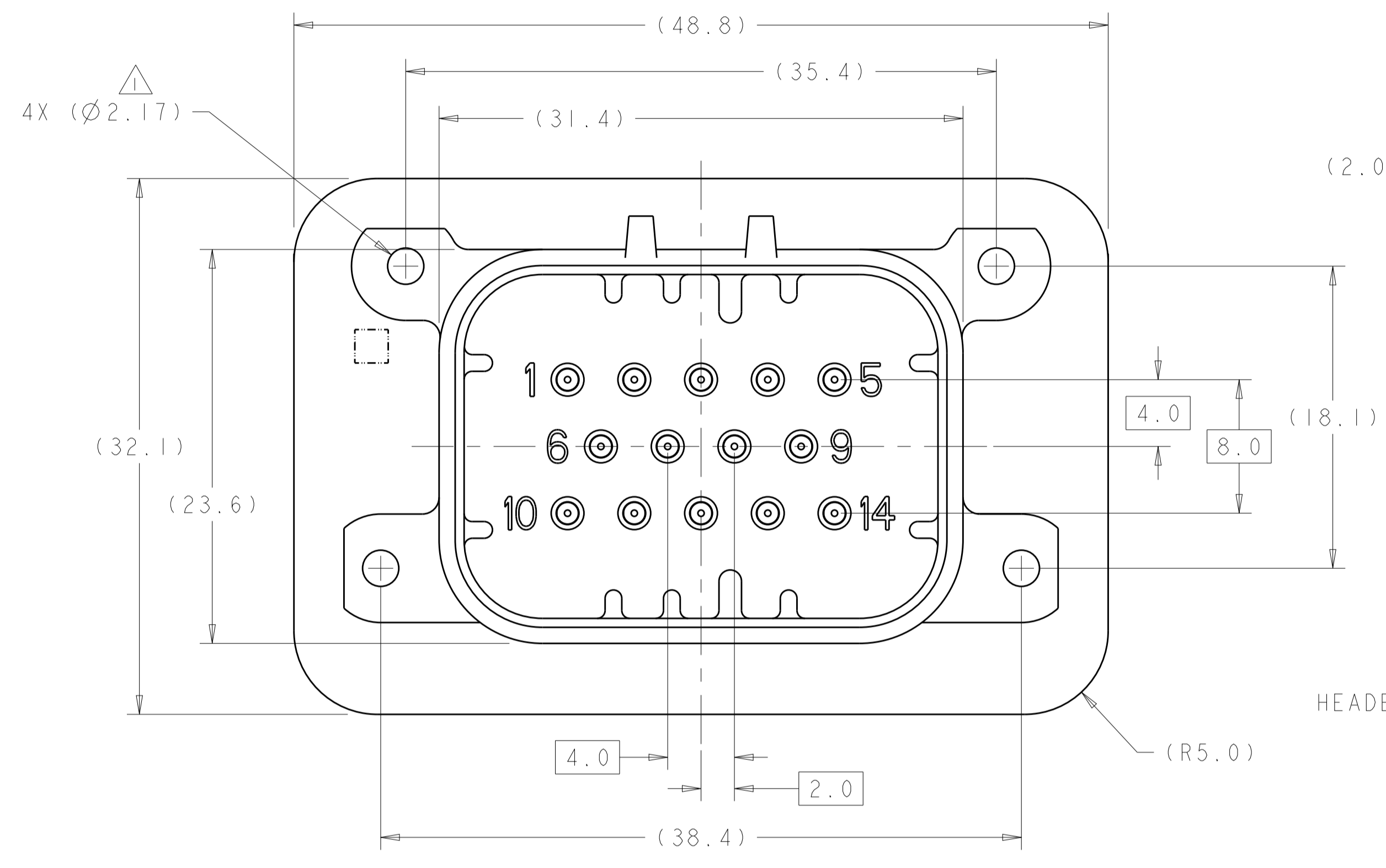

776266-1 & 1-776266-1 SHOWN

HEADER HOUSING COLOR	DESCRIPTION	PART NUMBER
BLUE	DURAGOLD PLATED	1-776266-5
GRAY	DURAGOLD PLATED	1-776266-4
NATURAL	DURAGOLD PLATED	1-776266-2
BLACK	DURAGOLD PLATED	1-776266-1
BLUE	TIN PLATED	776266-5
GRAY	TIN PLATED	776266-4
NATURAL	TIN PLATED	776266-2
BLACK	TIN PLATED	776266-1

THIS DRAWING IS A CONTROLLED DOCUMENT.

TE Connectivity

NAME: HEADER ASSEMBLY, 14 POSITION, RIGHT ANGLE, AMPSEAL

PRODUCT SPEC: 108-1329

APPLICATION SPEC: 114-16016

SIZE: A100779 C=776266

SCALE: 4:1 SHEET 1 OF 2 REV B7

MATERIAL: GLASS FILLED PBT

FINISH: TIN OR GOLD PLATED BRASS

APPROVED: D. STRAUSSER

CHECKED: D. STRAUSSER

DESIGNED: D. DRUMMOND

DATE: 18AUG2010

REVISIONS				
P.	LTH	DESCRIPTION	DATE	OWN APVD
-	-	SEE SHEET 1	-	-

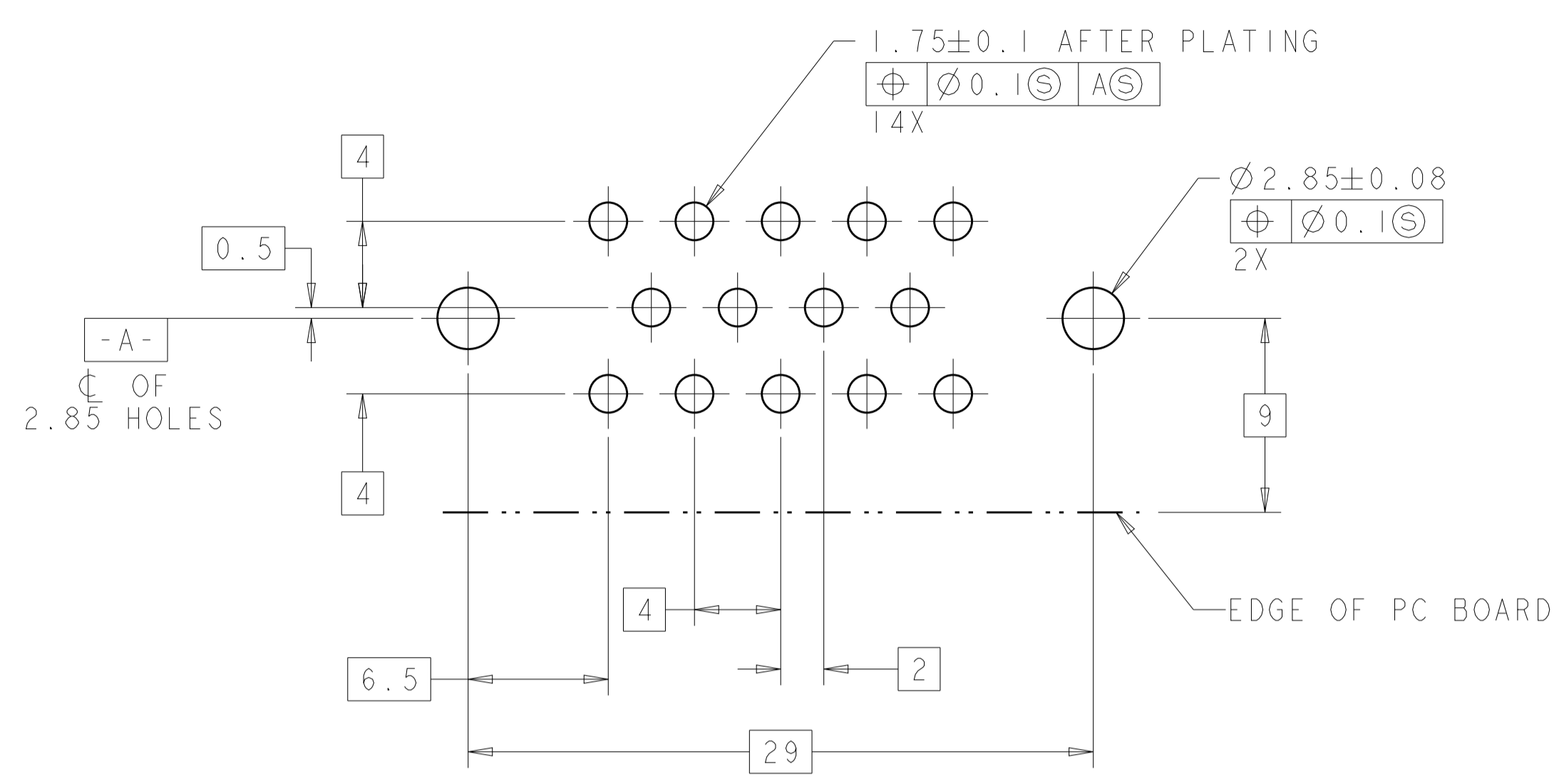

RECOMMENDED PC BOARD LAYOUT FOR 1.57 PC BOARD

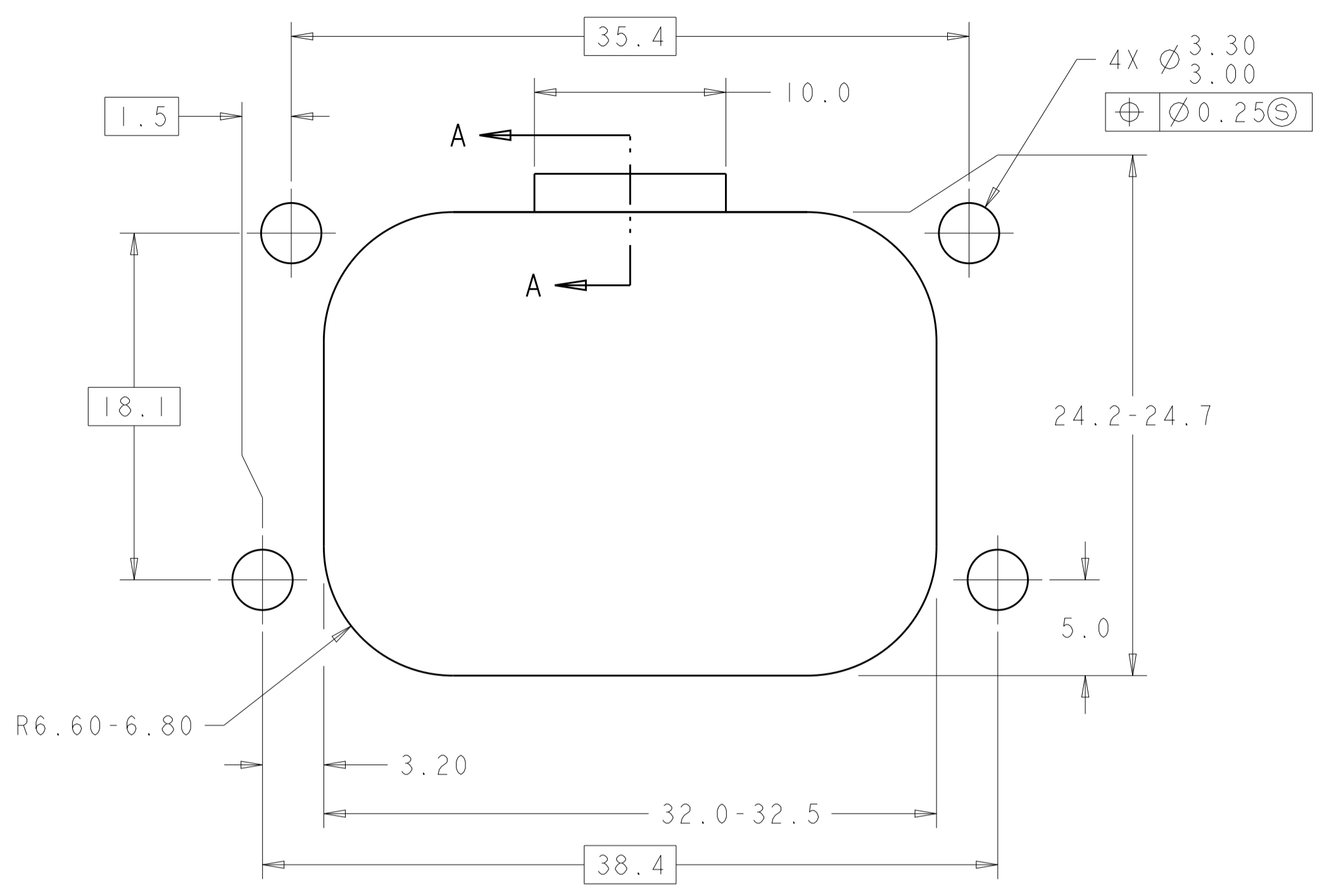

RECOMMENDED MOUNTING HOLE LAYOUT FOR 5.0 MAXIMUM THICK PANEL

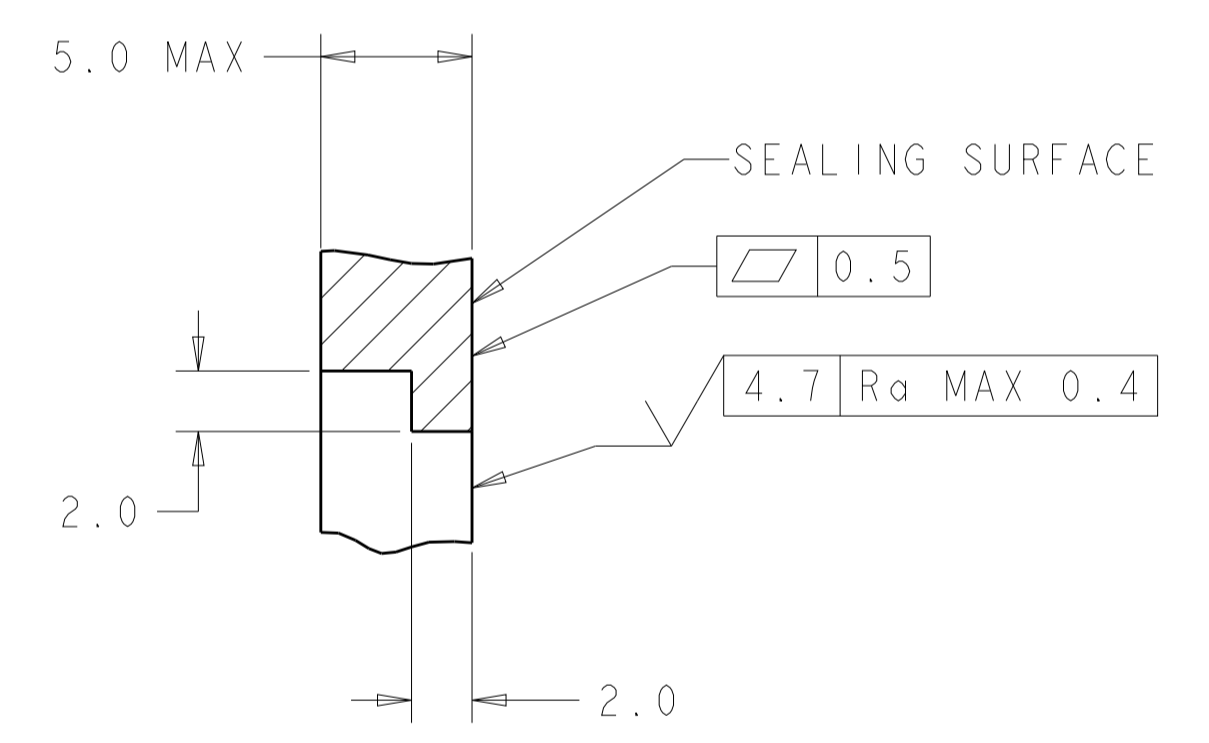
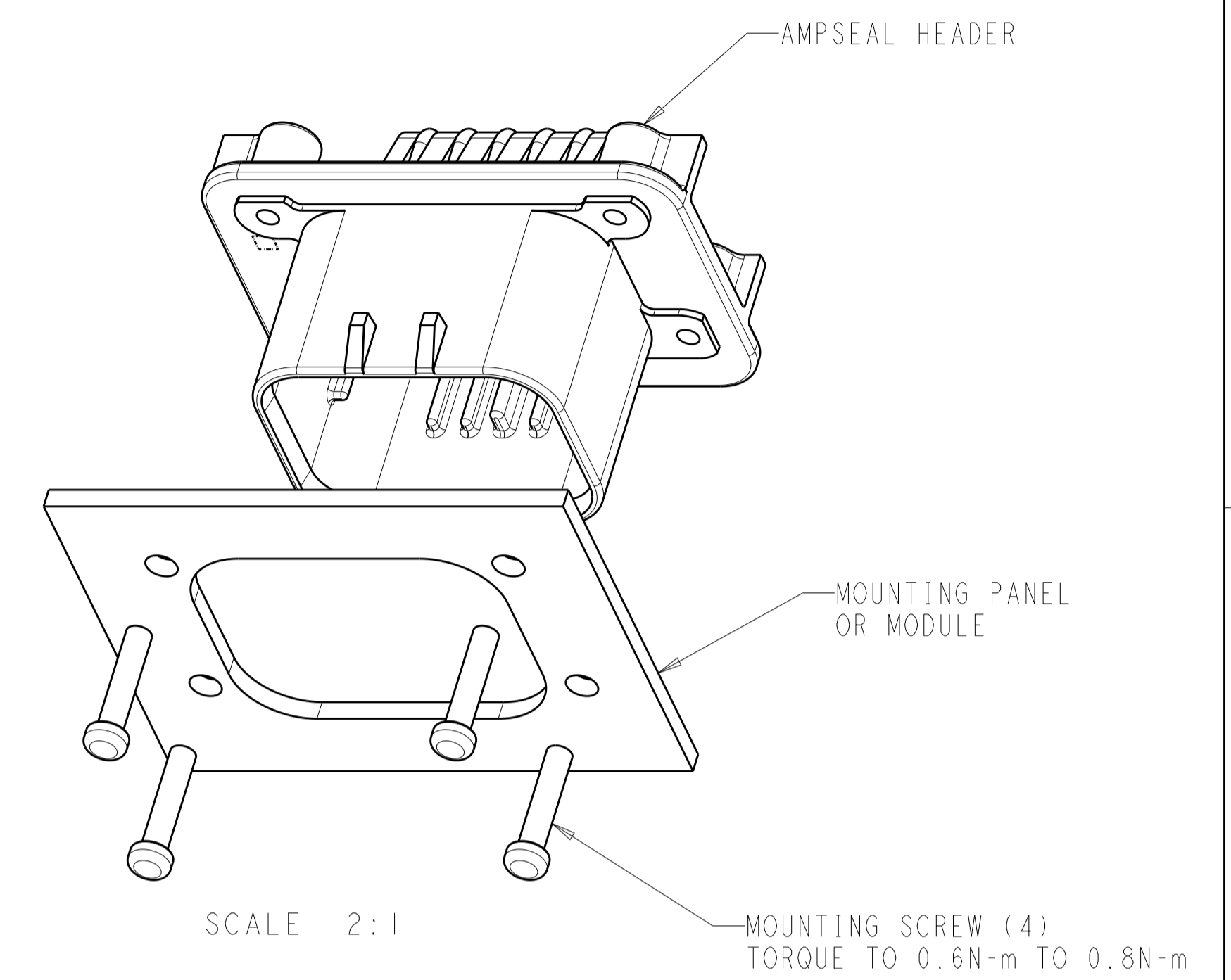

SECTION A-A  
 OPTIONAL CONSTRUCTION IF THICKNESS IS GREATER THEN 2.0

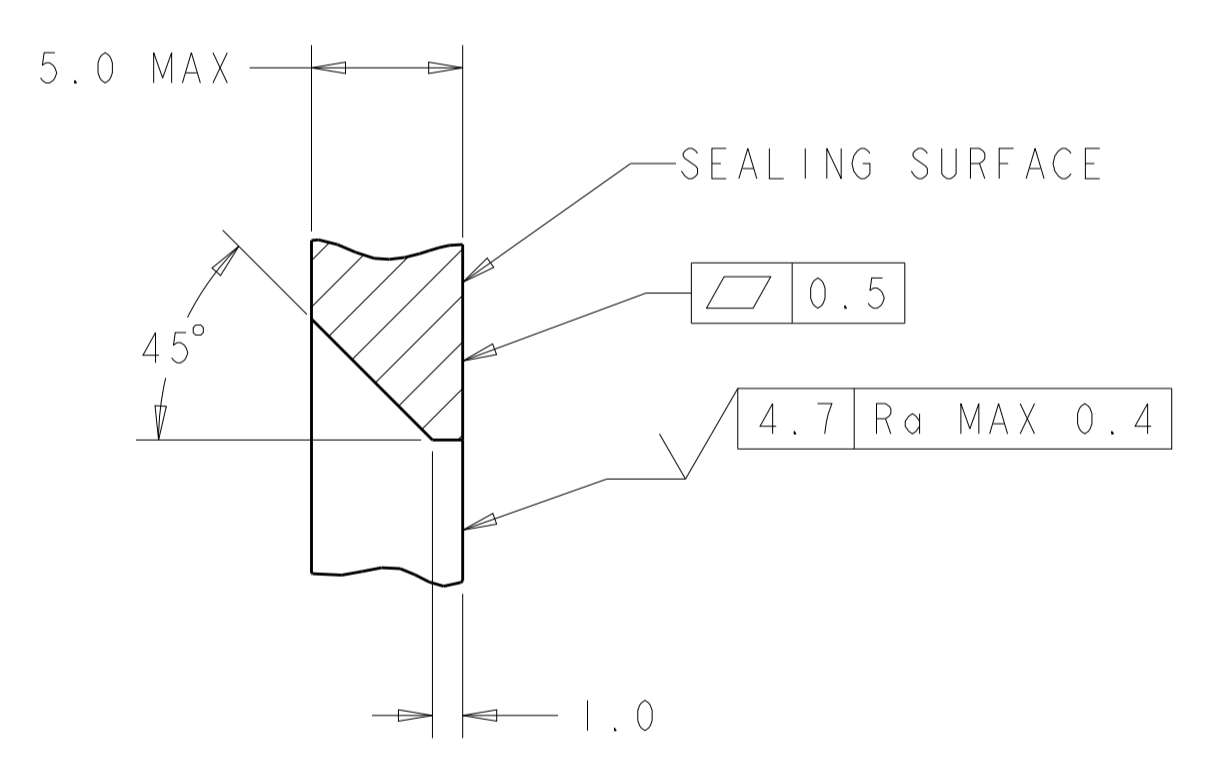

SECTION A-A  
 OPTIONAL CONSTRUCTION IF THICKNESS IS GREATER THEN 2.0

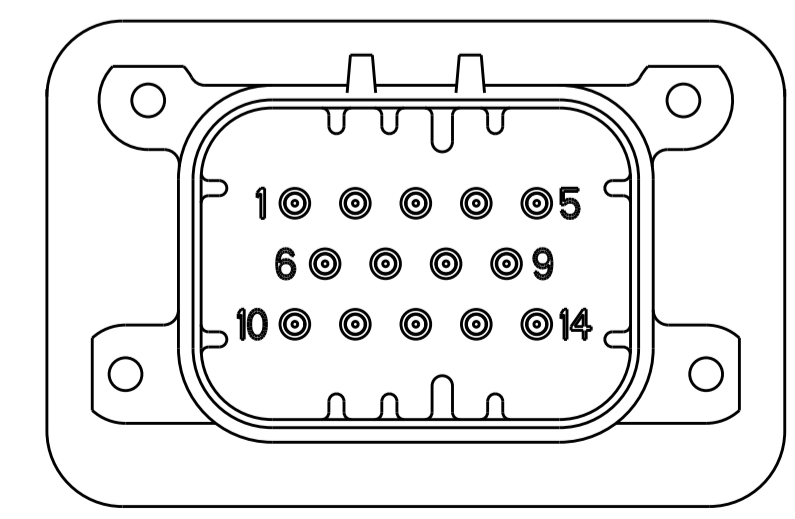
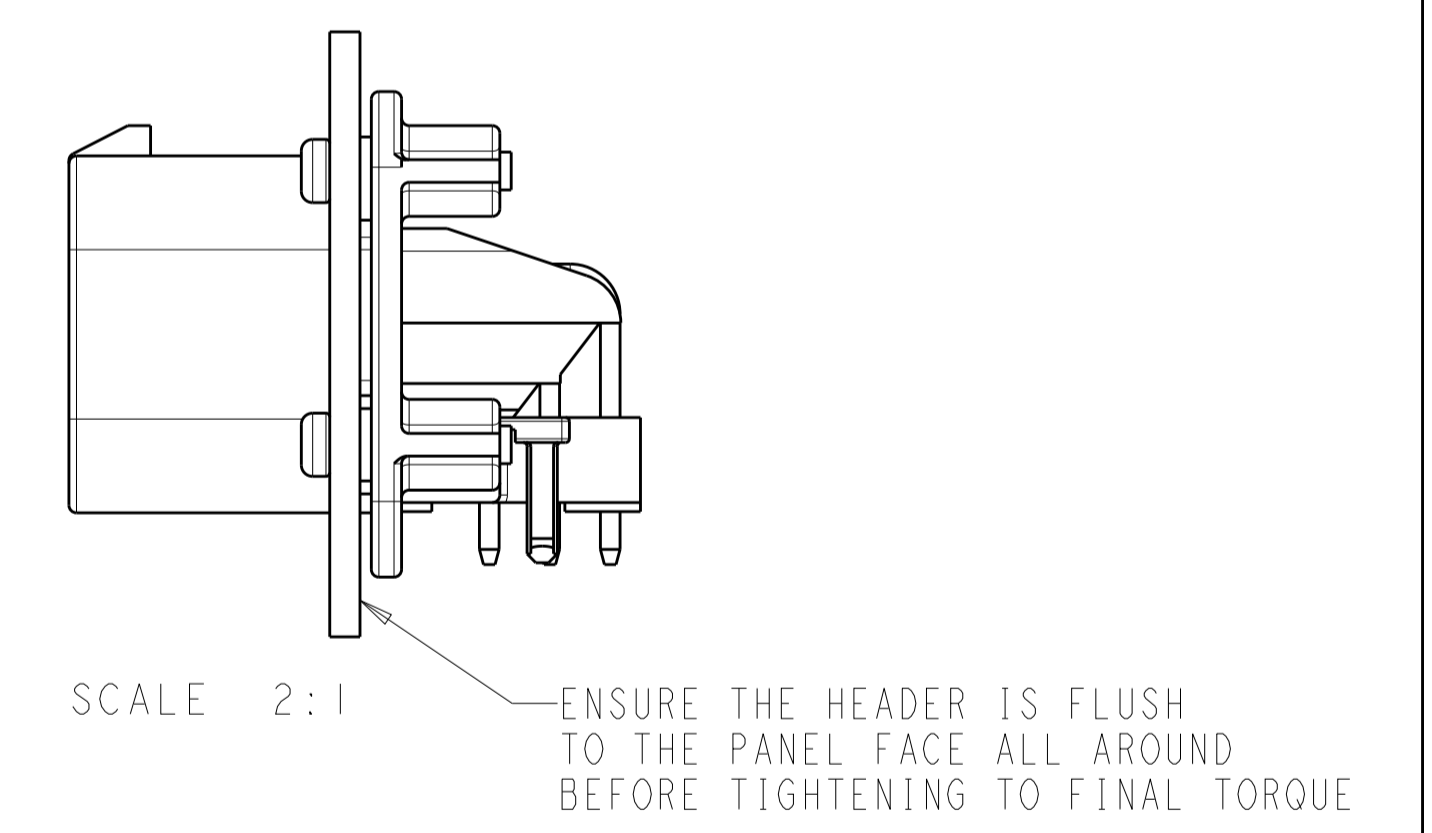

776266-1 & 1-776266-1  
 KEY LOCATION  
 SCALE 2:1

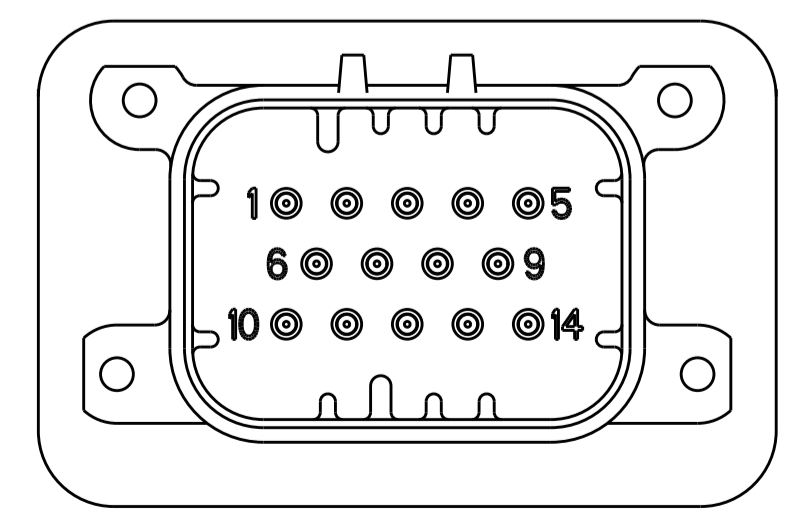

776266-2 & 1-776266-2  
 KEY LOCATION  
 SCALE 2:1

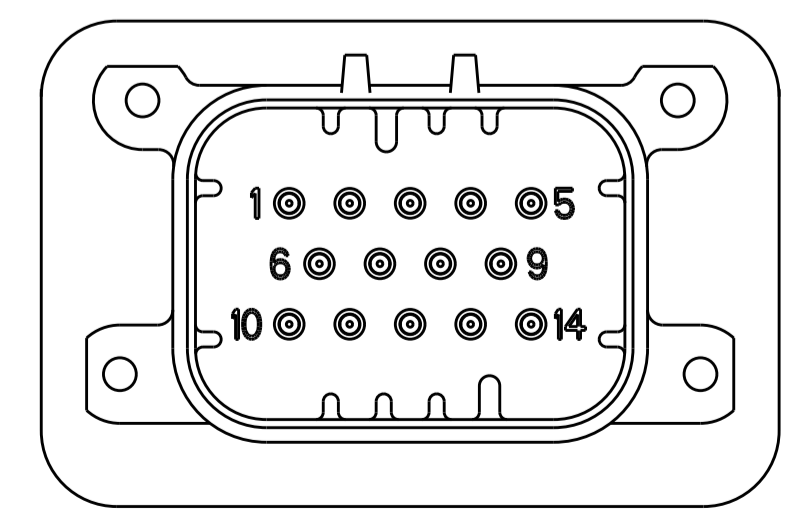

776266-4 & 1-776266-4  
 KEY LOCATION  
 SCALE 2:1

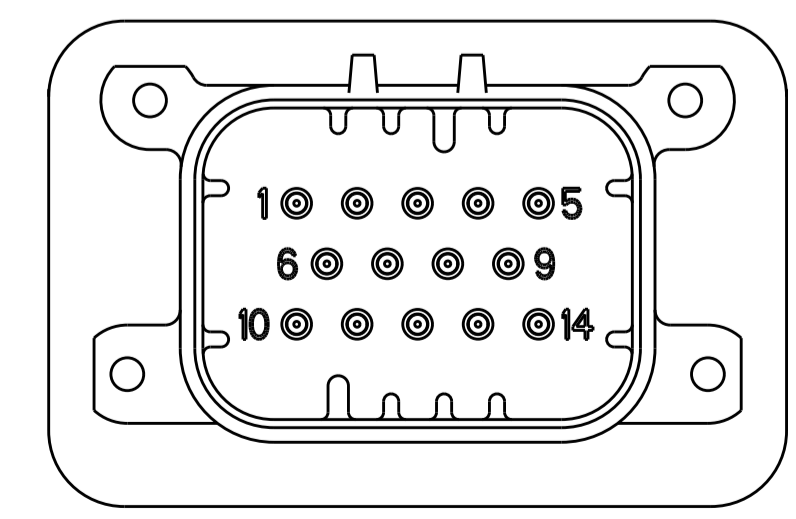

776266-5 & 1-776266-5  
 KEY LOCATION  
 SCALE 2:1

THIS DRAWING IS A CONTROLLED DOCUMENT.		OWN: D. DRUMMOND 18AUG2010	TE Connectivity
DIMENSIONS: mm		CHK: D. STRAUSSER 18AUG2010	
TOLERANCES UNLESS OTHERWISE SPECIFIED:		APVD: D. STRAUSSER 18AUG2010	NAME: HEADER ASSEMBLY, 14 POSITION, RIGHT ANGLE, AMPSEAL
0 PLC	±	PRODUCT SPEC	SIZE: CAGE CODE DRAWING NO
1 PLC	±0.2	108-1329	RESTRICTED TO
2 PLC	±0.13	APPLICATION SPEC	A100779C=776266
3 PLC	±	114-16016	SCALE: 4:1 SHEET 2 OF 2 REV: B7
4 PLC	±	WEIGHT	
ANGLES	±45°	CUSTOMER DRAWING	