

# DATA SHEET

## **TZA3047A; TZA3047B** 30 Mbits/s up to 1.25 Gbits/s laser drivers

Product specification

2003 Jun 05

**30 Mbits/s up to 1.25 Gbits/s laser drivers****TZA3047A; TZA3047B**

<b>CONTENTS</b>	11	<b>AC CHARACTERISTICS</b>
	12	<b>APPLICATION INFORMATION</b>
<b>FEATURES</b>	12.1	Design equations
1.1 General	12.1.1	Bias and modulation currents
1.2 Control features	12.1.2	Average monitor current and extinction ratio
1.3 Protection features	12.1.3	Dual-loop control
<b>2 APPLICATIONS</b>	12.1.4	Alarm operating current
<b>3 GENERAL DESCRIPTION</b>	12.1.5	Alarm monitor current
<b>4 ORDERING INFORMATION</b>	12.1.6	Pulse width adjustment
<b>5 BLOCK DIAGRAM</b>	12.2	TZA3047A with dual-loop control
<b>6 PINNING</b>	12.3	TZA3047B with dual-loop control
<b>7 FUNCTIONAL DESCRIPTION</b>	12.4	TZA3047B with average loop control
7.1 Data and clock input	<b>13 BONDING PAD LOCATIONS</b>	
7.2 Retiming	<b>14 PACKAGE OUTLINE</b>	
7.3 Pulse width adjustment	<b>15 SOLDERING</b>	
7.4 Modulator output stage	15.1	Introduction to soldering surface mount packages
7.5 Dual-loop control	15.2	Reflow soldering
7.6 Average loop control	15.3	Wave soldering
7.7 Direct current setting	15.4	Manual soldering
7.8 Soft start	15.5	Suitability of surface mount IC packages for wave and reflow soldering methods
7.9 Alarm functions	<b>16 DATA SHEET STATUS</b>	
7.10 Enable	<b>17 DEFINITIONS</b>	
7.11 Reference block	<b>18 DISCLAIMERS</b>	
<b>8 LIMITING VALUES</b>		
<b>9 THERMAL CHARACTERISTICS</b>		
<b>10 DC CHARACTERISTICS</b>		

## 30 Mbits/s up to 1.25 Gbits/s laser drivers

## TZA3047A; TZA3047B

**1 FEATURES****1.1 General**

- 30 Mbits/s to 1.25 Gbits/s
- Bias current up to 100 mA
- Modulation current up to 100 mA
- Rise and fall times typical 120 ps
- Jitter below 30 ps (peak-to-peak value)
- Modulation output voltage up to 2 V dynamic range
- 1.2 V minimum voltage on the modulation output pin and 0.4 V minimum voltage on pin BIAS
- Retiming function via external clock with disable option
- Pulse width adjustment function with disable option
- Positive Emitter Coupled Logic (PECL), Low Voltage Positive Emitter Coupled Logic (LVPECL) and Current-Mode Logic (CML) compatible data and clock inputs
- Internal common mode voltage available for AC-coupled data and clock inputs and for single-ended applications
- 3.3 V supply voltage
- TZA3047A: AC-coupled laser for 3.3 V laser supply
- TZA3047B: DC-coupled laser for 3.3 V and 5 V laser supply.

**1.2 Control features**

- Dual-loop control for constant and accurate optical average power level and extinction ratio
- Optional average power loop control (up to 1.25 Gbits/s)
- Optional direct setting of modulation and bias currents.

**1.3 Protection features**

- Alarm function on operating current
- Alarm function on monitor current
- Enable function on bias and modulation currents
- Soft start on bias and modulation currents.

**2 APPLICATIONS**

- SDH/SONET optical transmission systems.

**3 GENERAL DESCRIPTION**

The TZA3047 is a fully integrated laser driver for optical transmission systems with data rates up to 1.25 Gbits/s. The TZA3047 incorporates all the necessary control and protection functions for a laser driver application with very few external components required and low power dissipation. The dual-loop controls the average monitor current in a programmable range from 150  $\mu$ A to 1300  $\mu$ A and the extinction ratio in a programmable range from 5 to 15 (linear scale).

The design is made in the Philips BiCMOS RF process and is available in a HBCC32 package or as bare die. The TZA3047A is intended for use in an application with an AC-coupled laser diode with a 3.3 V laser supply voltage. The TZA3047B is intended for use in an application with a DC-coupled laser diode for both 3.3 and 5 V laser supply voltages.

**4 ORDERING INFORMATION**

TYPE NUMBER	PACKAGE		
	NAME	DESCRIPTION	VERSION
TZA3047AVH	HBCC32	plastic thermal enhanced bottom chip carrier; 32 terminals;	SOT560-1
TZA3047BVH	HBCC32	body 5 × 5 × 0.65 mm	
TZA3047UH	–	bare die; 2 560 × 2 510 × 380 $\mu$ m	–

30 Mbits/s up to 1.25 Gbits/s laser drivers

TZA3047A; TZA3047B

5 BLOCK DIAGRAM

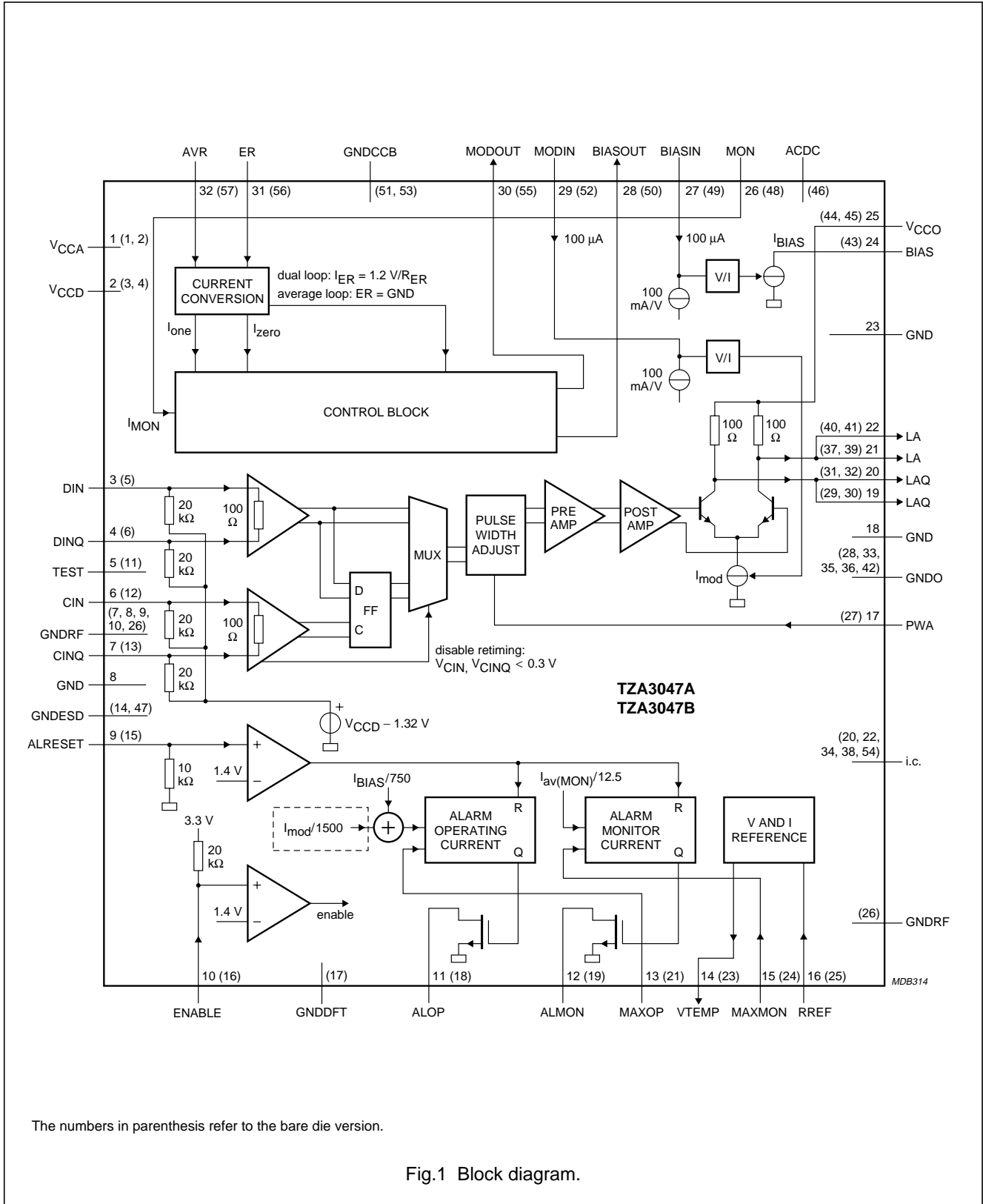

Fig.1 Block diagram.

## 30 Mbits/s up to 1.25 Gbits/s laser drivers

## TZA3047A; TZA3047B

## 6 PINNING

SYMBOL	PIN	PAD <sup>(1)</sup>	DESCRIPTION
GND	die pad	substrate	common ground plane for $V_{CCA}$ , $V_{CCD}$ , $V_{CCO}$ , RF and I/O; must be connected to ground
$V_{CCA}$	1	1	analog supply voltage
$V_{CCA}$	–	2	analog supply voltage
$V_{CCD}$	2	3	digital supply voltage
$V_{CCD}$	–	4	digital supply voltage
DIN	3	5	non-inverted data input (RF input)
DINQ	4	6	inverted data input (RF input)
GNDRF	–	7	ground
GNDRF	–	8	ground
GNDRF	–	9	ground
GNDRF	–	10	ground
TEST	5	11	test pin or test pad; must be connected to ground
CIN	6	12	non-inverted clock input (RF input)
CINQ	7	13	inverted clock input (RF input)
GND	8	–	ground
GND ESD	–	14	ground
ALRESET	9	15	alarm reset input; resets ALMON and ALOP alarms
ENABLE	10	16	enable input for modulation and bias current
GND DFT	–	17	ground
ALOP	11	18	alarm output on operating current (open-drain)
ALMON	12	19	alarm output on monitor diode current (open-drain)
i.c.	–	20	internally connected
MAXOP	13	21	threshold level input for alarm on operating current
i.c.	–	22	internally connected
VTEMP	14	23	temperature dependent voltage output source
MAXMON	15	24	threshold level input for alarm on monitor diode current
RREF	16	25	reference current input; must be connected to ground with an accurate (1%) 10 k $\Omega$ resistor
GNDRF	–	26	ground
PWA	17	27	pulse width adjustment input
GND	18	–	ground
GND O	–	28	ground
LAQ	19	29	inverted laser modulation output (RF output); output for dummy load
LAQ	–	30	inverted laser modulation output (RF output); output for dummy load
LAQ	20	31	inverted laser modulation output (RF output); output for dummy load
LAQ	–	32	inverted laser modulation output (RF output); output for dummy load
GND O	–	33	ground
i.c.	–	34	internally connected
GND O	–	35	ground

## 30 Mbits/s up to 1.25 Gbits/s laser drivers

## TZA3047A; TZA3047B

SYMBOL	PIN	PAD <sup>(1)</sup>	DESCRIPTION
GNDO	–	36	ground
LA	21	37	non-inverted laser modulation output (RF output); output for laser
i.c.	–	38	internally connected
LA	–	39	non-inverted laser modulation output (RF output); output for laser
LA	22	40	non-inverted laser modulation output (RF output); output for laser
LA	–	41	non-inverted laser modulation output (RF output); output for laser
GND	23	–	ground
GNDO	–	42	ground
BIAS	24	43	current source output for the laser bias current
V <sub>CCO</sub>	25	44	supply voltage for the output stage and the laser diode
V <sub>CCO</sub>	–	45	supply voltage for the output stage and the laser diode
ACDC	–	46	AC or DC coupled laser; note 2
GNDESD	–	47	ground
MON	26	48	input for the monitor photo diode (RF input)
BIASIN	27	49	input for the bias current setting
BIASOUT	28	50	output of the control block for the bias current
GNDCCB	–	51	ground
MODIN	29	52	input for the modulation current setting
GNDCCB	–	53	ground
i.c.	–	54	internally connected
MODOUT	30	55	output of the control block for the modulation current
ER	31	56	input for the optical extinction ratio setting
AVR	32	57	input for the optical average power level setting

**Notes**

1. All ground pads must be connected to ground.
2. ACDC pad must be left unconnected for AC-coupling applications. For DC-coupling applications, connect this pad to ground.

30 Mbits/s up to 1.25 Gbits/s laser drivers

TZA3047A; TZA3047B

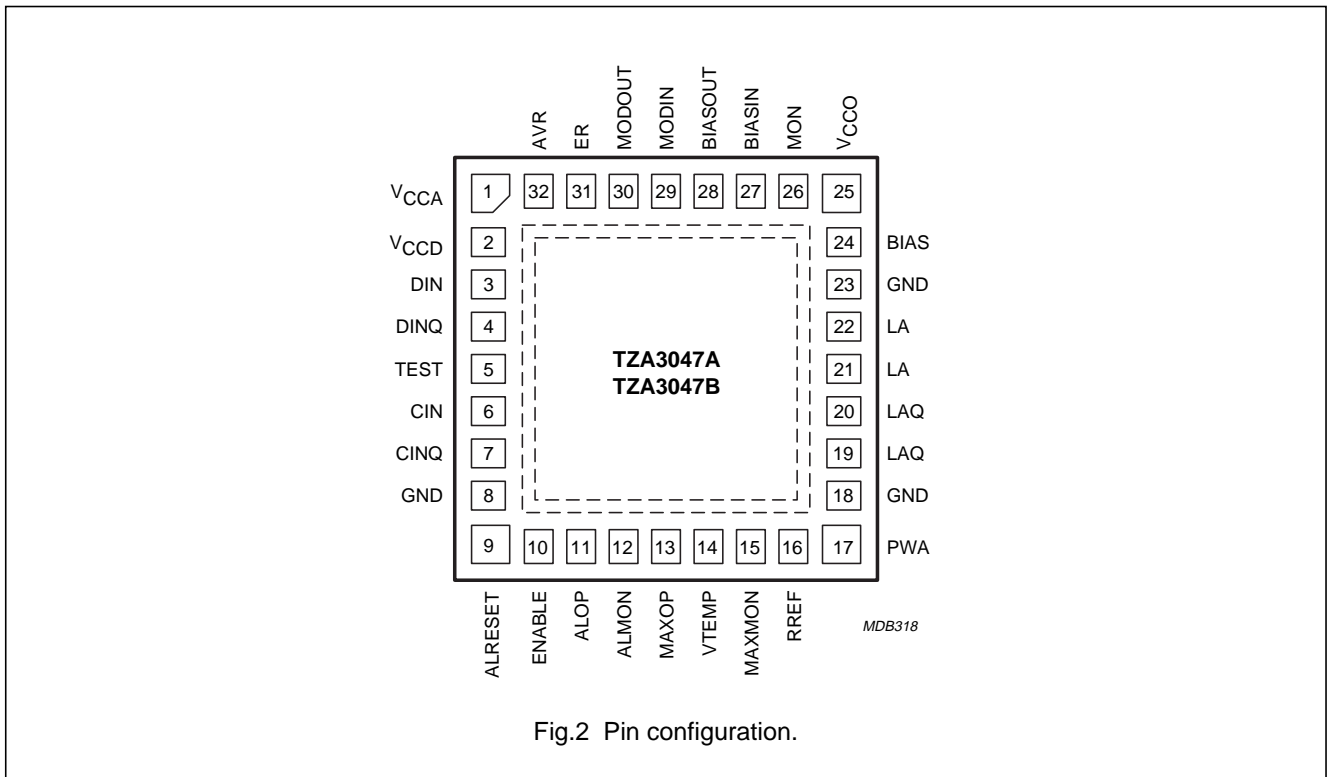

Fig.2 Pin configuration.

7 FUNCTIONAL DESCRIPTION

7.1 Data and clock input

The TZA3047 operates with differential Positive Emitter Coupled Logic (PECL), Low Voltage Positive Emitter Coupled Logic (LVPECL) and Current-Mode Logic (CML) data and clock inputs with a voltage swing from 100 mV to 1 V (p-p). It is assumed that both the data and clock inputs carry a complementary signal with the specified peak-to-peak value (true differential excitation).

The circuit generates an internal common mode voltage for AC-coupled data and clock inputs and for single-ended applications.

If  $V_{DIN} > V_{DINQ}$ , the modulation current is sunk by the LA pins and corresponds to an optical 'one' level of the laser.

7.2 Retiming

The retiming function synchronizes the data with the clock to improve the jitter performance. The data latch switches on the rising edge of the clock input. The retiming function is disabled when both clock inputs are below 0.3 V.

At start-up the initial polarity of the laser is unknown before the first rising edge of the clock input.

7.3 Pulse width adjustment

The on-duration of the laser current can be adjusted from -100 to +100 ps. The adjustment time is set by resistor  $R_{PWA}$ . The maximum allowable capacitive load on pin PWA is 100 pF. Pulse width adjustment is disabled when pin PWA is short-circuited to ground.

7.4 Modulator output stage

The output stage is a high-speed bipolar differential pair with typical rise and fall times of 120 ps and with a modulation current source of up to 100 mA when the LA pins are connected to  $V_{CCO}$ .

The modulation current switches between the LA and LAQ outputs. For a good RF performance the inactive branch carries a small amount of the modulation current.

The LA output is optimized for the laser allowing a 2 V dynamic range and a 1.2 V minimum voltage. The LAQ output is optimized for the dummy load.

The output stage of the TZA3047A is optimized for AC-coupled lasers and the output stage of the TZA3047B is optimized for DC-coupled lasers.

The BIAS output is optimized for low voltage requirements (0.4 V minimum for a 3.3 V laser supply; 0.8 V minimum for a 5 V laser supply).

## 30 Mbits/s up to 1.25 Gbits/s laser drivers

## TZA3047A; TZA3047B

### 7.5 Dual-loop control

The TZA3047 incorporates a dual-loop control for a constant, accurate and temperature-independent control of the optical average power level and the extinction ratio. The dual-loop guarantees constant optical 'one' and 'zero' levels which are independent of the laser temperature and the laser age.

The dual-loop operates by monitoring the current of the monitor photodiode which is directly proportional to the laser emission. The 'one' and 'zero' current levels of the monitor diode are captured by the detector of the dual-loop control. Pin MON for the monitor photodiode current is an RF input.

The average monitor current is programmable over a wide current range from 150 to 1300  $\mu\text{A}$  for both the dual-loop control and the average loop control. The extinction ratio is programmable from 5 to 15.

The maximum allowable capacitive load on pins AVR, ER, BIASOUT and MODOUT is 100 pF.

### 7.6 Average loop control

The average power control loop maintains a constant average power level of the monitor current over temperature and lifetime of the laser. The average loop control is activated by short-circuiting pin ER to ground.

### 7.7 Direct current setting

The TZA3047 can also operate in open-loop mode with direct setting of the bias and modulation currents. The bias and modulation current sources are transconductance amplifiers and the output currents are determined by the BIASIN and MODIN voltages respectively. The bias current source has a bipolar output stage with minimum output capacitance for optimum RF performance.

### 7.8 Soft start

At power-up the bias and modulation current sources are released when  $V_{\text{CCA}} > 2.7 \text{ V}$  and the reference voltage has reached the correct value of 1.2 V.

The control loop starts with minimum bias and modulation current at power-up and when the device is enabled. The current levels increase until the MON input current matches the programmed average level and, in the case of dual-loop control, the extinction ratio.

### 7.9 Alarm functions

The TZA3047 features two alarm functions for the detection of excessive laser operating current and monitor diode current due to laser ageing, laser malfunctioning or a too high laser temperature. The alarm threshold levels are programmed by a resistor or a current source. In the TZA3047A, for the AC-coupled application, the operating current is equal to the bias current. In the TZA3047B, for the DC-coupled application, the operating current equals the bias current plus half of the modulation current.

### 7.10 Enable

A LOW level on the enable input disables the bias and modulation current sources: the laser is off. A HIGH level on the enable input or an open enable input switches both current sources on: the laser is operational.

### 7.11 Reference block

The reference voltage is derived from a band gap circuit and is available at pin RREF. An accurate (1%) 10 k $\Omega$  resistor has to be connected to pin RREF to provide the internal reference current. The maximum capacitive load on pin RREF is 100 pF.

The reference voltage on the setting pins (MAXOP, MAXMON, PWA, ER and AVR) is buffered and derived from the band gap voltage.

The output voltage on pin VTEMP reflects the junction temperature of the TZA3047, the temperature coefficient of  $V_{\text{VTEMP}}$  equals  $-2.2 \text{ mV/K}$ .



## 30 Mbits/s up to 1.25 Gbits/s laser drivers

## TZA3047A; TZA3047B

**8 LIMITING VALUES**

In accordance with the Absolute Maximum Rating System (IEC 60134); all voltages are referenced to ground; positive currents flow into the IC.

SYMBOL	PARAMETER	CONDITION	MIN.	MAX.	UNIT
V <sub>CCD</sub>	digital supply voltage		-0.5	+3.5	V
V <sub>CCA</sub>	analog supply voltage		-0.5	+3.5	V
V <sub>CCO</sub>	output stage supply voltage	3.3 V laser supply	-0.5	+3.5	V
		5 V laser supply (TZA3047B only)	-0.5	+5.3	V
V <sub>o(LA)</sub>	output voltage at pin LA	TZA3047A; V <sub>CCO</sub> = 3.3 V	1.2	4.5	V
		TZA3047B; V <sub>CCO</sub> = 3.3 V	0.8	4.1	V
		TZA3047B; V <sub>CCO</sub> = 5 V	1.2	4.5	V
V <sub>o(LAQ)</sub>	output voltage at pin LAQ	TZA3047A; V <sub>CCO</sub> = 3.3 V	1.8	4.5	V
		TZA3047B; V <sub>CCO</sub> = 3.3 V	1.6	4.5	V
		TZA3047B; V <sub>CCO</sub> = 5 V	2.0	5.2	V
V <sub>BIAS</sub>	bias voltage	TZA3047A; V <sub>CCO</sub> = 3.3 V	0.4	3.6	V
		TZA3047B; V <sub>CCO</sub> = 3.3 V	0.4	3.6	V
		TZA3047B; V <sub>CCO</sub> = 5 V	0.8	4.1	V
V <sub>n</sub>	voltage on other input and output pins				
	analog inputs and outputs		-0.5	V <sub>CCA</sub> + 0.5	V
	digital inputs and outputs		-0.5	V <sub>CCD</sub> + 0.5	V
I <sub>n</sub>	input current on pins				
	MAXOP, MAXMON, RREF, PWA, ER and AVR		-1.0	0	mA
	VTEMP, BIASOUT and MODOUT		-1.0	+1.0	mA
	ALOP, ALMON and MON		0	5.0	mA
T <sub>amb</sub>	ambient temperature		-40	+85	°C
T <sub>j</sub>	junction temperature		-40	+125	°C
T <sub>stg</sub>	storage temperature		-65	+150	°C

**9 THERMAL CHARACTERISTICS**

In compliance with JEDEC standards JESD51-5 and JESD51-7.

SYMBOL	PARAMETER	CONDITIONS	VALUE	UNIT
R <sub>th(j-a)</sub>	thermal resistance from junction to ambient	4 layer printed circuit board in still air with 9 plated vias connected with the heatsink and the first ground plane in the PCB	35	K/W
		HBCC32 die pad soldered to PCB	60	K/W

## 30 Mbits/s up to 1.25 Gbits/s laser drivers

## TZA3047A; TZA3047B

**10 DC CHARACTERISTICS**

$T_{amb} = -40$  to  $+85$  °C;  $R_{th(j-a)} = 35$  K/W;  $P_{tot} = 400$  mW;  $V_{CCA} = 3.14$  to  $3.47$  V;  $V_{CCD} = 3.14$  to  $3.47$  V;  
 $V_{CCO} = 3.14$  to  $3.47$  V;  $R_{AVR} = 7.5$  k $\Omega$ ;  $R_{ER} = 62$  k $\Omega$ ;  $R_{MODIN} = 6.2$  k $\Omega$ ;  $R_{BIASIN} = 6.8$  k $\Omega$ ;  $R_{PWA} = 10$  k $\Omega$ ;  $R_{RREF} = 10$  k $\Omega$ ;  
 $R_{MAXMON} = 13$  k $\Omega$ ;  $R_{MAXOP} = 20$  k $\Omega$ ; positive currents flow into the IC; all voltages are referenced to ground; unless otherwise specified.

SYMBOL	PARAMETER	CONDITIONS	MIN.	TYP.	MAX.	UNIT
<b>Supplies: pins V<sub>CCA</sub>, V<sub>CCD</sub> and V<sub>CCO</sub></b>						
V <sub>CCA</sub>	analog supply voltage		3.14	3.3	3.47	V
V <sub>CCD</sub>	digital supply voltage		3.14	3.3	3.47	V
V <sub>CCO</sub>	RF output supply voltage	3.3 V laser supply	3.14	3.3	3.47	V
		5 V laser supply	4.75	5.0	5.25	V
I <sub>CCA</sub>	analog supply current		30	40	50	mA
I <sub>CCD</sub>	digital supply current		35	45	55	mA
I <sub>CCO</sub>	RF output supply current	pins LA and LAQ open-circuit				
		3.3 V laser supply	8	15	25	mA
		5 V laser supply	–	20	–	mA
P <sub>core</sub>	core power dissipation	core excluding output currents I <sub>o(LA)</sub> , I <sub>o(LAQ)</sub> and I <sub>BIAS</sub> ; PWA and retiming off	–	264	–	mW
P <sub>tot</sub>	total power dissipation	V <sub>BIAS</sub> = 3.3 V; I <sub>BIAS</sub> = 20 mA; I <sub>mod</sub> = 16 mA; note 1	330	400	500	mW
<b>Data and clock inputs: pins DIN and CIN</b>						
V <sub>i(p-p)</sub>	input voltage swing (peak-to-peak value)	V <sub>i(DIN)</sub> = (V <sub>CCD</sub> – 2 V) to V <sub>CCD</sub> ; V <sub>i(CIN)</sub> = (V <sub>CCD</sub> – 2 V) to V <sub>CCD</sub>	100	–	1000	mV
V <sub>int(cm)</sub>	internal common mode voltage	AC-coupled inputs	–	V <sub>CCD</sub> – 1.32	–	V
V <sub>IO</sub>	input offset voltage	note 2	–10	0	+10	mV
Z <sub>i(dif)</sub>	differential input impedance		80	100	125	$\Omega$
Z <sub>i(cm)</sub>	common mode input impedance		8	10	13	k $\Omega$
V <sub>i(CIN)(dis)</sub>	input voltage for disabled retiming	V <sub>CIN</sub> = V <sub>CINQ</sub>	–	–	0.3	V
<b>Monitor photodiode input: pin MON</b>						
V <sub>i(MON)</sub>	input voltage	I <sub>MON</sub> = 50 to 2500 $\mu$ A	0.9	1.1	1.3	V
Z <sub>i(MON)</sub>	input impedance	I <sub>MON</sub> = 50 to 2500 $\mu$ A	–	27	–	$\Omega$
<b>Extinction ratio setting for dual-loop control: pins MON and ER</b>						
ER <sub>min</sub>	low extinction ratio setting	dual-loop set-up; I <sub>ER</sub> > –30 $\mu$ A; note 3				
		linear scale	–	5	7	–
		dB scale	–	7	8.5	dB

## 30 Mbits/s up to 1.25 Gbits/s laser drivers

## TZA3047A; TZA3047B

SYMBOL	PARAMETER	CONDITIONS	MIN.	TYP.	MAX.	UNIT
ER <sub>max</sub>	high extinction ratio setting	dual-loop set-up; I <sub>ER</sub> < -10 μA; note 3				
		linear scale	13	15	-	-
		dB scale	11	11.8	-	dB
ER <sub>acc</sub>	relative accuracy of ER	temperature and V <sub>CCA</sub> variations; ER = 10; AVR = 550 μA	-10	-	+10	%
V <sub>ref(ER)</sub>	reference voltage on pin ER	I <sub>ER</sub> = -35 to -5 μA; C <sub>ER</sub> < 100 pF	1.15	1.20	1.25	V
I <sub>ER</sub>	current sink on pin ER		-35	-	-5	μA
<b>Average setting for dual-loop control and average loop control: pins MON and AVR</b>						
I <sub>av(MON)(low)</sub>	low average monitor current setting	I <sub>AVR</sub> > -280 μA				
		dual-loop (ER = 5) average loop (pin ER to GND)	-	-	150	μA μA
I <sub>av(MON)(max)</sub>	maximum average monitor current setting	I <sub>AVR</sub> = -15.0 μA				
		dual-loop (ER = 5) average loop (pin ER to GND)	1200	1300	-	μA μA
ΔI <sub>av(MON)</sub>	relative accuracy of average current on pin MON	temperature and V <sub>CCA</sub> variations; ER = 10; AVR = 550 μA	-10	-	+10	%
V <sub>ref(AVR)</sub>	reference voltage on pin AVR	I <sub>AVR</sub> = -250 to -15 μA; C <sub>AVR</sub> < 100 pF	1.15	1.20	1.25	V
I <sub>sink(AVR)</sub>	current sink on pin AVR		-280	-	-15	μA
<b>Control loop modulation output: pin MODOUT</b>						
I <sub>source(MODOUT)</sub>	source current	V <sub>MODOUT</sub> = 0.5 to 1.5 V; C <sub>MODOUT</sub> < 100 pF	-	-	-200	μA
I <sub>sink(MODOUT)</sub>	sink current	V <sub>MODOUT</sub> = 0.5 to 1.5 V; C <sub>MODOUT</sub> < 100 pF	200	-	-	μA
<b>Control loop bias output: pin BIASOUT</b>						
I <sub>source(BIASOUT)</sub>	source current	V <sub>BIASOUT</sub> = 0.5 to 1.5 V; C <sub>BIASOUT</sub> < 100 pF	-	-	-200	μA
I <sub>sink(BIASOUT)</sub>	sink current	V <sub>BIASOUT</sub> = 0.5 to 1.5 V; C <sub>BIASOUT</sub> < 100 pF	200	-	-	μA
<b>Bias current source: pins BIASIN and BIAS</b>						
g <sub>m(bias)</sub>	bias transconductance	V <sub>BIASIN</sub> = 0.5 to 1.5 V				
		V <sub>BIAS</sub> = V <sub>CCO</sub> = 3.3 V	90	110	125	mA/V
		V <sub>BIAS</sub> = 4.1 V; V <sub>CCO</sub> = 5.0 V	95	110	130	mA/V
I <sub>source(BIASIN)</sub>	source current at pin BIASIN	V <sub>BIASIN</sub> = 0.5 to 1.5 V	-110	-100	-95	μA
I <sub>BIAS(max)</sub>	maximum bias current	V <sub>BIASIN</sub> = 1.8 V	100	-	-	mA
I <sub>BIAS(min)</sub>	minimum bias current	V <sub>BIASIN</sub> = 0 to 0.4 V	-	0.2	0.4	mA
I <sub>BIAS(dis)</sub>	bias current at disable	V <sub>ENABLE</sub> < 0.8 V	-	-	30	μA

## 30 Mbits/s up to 1.25 Gbits/s laser drivers

## TZA3047A; TZA3047B

SYMBOL	PARAMETER	CONDITIONS	MIN.	TYP.	MAX.	UNIT
$V_{BIAS}$	output voltage on pin BIAS	normal operation				
		$V_{CCO} = 3.3\text{ V}$	0.4	–	3.6	V
		$V_{CCO} = 5\text{ V}$	0.8	–	4.1	V
<b>Modulation current source: pin MODIN</b>						
$g_{m(mod)}$	modulation transconductance	$V_{MODIN} = 0.5\text{ to }1.5\text{ V}$				
		$V_{LA} = V_{LAQ} = V_{CCO} = 3.3\text{ V}$	78	90	105	mA/V
		$V_{LA} = V_{LAQ} = V_{CCO} = 4.5\text{ V}$	80	95	110	mA/V
$I_{source(MODIN)}$	source current at pin MODIN	$V_{MODIN} = 0.5\text{ to }1.5\text{ V}$	–110	–100	–95	$\mu\text{A}$
<b>Modulation current outputs: pins LA</b>						
$I_{o(LA)(max)(on)}$	maximum laser modulation output current at LA on	$V_{MODIN} = 1.8\text{ V};$ $V_{LA} = V_{CCO} = 3.3\text{ V};$ note 4	100	–	–	mA
$I_{o(LA)(min)(on)}$	minimum laser modulation output current at LA on	$V_{MODIN} = 0\text{ to }0.4\text{ V};$ $V_{LA} = V_{CCO} = 3.3\text{ V};$ note 4	–	5	6	mA
$I_{o(LA)(min)(off)}$	minimum laser modulation output current at LA off	$V_{LA} = V_{CCO} = 3.3\text{ V};$ note 4	–	–	0.8	mA
		$V_{MODIN} = 0.5\text{ V}$ $V_{MODIN} = 1.5\text{ V}$	–	–	2	mA
$Z_{o(LA)}, Z_{o(LAQ)}$	output impedance pins LA and LAQ		80	100	125	$\Omega$
$I_{o(LA)(dis)},$ $I_{o(LAQ)(dis)}$	non-inverted and inverted laser modulation output current at disable	$V_{ENABLE} < 0.8\text{ V}$	–	–	200	$\mu\text{A}$
$V_{o(LA)min}$	minimum output voltage at pin LA	TZA3047A; $V_{CCO} = 3.3\text{ V}$	1.6	–	–	V
		TZA3047B; $V_{CCO} = 3.3\text{ V}$	1.2	–	–	V
		TZA3047B; $V_{CCO} = 5\text{ V}$	1.6	–	–	V
<b>Enable function: pin ENABLE</b>						
$V_{IL}$	LOW-level input voltage	bias and modulation currents disabled	–	–	0.8	V
$V_{IH}$	HIGH-level input voltage	bias and modulation currents enabled	2.0	–	–	V
$R_{pu(int)}$	internal pull-up resistance		16	20	30	k $\Omega$
<b>Alarm reset: pin ALRESET</b>						
$V_{IL}$	LOW-level input voltage	no reset	–	–	0.8	V
$V_{IH}$	HIGH-level input voltage	reset	2.0	–	–	V
$R_{pd(int)}$	internal pull-down resistance		7	10	15	k $\Omega$

## 30 Mbits/s up to 1.25 Gbits/s laser drivers

## TZA3047A; TZA3047B

SYMBOL	PARAMETER	CONDITIONS	MIN.	TYP.	MAX.	UNIT
<b>Alarm operating current: pins MAXOP and ALOP</b>						
$V_{\text{ref(MAXOP)}}$	reference voltage on pin MAXOP	$I_{\text{MAXOP}} = 10 \text{ to } 200 \mu\text{A}$	1.15	1.2	1.25	V
$N_{\text{MAXOP}}$	ratio of $I_{\text{oper(alarm)}}$ and $I_{\text{MAXOP}}$	$I_{\text{oper(alarm)}} = 7.5 \text{ to } 150 \text{ mA}$ $V_{\text{CCO}} = 3.3 \text{ V}$ $V_{\text{CCO}} = 5.0 \text{ V}$	700 750	800 850	900 950	
$V_{\text{D(ALOP)L}}$	drain voltage at active alarm	$I_{\text{ALOP}} = 500 \mu\text{A}$	0	–	0.4	V
<b>Alarm monitor current: pins MAXMON and ALMON</b>						
$V_{\text{ref(MAXMON)}}$	reference voltage on pin MAXMON	$I_{\text{MAXMON}} = 10 \text{ to } 200 \mu\text{A}$	1.15	1.2	1.25	V
$N_{\text{MAXMON}}$	ratio of $I_{\text{MON(alarm)}}$ and $I_{\text{MAXMON}}$	$I_{\text{MON(alarm)}} = 150 \text{ to } 3000 \mu\text{A}$	10	15	20	
$V_{\text{D(ALMON)L}}$	drain voltage at active alarm	$I_{\text{ALMON}} = 500 \mu\text{A}$	0	–	0.4	V
<b>Reference block: pins RREF and VTEMP</b>						
$V_{\text{RREF}}$	reference voltage	$R_{\text{RREF}} = 10 \text{ k}\Omega$ (1%); $C_{\text{RREF}} < 100 \text{ pF}$	1.15	1.20	1.25	V
$V_{\text{VTEMP}}$	temperature dependent voltage	$T_j = 25 \text{ }^\circ\text{C}$ ; $C_{\text{VTEMP}} < 2 \text{ nF}$ ; note 5	1.15	1.20	1.25	V
$\text{TC}_{\text{VTEMP}}$	temperature coefficient of $V_{\text{VTEMP}}$	$T_j = -25 \text{ to } +125 \text{ }^\circ\text{C}$ ; note 5	–	–2.2	–	mV/K
$I_{\text{source(VTEMP)}}$	source current of pin VTEMP		–	–	–1	mA
$I_{\text{sink(VTEMP)}}$	sink current of pin VTEMP		1	–	–	mA

**Notes**

- The total power dissipation  $P_{\text{tot}}$  is calculated with  $V_{\text{BIAS}} = V_{\text{CCO}} = 3.3 \text{ V}$  and  $I_{\text{BIAS}} = 20 \text{ mA}$ . In the application  $V_{\text{BIAS}}$  will be  $V_{\text{CCO}}$  minus the laser diode voltage which results in a lower total power dissipation.
- The specification of the offset voltage is guaranteed by design.
- Any (AVR, ER) setting needs to respect  $50 \mu\text{A} < I_{\text{MON}} < 2500 \mu\text{A}$ . Therefore, for large ER settings, minimum/maximum AVR cannot be reached.
- The relation between the sink current  $I_{\text{o(LA)}}$  and the modulation current  $I_{\text{mod}}$  is:  $I_{\text{o(LA)}} = I_{\text{mod}} \times \frac{100}{100 + Z_{\text{L(LA)}}$  where  $Z_{\text{L(LA)}}$  is the external load on pin LA. The voltage on pin MODIN programmes the modulation current  $I_{\text{mod}}$ . This current is divided between  $Z_{\text{L(LA)}}$  and the  $100 \Omega$  internal resistor connected to pins LA. When the modulation current is programmed to 100 mA, a typical  $Z_{\text{L(LA)}}$  of  $25 \Omega$  will result in an  $I_{\text{o(LA)}}$  current of 80 mA, while 20 mA flows via the internal resistor. This corresponds to a voltage swing of 2 V on the real application load.
- $V_{\text{VTEMP}} = 1.31 + \text{TC}_{\text{VTEMP}} \times T_j$  and  $T_j = T_{\text{amb}} + P_{\text{tot}} \times R_{\text{th(j-a)}}$ .

## 30 Mbits/s up to 1.25 Gbits/s laser drivers

## TZA3047A; TZA3047B

**11 AC CHARACTERISTICS**

$T_{amb} = -40$  to  $+85$  °C;  $R_{th(j-a)} = 35$  K/W;  $P_{tot} = 400$  mW;  $V_{CCA} = 3.14$  to  $3.47$  V;  $V_{CCD} = 3.14$  to  $3.47$  V;  
 $V_{CCO} = 3.14$  to  $3.47$  V;  $R_{AVR} = 7.5$  k $\Omega$ ;  $R_{ER} = 62$  k $\Omega$ ;  $R_{MODIN} = 6.2$  k $\Omega$ ;  $R_{BIASIN} = 6.8$  k $\Omega$ ;  $R_{PWA} = 10$  k $\Omega$ ;  $R_{RREF} = 10$  k $\Omega$ ;  
 $R_{MAXMON} = 13$  k $\Omega$ ;  $R_{MAXOP} = 20$  k $\Omega$ ; positive currents flow into the IC; all voltages are referenced to ground; unless otherwise specified.

SYMBOL	PARAMETER	CONDITIONS	MIN.	TYP.	MAX.	UNIT
<b>RF path</b>						
BR	bit rate		0.03	–	1.25	Gbits/s
$J_{LA(p-p)}$	jitter of pin LA output signal (peak-to-peak value)	$R_L = 25$ $\Omega$ ; note 1	–	–	30	ps
$t_r$	rise time of voltage on pin LA	20% to 80%; $R_L = 25$ $\Omega$ ; note 2	–	120	150	ps
$t_f$	fall time of voltage on pin LA	80% to 20%; $R_L = 25$ $\Omega$ ; note 2	–	120	150	ps
$t_{su(D)}$	data input set-up time		60	–	–	ps
$t_{h(D)}$	data input hold time		60	–	–	ps
$t_{en(start)}$	start-up time at enable	direct current setting	–	–	1	$\mu$ s
<b>Current control</b>						
$t_{cint}$	internal time constant	dual-loop control operating currents fully settled	30	–	–	ms
<b>Pulse width adjustment</b>						
$t_{PWA(min)}$	minimum pulse width adjustment on pins LA	$R_{PWA} = 6.7$ k $\Omega$ ; $C_{PWA} < 100$ pF	–	–100	–	ps
$t_{PWA}$	pulse width adjustment on pins LA	$R_{PWA} = 10$ k $\Omega$ ; $C_{PWA} < 100$ pF	–	0	–	ps
$t_{PWA(max)}$	maximum pulse width adjustment on pins LA	$R_{PWA} = 20$ k $\Omega$ ; $C_{PWA} < 100$ pF	–	100	–	ps

**Notes**

1. The output jitter specification is guaranteed by design.
2. For high modulation current,  $t_r$  and  $t_f$  are impacted by total inductance between the LA pins and the laser connection.

30 Mbits/s up to 1.25 Gbits/s laser drivers

TZA3047A; TZA3047B

12 APPLICATION INFORMATION

12.1 Design equations

12.1.1 BIAS AND MODULATION CURRENTS

The bias and modulation currents are determined by the voltages on pins BIASIN and MODIN. These voltages are applied by the BIASOUT and MODOUT pins for dual-loop control. For average loop control the BIASIN voltage is applied by the BIASOUT pin and the MODIN voltage is applied by an external voltage source or an external resistor  $R_{MODIN}$ .

For direct setting of bias and the modulation current, the BIASIN and MODIN voltages have to be applied by external voltage sources or by  $R_{BIASIN}$  and  $R_{MODIN}$  external resistors connected on BIASIN and MODIN pins:

$$I_{BIAS} = (R_{BIASIN} \times 100 \mu A - 0.5 V) \times g_{m(bias)} [mA]$$

$$I_{mod} = (R_{MODIN} \times 100 \mu A - 0.5 V) \times g_{m(mod)} + 5 [mA]$$

The bias and modulation current sources operate with an input voltage range from 0.5 to 1.5 V. The output current is at its minimum level for an input voltage below 0.4 V; see Figs 3 and 4.

The bias and modulation current sources are temperature compensated and the adjusted current level remains stable over the temperature range.

The bias and modulation currents increase with increasing resistor values for  $R_{BIASIN}$  and  $R_{MODIN}$  respectively, this allows resistor tuning to start at a minimum current level.

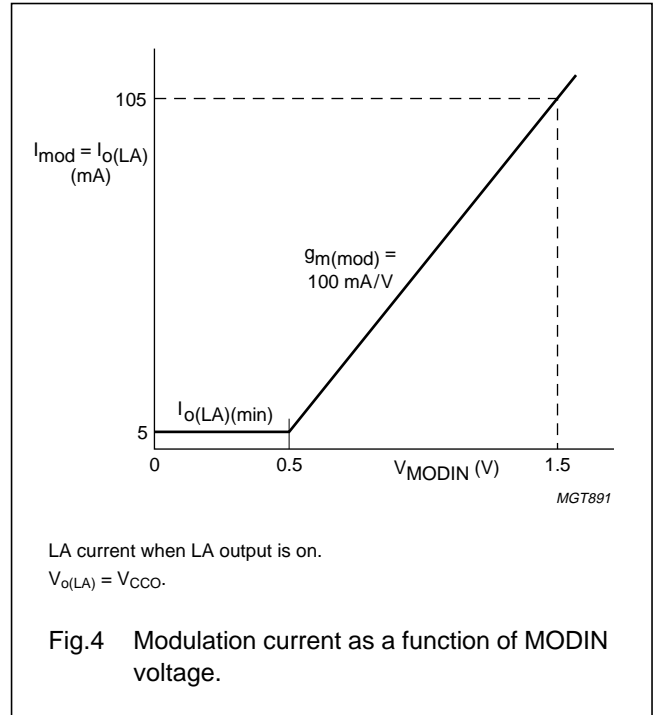
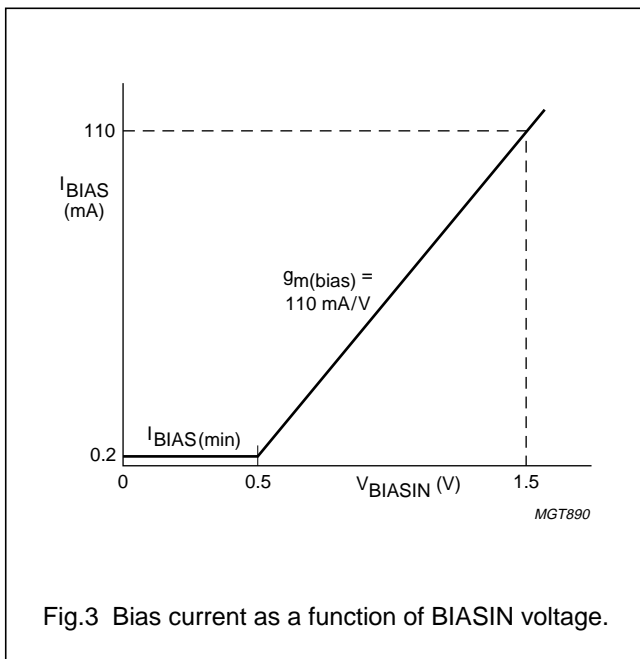

12.1.2 AVERAGE MONITOR CURRENT AND EXTINCTION RATIO

The average monitor current  $I_{av(MON)}$  in dual-loop or average loop operation is determined by the source current ( $I_{AVR}$ ) of the AVR pin. The current can be sunk by an external current source or by an external resistor ( $R_{AVR}$ ) connected to ground:

$$I_{av(MON)} = 1580 - 5.26 \times I_{AVR} = 1580 - 5.26 \times \frac{V_{AVR}}{R_{AVR}} [\mu A]$$

The extinction ratio in dual-loop operation is determined by the source current ( $I_{ER}$ ) of the ER pin. The current can be sunk by an external current source or by an external resistor ( $R_{ER}$ ) connected to ground:

$$ER = 20 - \frac{I_{ER}}{2 \mu A} = 20 - \frac{1}{2 \mu A} \times \frac{V_{ER}}{R_{ER}}$$

The average monitor current and the extinction ratio as a function of the  $I_{AVR}$  and  $I_{ER}$  current are illustrated in Fig.5.

The average monitor current increases with a decreasing  $I_{AVR}$  or increasing  $R_{AVR}$ , this allows resistor tuning of  $R_{AVR}$  to start at minimum  $I_{AVR}$  current level.

The formulas used to program AVR and ER are valid for typical conditions; tuning is necessary to achieve good absolute accuracy of AVR and ER values.

30 Mbits/s up to 1.25 Gbits/s laser drivers

TZA3047A; TZA3047B

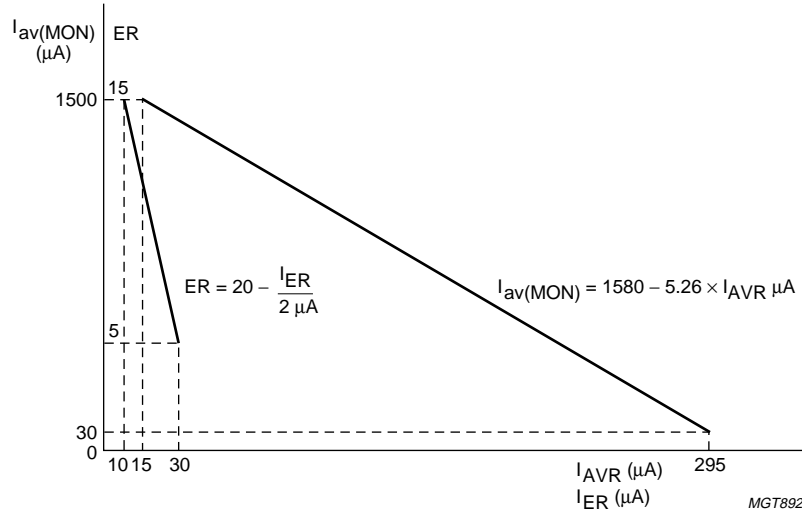

Fig.5 Average monitor current and extinction ratio as a function of  $I_{AVR}$  and  $I_{ER}$ .

12.1.3 DUAL-LOOP CONTROL

The dual-loop control measures the monitor current ( $I_{MON}$ ) corresponding with an optical 'one' level and the  $I_{MON}$  corresponding with the optical 'zero' level. The measured  $I_{MON(one)}$  and  $I_{MON(zero)}$  are compared with the average monitor current setting and the extinction ratio setting according to:

$$I_{av(MON)} = \frac{I_{MON(one)} + I_{MON(zero)}}{2}$$

$$ER = \frac{I_{MON(one)}}{I_{MON(zero)}}$$

The dual-loop controls the bias and the modulation current for obtaining the  $I_{MON(one)}$  and  $I_{MON(zero)}$  current levels which correspond with the programmed AVR and ER settings.

Performance of the dual-loop for high data-rate is linked to the quality of the incoming IMON signal: a high performance interconnection between monitor photodiode and MON input is requested for maximum data rate applications (1.25 Gbits/s).

The operational area of the dual-loop and the control area of the monitor input current must respect the following equations:

$$50 \mu A < I_{MON(zero)} < 500 \mu A$$

$$250 \mu A < I_{MON(one)} < 2500 \mu A$$

Stability of ER and AVR settings are guaranteed over a range of temperature and supply voltage variations.



30 Mbits/s up to 1.25 Gbits/s laser drivers

TZA3047A; TZA3047B

12.1.4 ALARM OPERATING CURRENT

The alarm threshold  $I_{oper(alarm)}$  on the operating current is determined by the source current  $I_{MAXOP}$  of the MAXOP pin. The current range for  $I_{MAXOP}$  is from 10 to 200  $\mu$ A which corresponds with an  $I_{oper(alarm)}$  from 7.5 to 150 mA. The  $I_{MAXOP}$  current can be sunk by an external current source or by connecting  $R_{MAXOP}$  to ground:

$$I_{oper(alarm)} = N_{MAXOP} \times \frac{V_{MAXOP}}{R_{MAXOP}}$$

The operating current equals the bias current for an AC-coupled laser application and equals the bias current plus half of the modulation current for the DC-coupled laser application:

$$I_{oper(TZA3047A)} = I_{BIAS}$$

$$I_{oper(TZA3047B)} = I_{BIAS} + \frac{I_{mod}}{2}$$

12.1.5 ALARM MONITOR CURRENT

The alarm threshold  $I_{MON(alarm)}$  on the monitor current is determined by the source current  $I_{MAXMON}$  of the MAXMON pin. The current range for  $I_{MAXMON}$  is from 10 to 200  $\mu$ A which corresponds with an  $I_{MON(alarm)}$  from 150 to 3000  $\mu$ A. The  $I_{MAXMON}$  current can be sunk by an external current source or by connecting  $R_{MAXMON}$  to ground:

$$I_{MON(alarm)} = N_{MAXMON} \times \frac{V_{MAXMON}}{R_{MAXMON}}$$

12.1.6 PULSE WIDTH ADJUSTMENT

The pulse width adjustment time is determined by the value of resistor  $R_{PWA}$ , as shown below.

$$t_{PWA} = 200 \times \frac{R_{PWA} - 10 \text{ k}\Omega}{R_{PWA}} \text{ [ps]}$$

The  $t_{PWA}$  range is from -100 to +100 ps which corresponds with a  $R_{PWA}$  range between a minimum resistance of 6.7 k $\Omega$  and a maximum resistance of 20 k $\Omega$ . The PWA function is disabled when the PWA input is short-circuited to ground;  $t_{PWA}$  equals 0 ps for a disabled PWA function.

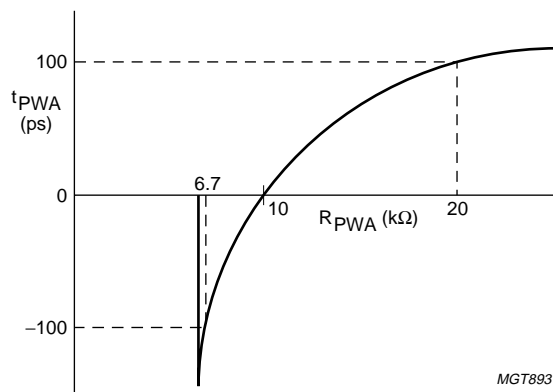

Fig.6 Pulse width adjustment.

30 Mbits/s up to 1.25 Gbits/s laser drivers

TZA3047A; TZA3047B

12.2 TZA3047A with dual-loop control

A simplified application using the TZA3047A with dual-loop control and with an AC-coupled laser at 3.3 V laser voltage is illustrated in Fig.7. The average power level and the extinction ratio are determined by the resistors  $R_{AVR}$  and  $R_{ER}$ . The MODOUT and BIASOUT outputs are connected to the MODIN and the BIASIN inputs respectively. The alarm threshold on the operating current is made temperature dependent with resistor  $R_{VTEMP}$  connected between VTEMP and MAXOP. This alarm detects the end of life of the laser.

$$I_{oper(alarm)} = N_{MAXOP} \times \left( \frac{V_{MAXOP}}{R_{MAXOP}} - \frac{TC_{VTEMP} \times (T_j - 25 \text{ }^\circ\text{C})}{R_{VTEMP}} \right)$$

The resistor  $R_{PWA}$  enables pulse width adjustment for optimizing the eye diagram.

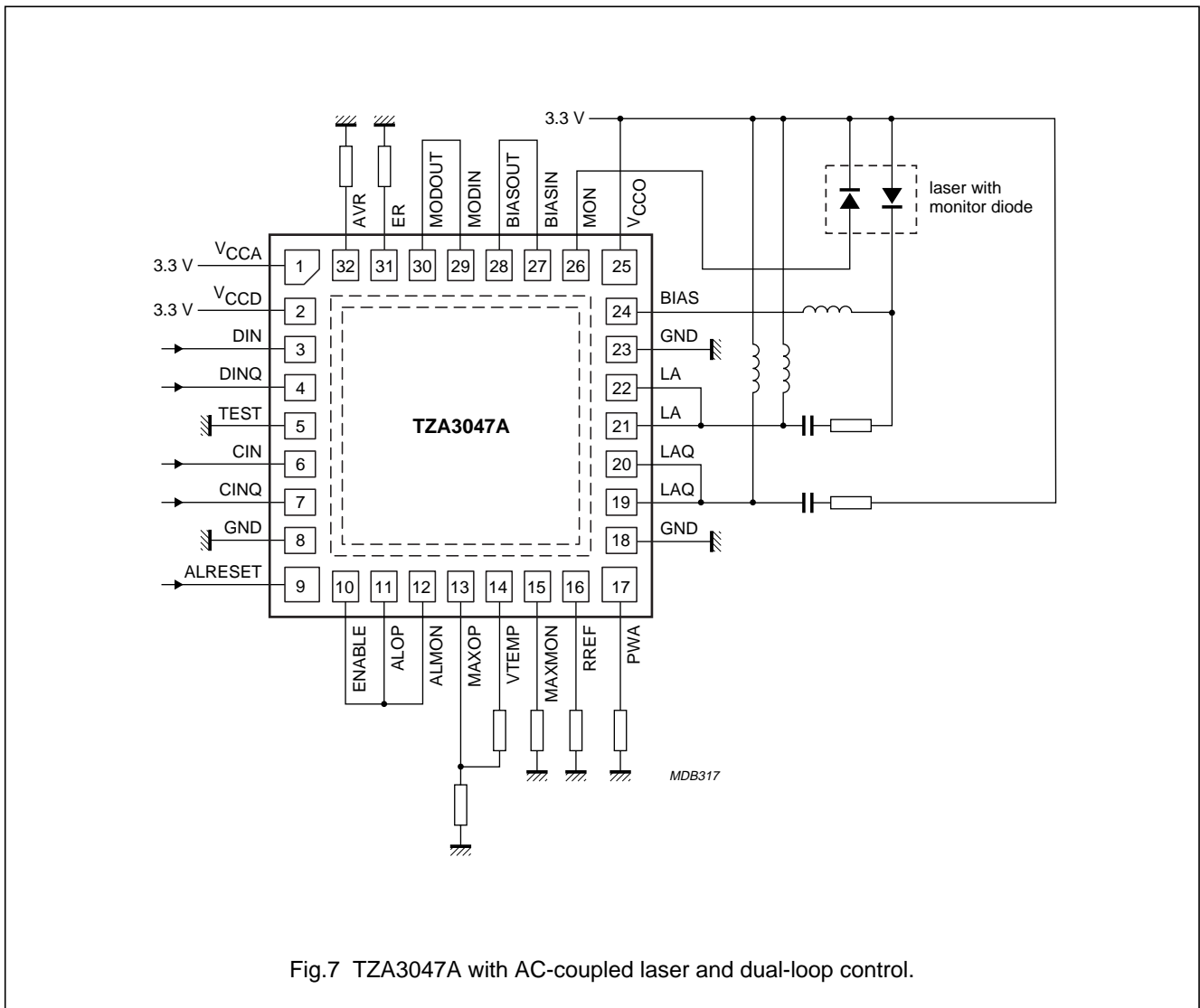

Fig.7 TZA3047A with AC-coupled laser and dual-loop control.

30 Mbits/s up to 1.25 Gbits/s laser drivers

TZA3047A; TZA3047B

12.3 TZA3047B with dual-loop control

A simplified application using the TZA3047B with dual-loop control and with a DC-coupled laser at 3.3 V or 5 V laser voltage is illustrated in Fig.8. The average power level and the extinction ratio are determined by the resistors  $R_{AVR}$  and  $R_{ER}$ . The MODOUT and BIASOUT outputs are connected to the MODIN and the BIASIN inputs respectively.

The open-drain outputs ALOP and ALMON are short-circuited with pin ENABLE causing an active alarm to disable the bias and modulation current sources. The ALRESET input will reset the alarm latches and enable normal operation.

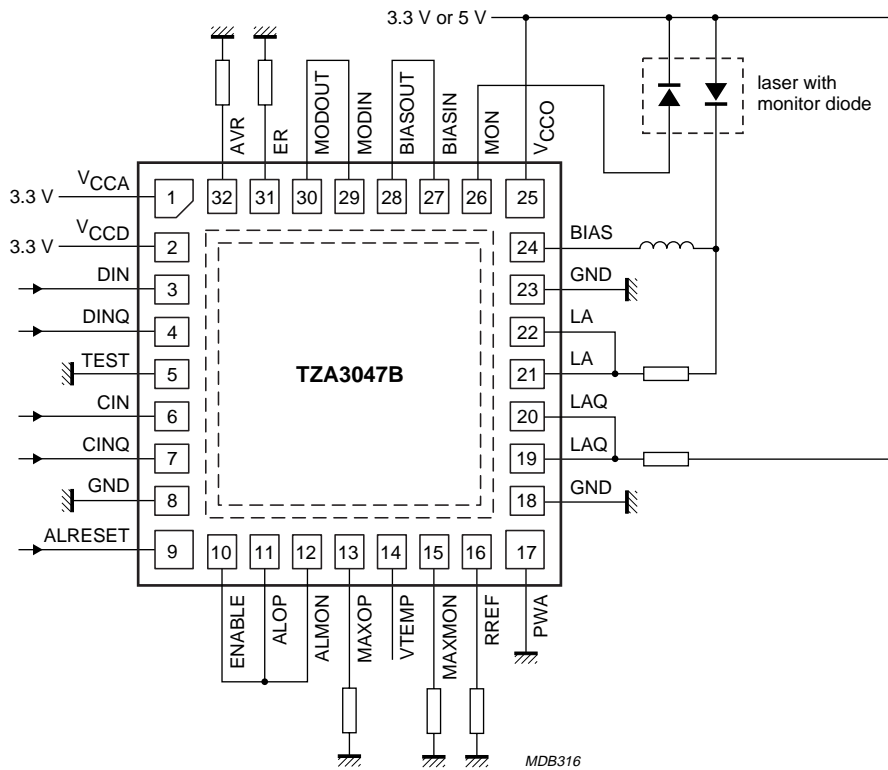

Fig.8 TZA3047B with DC-coupled laser and dual-loop control.

30 Mbits/s up to 1.25 Gbits/s laser drivers

TZA3047A; TZA3047B

12.4 TZA3047B with average loop control

A simplified application using the TZA3047B with average loop control and a DC-coupled laser at 3.3 or 5 V laser voltage is illustrated in Fig.9. The ER pin is short-circuited to ground for the average loop control. The average power level is determined by the resistor  $R_{AVR}$ . The average loop controls the bias current and the BIASOUT output is connected to the BIASIN input. The modulation current is determined by the MODIN input voltage which is generated by the resistor  $R_{MODIN}$  and the 100  $\mu$ A source current of the MODIN pin.

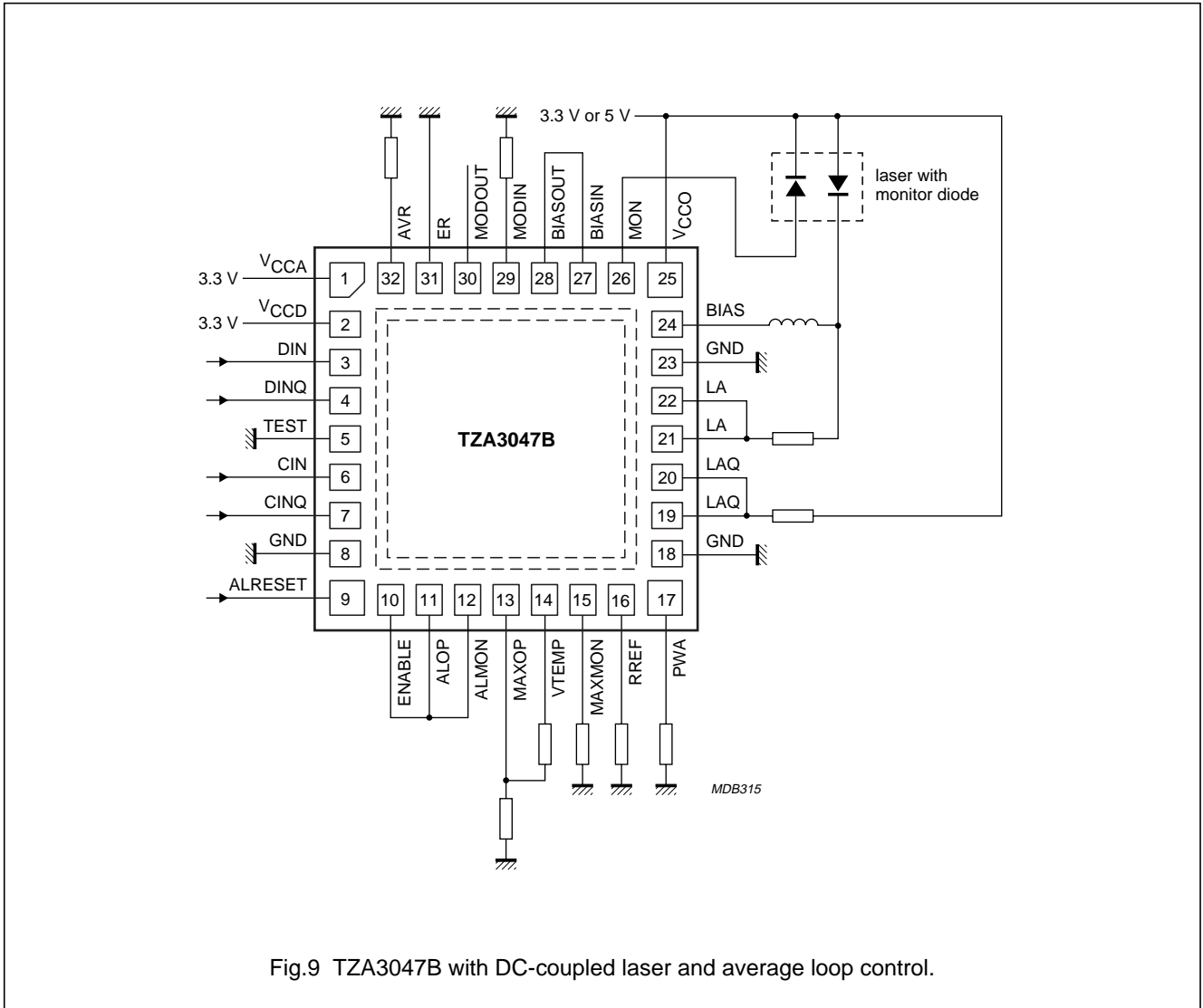

Fig.9 TZA3047B with DC-coupled laser and average loop control.

## 30 Mbits/s up to 1.25 Gbits/s laser drivers

## TZA3047A; TZA3047B

## 13 BONDING PAD LOCATIONS

SYMBOL	PAD <sup>(2)(3)</sup>	COORDINATES <sup>(1)</sup>	
		x	y
V <sub>CCA</sub>	1	-1123.9	+1029.3
V <sub>CCA</sub>	2	-1123.9	+949.3
V <sub>CCD</sub>	3	-1123.9	+844.3
V <sub>CCD</sub>	4	-1123.9	+764.3
DIN	5	-1124.0	+604.3
DINQ	6	-1124.9	+393.3
GNDRF	7	-1123.9	+244.5
GNDRF	8	-1123.9	+139.4
GNDRF	9	-1123.9	+4.7
GNDRF	10	-1123.9	-100.3
TEST	11	-1123.4	-253.4
CIN	12	-1123.9	-441.2
CINQ	13	-1123.9	-697.1
GNDESD	14	-1123.9	-850.8
ALRESET	15	-1123.9	-991.4
ENABLE	16	-829.8	-1123.7
GNDDFT	17	-665.6	-1124.0
ALOP	18	-504.9	-1124
ALMON	19	-267.6	-1124.3
i.c.	20 <sup>(4)</sup>	-221.5	-344.4
MAXOP	21	-98.5	-1124.3
i.c.	22 <sup>(4)</sup>	-48.6	-368.4
VTEMP	23	+294.0	-1124.2
MAXMON	24	+466.9	-1124.2
RREF	25	+694.9	-1124.0
GNDRF	26	+860.3	-1124.0
PWA	27	+1098.9	-979.4
GNDO	28	+1099.0	-829.7
LAQ	29	+1099.0	-691.2
LAQ	30	+1099.0	-611.2
LAQ	31	+1099.0	-506.4
LAQ	32	+1099.0	-426.4
GNDO	33	+1099.8	-247.0
i.c.	34 <sup>(4)</sup>	+839.0	-194.4
GNDO	35	+1099.8	-142.0
GNDO	36	+1099.8	-36.8
LA	37	1099.1	105.4
i.c.	38 <sup>(4)</sup>	839.0	179.6

SYMBOL	PAD <sup>(2)(3)</sup>	COORDINATES <sup>(1)</sup>	
		x	y
LA	39	1099.1	185.4
LA	40	1099.1	290.5
LA	41	1099.1	370.5
GNDO	42	1099.1	670.8
BIAS	43	1099.0	804.8
V <sub>CCO</sub>	44	1099.0	944.4
V <sub>CCO</sub>	45	1099.0	1024.4
ACDC	46	942.5	1124.3
GNDESD	47	765.0	1123.8
MON	48	602.1	1123.7
BIASIN	49	431.7	1123.8
BIASOUT	50	267.6	1123.8
GNDCCB	51	100.8	1123.8
MODIN	52	-82.7	+1123.8
GNDCCB	53	-241.1	+1123.8
i.c.	54 <sup>(4)</sup>	-274.4	+954.4
MODOUT	55	-487.2	+1123.8
ER	56	-645.6	+1123.8
AVR	57	-802.8	+1123.8

## Notes

1. All coordinates are referenced (in  $\mu\text{m}$ ) to the centre of the die.
2. All GND connections should be used.
3. Recommended order of bonding: all GND first, then V<sub>CCA</sub>, V<sub>CCD</sub> and V<sub>CCO</sub> supplies and finally the input and output pins.
4. Pad is internally connected, do not use.

30 Mbits/s up to 1.25 Gbits/s laser drivers

TZA3047A; TZA3047B

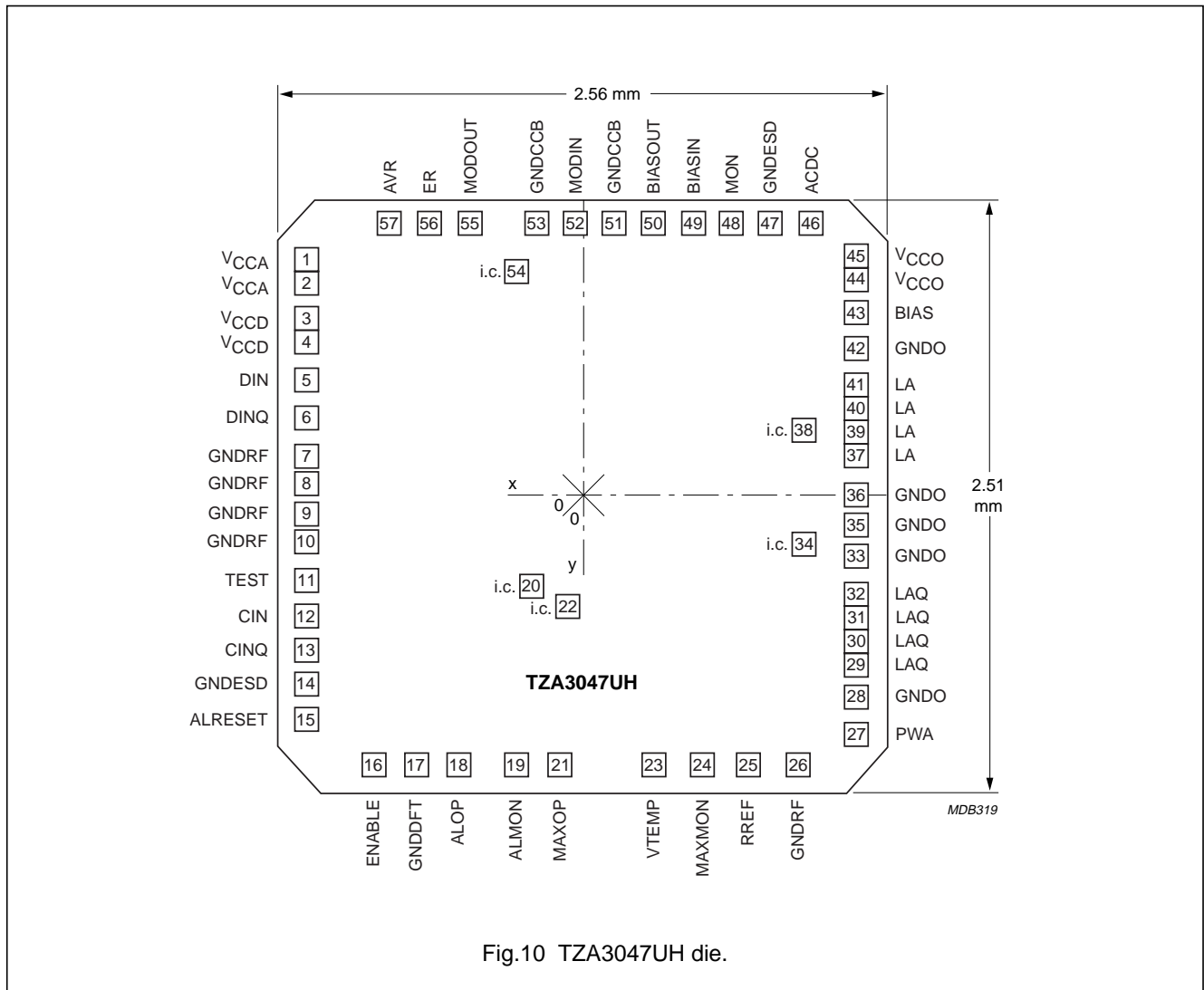

Fig.10 TZA3047UH die.

Table 1 Physical characteristics of the bare die

PARAMETER	VALUE
Glass passivation	0.3 μm PSG (PhosphoSilicate Glass) on top of 0.8 μm of silicon nitride
Bonding pad dimension	minimum dimension of exposed metallization is 80 × 80 μm (pad size = 90 × 90 μm)
Metallization	2.8 μm AlCu
Thickness	380 μm nominal
Size	2.560 × 2.510 mm (6.43 mm <sup>2</sup> )
Backing	silicon; electrically connected to GND potential through substrate contacts
Attach temperature	<440 °C; recommended die attachment is by gluing
Attach time	<15 s

30 Mbits/s up to 1.25 Gbits/s laser drivers

TZA3047A; TZA3047B

14 PACKAGE OUTLINE

HBCC32: plastic thermal enhanced bottom chip carrier; 32 terminals; body 5 x 5 x 0.65 mm

SOT560-1

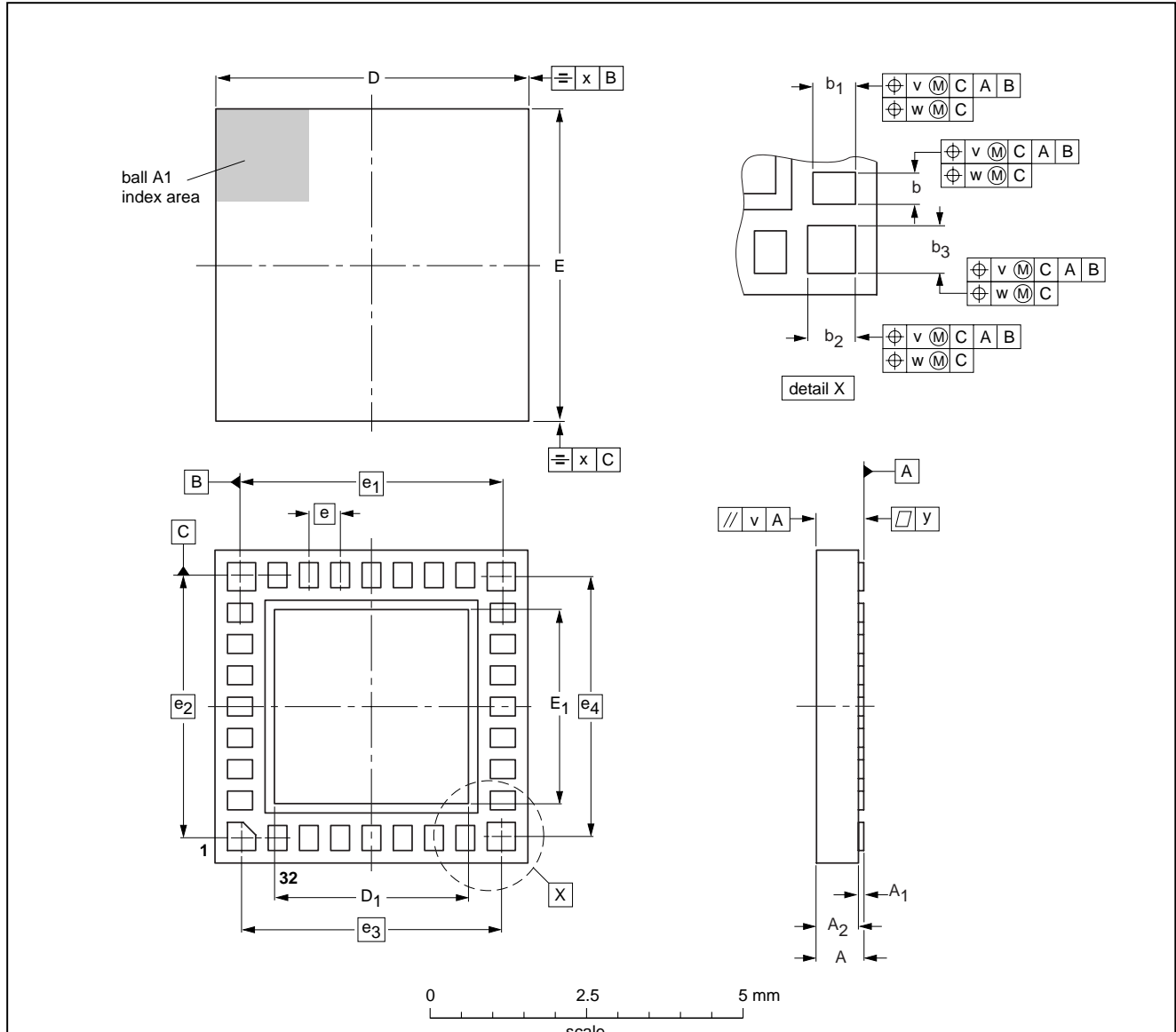

DIMENSIONS (mm are the original dimensions)

UNIT	A max.	A <sub>1</sub>	A <sub>2</sub>	b	b <sub>1</sub>	b <sub>2</sub>	b <sub>3</sub>	D	D <sub>1</sub>	E	E <sub>1</sub>	e	e <sub>1</sub>	e <sub>2</sub>	e <sub>3</sub>	e <sub>4</sub>	v	w	x	y
mm	0.8	0.10 0.05	0.7 0.6	0.35 0.20	0.5 0.3	0.50 0.35	0.50 0.35	5.1 4.9	3.2 3.0	5.1 4.9	3.2 3.0	0.5	4.2	4.2	4.15	4.15	0.2	0.15	0.15	0.05

OUTLINE VERSION	REFERENCES				EUROPEAN PROJECTION	ISSUE DATE
	IEC	JEDEC	JEITA			
SOT560-1		MO-217				00-02-01 03-03-12

## 30 Mbits/s up to 1.25 Gbits/s laser drivers

## TZA3047A; TZA3047B

**15 SOLDERING****15.1 Introduction to soldering surface mount packages**

This text gives a very brief insight to a complex technology. A more in-depth account of soldering ICs can be found in our *"Data Handbook IC26; Integrated Circuit Packages"* (document order number 9398 652 90011).

There is no soldering method that is ideal for all surface mount IC packages. Wave soldering can still be used for certain surface mount ICs, but it is not suitable for fine pitch SMDs. In these situations reflow soldering is recommended.

**15.2 Reflow soldering**

Reflow soldering requires solder paste (a suspension of fine solder particles, flux and binding agent) to be applied to the printed-circuit board by screen printing, stencilling or pressure-syringe dispensing before package placement.

Several methods exist for reflowing; for example, convection or convection/infrared heating in a conveyor type oven. Throughput times (preheating, soldering and cooling) vary between 100 and 200 seconds depending on heating method.

Typical reflow peak temperatures range from 215 to 250 °C. The top-surface temperature of the packages should preferably be kept:

- below 220 °C for all the BGA packages and packages with a thickness  $\geq 2.5$  mm and packages with a thickness  $< 2.5$  mm and a volume  $\geq 350$  mm<sup>3</sup> so called thick/large packages
- below 235 °C for packages with a thickness  $< 2.5$  mm and a volume  $< 350$  mm<sup>3</sup> so called small/thin packages.

**15.3 Wave soldering**

Conventional single wave soldering is not recommended for surface mount devices (SMDs) or printed-circuit boards with a high component density, as solder bridging and non-wetting can present major problems.

To overcome these problems the double-wave soldering method was specifically developed.

If wave soldering is used the following conditions must be observed for optimal results:

- Use a double-wave soldering method comprising a turbulent wave with high upward pressure followed by a smooth laminar wave.
- For packages with leads on two sides and a pitch (e):
  - larger than or equal to 1.27 mm, the footprint longitudinal axis is **preferred** to be parallel to the transport direction of the printed-circuit board;
  - smaller than 1.27 mm, the footprint longitudinal axis **must** be parallel to the transport direction of the printed-circuit board.

The footprint must incorporate solder thieves at the downstream end.

- For packages with leads on four sides, the footprint must be placed at a 45° angle to the transport direction of the printed-circuit board. The footprint must incorporate solder thieves downstream and at the side corners.

During placement and before soldering, the package must be fixed with a droplet of adhesive. The adhesive can be applied by screen printing, pin transfer or syringe dispensing. The package can be soldered after the adhesive is cured.

Typical dwell time is 4 seconds at 250 °C.

A mildly-activated flux will eliminate the need for removal of corrosive residues in most applications.

**15.4 Manual soldering**

Fix the component by first soldering two diagonally-opposite end leads. Use a low voltage (24 V or less) soldering iron applied to the flat part of the lead. Contact time must be limited to 10 seconds at up to 300 °C.

When using a dedicated tool, all other leads can be soldered in one operation within 2 to 5 seconds between 270 and 320 °C.



## 30 Mbits/s up to 1.25 Gbits/s laser drivers

## TZA3047A; TZA3047B

**15.5 Suitability of surface mount IC packages for wave and reflow soldering methods**

PACKAGE <sup>(1)</sup>	SOLDERING METHOD	
	WAVE	REFLOW <sup>(2)</sup>
BGA, LBGA, LFBGA, SQFP, TFBGA, VFBGA	not suitable	suitable
DHVQFN, HBCC, HBGA, HLQFP, HSQFP, HSOP, HTQFP, HTSSOP, HVQFN, HVSON, SMS	not suitable <sup>(3)</sup>	suitable
PLCC <sup>(4)</sup> , SO, SOJ	suitable	suitable
LQFP, QFP, TQFP	not recommended <sup>(4)(5)</sup>	suitable
SSOP, TSSOP, VSO, VSSOP	not recommended <sup>(6)</sup>	suitable

**Notes**

1. For more detailed information on the BGA packages refer to the “(LF)BGA Application Note” (AN01026); order a copy from your Philips Semiconductors sales office.
2. All surface mount (SMD) packages are moisture sensitive. Depending upon the moisture content, the maximum temperature (with respect to time) and body size of the package, there is a risk that internal or external package cracks may occur due to vaporization of the moisture in them (the so called popcorn effect). For details, refer to the Drypack information in the “Data Handbook IC26; Integrated Circuit Packages; Section: Packing Methods”.
3. These packages are not suitable for wave soldering. On versions with the heatsink on the bottom side, the solder cannot penetrate between the printed-circuit board and the heatsink. On versions with the heatsink on the top side, the solder might be deposited on the heatsink surface.
4. If wave soldering is considered, then the package must be placed at a 45° angle to the solder wave direction. The package footprint must incorporate solder thieves downstream and at the side corners.
5. Wave soldering is suitable for LQFP, TQFP and QFP packages with a pitch (e) larger than 0.8 mm; it is definitely not suitable for packages with a pitch (e) equal to or smaller than 0.65 mm.
6. Wave soldering is suitable for SSOP, TSSOP, VSO and VSSOP packages with a pitch (e) equal to or larger than 0.65 mm; it is definitely not suitable for packages with a pitch (e) equal to or smaller than 0.5 mm.

## 30 Mbits/s up to 1.25 Gbits/s laser drivers

## TZA3047A; TZA3047B

## 16 DATA SHEET STATUS

LEVEL	DATA SHEET STATUS <sup>(1)</sup>	PRODUCT STATUS <sup>(2)(3)</sup>	DEFINITION
I	Objective data	Development	This data sheet contains data from the objective specification for product development. Philips Semiconductors reserves the right to change the specification in any manner without notice.
II	Preliminary data	Qualification	This data sheet contains data from the preliminary specification. Supplementary data will be published at a later date. Philips Semiconductors reserves the right to change the specification without notice, in order to improve the design and supply the best possible product.
III	Product data	Production	This data sheet contains data from the product specification. Philips Semiconductors reserves the right to make changes at any time in order to improve the design, manufacturing and supply. Relevant changes will be communicated via a Customer Product/Process Change Notification (CPCN).

## Notes

1. Please consult the most recently issued data sheet before initiating or completing a design.
2. The product status of the device(s) described in this data sheet may have changed since this data sheet was published. The latest information is available on the Internet at URL <http://www.semiconductors.philips.com>.
3. For data sheets describing multiple type numbers, the highest-level product status determines the data sheet status.

## 17 DEFINITIONS

**Short-form specification** — The data in a short-form specification is extracted from a full data sheet with the same type number and title. For detailed information see the relevant data sheet or data handbook.

**Limiting values definition** — Limiting values given are in accordance with the Absolute Maximum Rating System (IEC 60134). Stress above one or more of the limiting values may cause permanent damage to the device. These are stress ratings only and operation of the device at these or at any other conditions above those given in the Characteristics sections of the specification is not implied. Exposure to limiting values for extended periods may affect device reliability.

**Application information** — Applications that are described herein for any of these products are for illustrative purposes only. Philips Semiconductors make no representation or warranty that such applications will be suitable for the specified use without further testing or modification.

## 18 DISCLAIMERS

**Life support applications** — These products are not designed for use in life support appliances, devices, or systems where malfunction of these products can reasonably be expected to result in personal injury. Philips Semiconductors customers using or selling these products for use in such applications do so at their own risk and agree to fully indemnify Philips Semiconductors for any damages resulting from such application.

**Right to make changes** — Philips Semiconductors reserves the right to make changes in the products - including circuits, standard cells, and/or software - described or contained herein in order to improve design and/or performance. When the product is in full production (status 'Production'), relevant changes will be communicated via a Customer Product/Process Change Notification (CPCN). Philips Semiconductors assumes no responsibility or liability for the use of any of these products, conveys no licence or title under any patent, copyright, or mask work right to these products, and makes no representations or warranties that these products are free from patent, copyright, or mask work right infringement, unless otherwise specified.

---

**30 Mbits/s up to 1.25 Gbits/s laser drivers****TZA3047A; TZA3047B**

---

**Bare die** — All die are tested and are guaranteed to comply with all data sheet limits up to the point of wafer sawing for a period of ninety (90) days from the date of Philips' delivery. If there are data sheet limits not guaranteed, these will be separately indicated in the data sheet. There are no post packing tests performed on individual die or wafer. Philips Semiconductors has no control of third party procedures in the sawing, handling, packing or assembly of the die. Accordingly, Philips Semiconductors assumes no liability for device functionality or performance of the die or systems after third party sawing, handling, packing or assembly of the die. It is the responsibility of the customer to test and qualify their application in which the die is used.

# ***Philips Semiconductors – a worldwide company***

## **Contact information**

For additional information please visit <http://www.semiconductors.philips.com>. Fax: +31 40 27 24825

For sales offices addresses send e-mail to: [sales.addresses@www.semiconductors.philips.com](mailto:sales.addresses@www.semiconductors.philips.com).

© Koninklijke Philips Electronics N.V. 2003

SCA75

All rights are reserved. Reproduction in whole or in part is prohibited without the prior written consent of the copyright owner.

The information presented in this document does not form part of any quotation or contract, is believed to be accurate and reliable and may be changed without notice. No liability will be accepted by the publisher for any consequence of its use. Publication thereof does not convey nor imply any license under patent- or other industrial or intellectual property rights.

Printed in The Netherlands

403510/01/pp28

Date of release: 2003 Jun 05

Document order number: 9397 750 11277

*Let's make things better.*

**Philips  
Semiconductors**



**PHILIPS**