



MICROCHIP

**EMC1182
Temperature Sensor
Evaluation Board
User's Guide**

Note the following details of the code protection feature on Microchip devices:

- Microchip products meet the specification contained in their particular Microchip Data Sheet.
- Microchip believes that its family of products is one of the most secure families of its kind on the market today, when used in the intended manner and under normal conditions.
- There are dishonest and possibly illegal methods used to breach the code protection feature. All of these methods, to our knowledge, require using the Microchip products in a manner outside the operating specifications contained in Microchip's Data Sheets. Most likely, the person doing so is engaged in theft of intellectual property.
- Microchip is willing to work with the customer who is concerned about the integrity of their code.
- Neither Microchip nor any other semiconductor manufacturer can guarantee the security of their code. Code protection does not mean that we are guaranteeing the product as "unbreakable."

Code protection is constantly evolving. We at Microchip are committed to continuously improving the code protection features of our products. Attempts to break Microchip's code protection feature may be a violation of the Digital Millennium Copyright Act. If such acts allow unauthorized access to your software or other copyrighted work, you may have a right to sue for relief under that Act.

Information contained in this publication regarding device applications and the like is provided only for your convenience and may be superseded by updates. It is your responsibility to ensure that your application meets with your specifications. MICROCHIP MAKES NO REPRESENTATIONS OR WARRANTIES OF ANY KIND WHETHER EXPRESS OR IMPLIED, WRITTEN OR ORAL, STATUTORY OR OTHERWISE, RELATED TO THE INFORMATION, INCLUDING BUT NOT LIMITED TO ITS CONDITION, QUALITY, PERFORMANCE, MERCHANTABILITY OR FITNESS FOR PURPOSE. Microchip disclaims all liability arising from this information and its use. Use of Microchip devices in life support and/or safety applications is entirely at the buyer's risk, and the buyer agrees to defend, indemnify and hold harmless Microchip from any and all damages, claims, suits, or expenses resulting from such use. No licenses are conveyed, implicitly or otherwise, under any Microchip intellectual property rights.

Trademarks

The Microchip name and logo, the Microchip logo, dsPIC, FlashFlex, KEELOQ, KEELOQ logo, MPLAB, PIC, PICmicro, PICSTART, PIC³² logo, rPIC, SST, SST Logo, SuperFlash and UNI/O are registered trademarks of Microchip Technology Incorporated in the U.S.A. and other countries.

FilterLab, Hampshire, HI-TECH C, Linear Active Thermistor, MTP, SEEVAL and The Embedded Control Solutions Company are registered trademarks of Microchip Technology Incorporated in the U.S.A.

Silicon Storage Technology is a registered trademark of Microchip Technology Inc. in other countries.

Analog-for-the-Digital Age, Application Maestro, BodyCom, chipKIT, chipKIT logo, CodeGuard, dsPICDEM, dsPICDEM.net, dsPICworks, dsSPEAK, ECAN, ECONOMONITOR, FanSense, HI-TIDE, In-Circuit Serial Programming, ICSP, Mindi, MiWi, MPASM, MPF, MPLAB Certified logo, MPLIB, MPLINK, mTouch, Omniscent Code Generation, PICC, PICC-18, PICDEM, PICDEM.net, PICkit, PICtail, REAL ICE, rLAB, Select Mode, SQI, Serial Quad I/O, Total Endurance, TSHARC, UniWinDriver, WiperLock, ZENA and Z-Scale are trademarks of Microchip Technology Incorporated in the U.S.A. and other countries.

SQTP is a service mark of Microchip Technology Incorporated in the U.S.A.

GestIC and ULPP are registered trademarks of Microchip Technology Germany II GmbH & Co. KG, a subsidiary of Microchip Technology Inc., in other countries.

All other trademarks mentioned herein are property of their respective companies.

© 2013, Microchip Technology Incorporated, Printed in the U.S.A., All Rights Reserved.

 Printed on recycled paper.

ISBN: 9781620774083

**QUALITY MANAGEMENT SYSTEM
CERTIFIED BY DNV
= ISO/TS 16949 =**

Microchip received ISO/TS-16949:2009 certification for its worldwide headquarters, design and wafer fabrication facilities in Chandler and Tempe, Arizona; Gresham, Oregon and design centers in California and India. The Company's quality system processes and procedures are for its PIC[®] MCUs and dsPIC[®] DSCs, KEELOQ[®] code hopping devices, Serial EEPROMs, microperipherals, nonvolatile memory and analog products. In addition, Microchip's quality system for the design and manufacture of development systems is ISO 9001:2000 certified.

Object of Declaration: EMC1182 Temperature Sensor Evaluation Board User's Guide

EU Declaration of Conformity

This declaration of conformity is issued by the manufacturer.

The development/evaluation tool is designed to be used for research and development in a laboratory environment. This development/evaluation tool is not a Finished Appliance, nor is it intended for incorporation into Finished Appliances that are made commercially available as single functional units to end users under EU EMC Directive 2004/108/EC and as supported by the European Commission's Guide for the EMC Directive 2004/108/EC (8th February 2010).

This development/evaluation tool complies with EU RoHS2 Directive 2011/65/EU.

For information regarding the exclusive, limited warranties applicable to Microchip products, please see Microchip's standard terms and conditions of sale, which are printed on our sales documentation and available at www.microchip.com.

Signed for and on behalf of Microchip Technology Inc. at Chandler, Arizona, USA

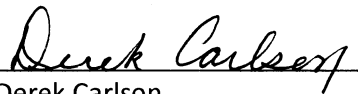

Derek Carlson

VP Development Tools

16-July-2013

Date

EMC1182 Temperature Sensor Evaluation Board User's Guide

NOTES:



EMC1182 TEMPERATURE SENSOR EVALUATION BOARD USER'S GUIDE

Table of Contents

Preface	7
Introduction.....	7
Document Layout	7
Conventions Used in this Guide	8
Recommended Reading.....	9
The Microchip Web Site	9
Customer Support	9
Document Revision History	9
Chapter 1. Product Overview	
1.1 Introduction	11
1.2 EMC1182 Device Features	11
1.3 What is the EMC1182 Temperature Sensor Evaluation Board?	11
1.4 What the EMC1182 Temperature Sensor Evaluation Board Kit Contains ...	12
Chapter 2. Installation and Operation	
2.1 Getting Started	13
2.1.1 System Requirements	13
2.1.2 Installing the Evaluation Board	13
Chapter 1. Hardware Description	
1.1 Introduction	19
1.1.1 Power Source	19
1.2 USB-to-SMBus Bridge	19
1.2.1 Direct SMBus Connect Option	19
1.2.2 Supplemental 1.8V SMBus Pull-up	19
1.3 Resistance Error Correction (REC)	20
1.4 Test Points	20
1.5 LED Indicators	20
1.6 Remote Diodes	21
1.7 Other Sensor Features	21
Chapter 2. Software Description	
2.1 Chip Manager Application Overview	23
2.1.1 Real-Time Register Graphs	23
2.1.2 Selecting Registers to Plot	24
2.1.3 Starting the Plots	25
2.1.4 Sampling a Plot	25
2.1.5 Exporting and Importing the Plot Data	26

EMC1182 Temperature Sensor Evaluation Board User's Guide

Appendix A. Schematic and Layouts

A.1 Introduction	27
A.2 Board – EMC1182 and Interface Schematic	28
A.3 Board – USB-to-SMBus Bridge Schematic	29
A.4 Board – Top Silk	30
A.5 Board – Top Pads	30
A.6 Board – Top Copper	30
A.7 Board – Bottom Copper	30
A.8 Board – Bottom Pads	30
A.9 Board – Bottom Silk	30

Appendix B. Bill of Materials (BOM)

Worldwide Sales and Service	34
-----------------------------------	----

Preface

NOTICE TO CUSTOMERS

All documentation becomes dated, and this manual is no exception. Microchip tools and documentation are constantly evolving to meet customer needs, so some actual dialogs and/or tool descriptions may differ from those in this document. Please refer to our web site (www.microchip.com) to obtain the latest documentation available.

Documents are identified with a “DS” number. This number is located on the bottom of each page, in front of the page number. The numbering convention for the DS number is “DSXXXXA”, where “XXXX” is the document number and “A” is the revision level of the document.

For the most up-to-date information on development tools, see the MPLAB® IDE online help. Select the Help menu, and then Topics to open a list of available online help files.

INTRODUCTION

This chapter contains general information that will be useful to know before using the EMC1182 Temperature Sensor Evaluation Board. Items discussed in this chapter include:

- Document Layout
- Conventions Used in this Guide
- Recommended Reading
- The Microchip Web Site
- Customer Support
- Document Revision History

DOCUMENT LAYOUT

This document describes how to use the EMC1182 Temperature Sensor Evaluation Board as a development tool to emulate and debug firmware on a target board. The manual layout is as follows:

- **Chapter 1. “Product Overview”** – Important information about the EMC1182 Temperature Sensor Evaluation Board.
- **Chapter 2. “Installation and Operation”** – Includes instructions on installing and starting the SMSC™ Chip Manager application.
- **Chapter 3. “Hardware Description”** – Shows hardware details of the EMC1182 Temperature Sensor Evaluation Board.
- **Chapter 4. “Software Description”** – Describes the main operations in the SMSC Chip Manager software.
- **Appendix A. “Schematic and Layouts”** – Shows the schematic and layout diagrams for the EMC1182 Temperature Sensor Evaluation Board.
- **Appendix B. “Bill of Materials (BOM)”** – Lists the parts used to build the EMC1182 Temperature Sensor Evaluation Board.

EMC1182 Temperature Sensor Evaluation Board User's Guide

CONVENTIONS USED IN THIS GUIDE

This manual uses the following documentation conventions:

DOCUMENTATION CONVENTIONS

Description	Represents	Examples
Arial font:		
Italic characters	Referenced books	<i>MPLAB[®] IDE User's Guide</i>
	Emphasized text	...is the <i>only</i> compiler...
Initial caps	A window	the Output window
	A dialog	the Settings dialog
	A menu selection	select Enable Programmer
Quotes	A field name in a window or dialog	"Save project before build"
Underlined, italic text with right angle bracket	A menu path	<u>File</u> > <i>Save</i>
Bold characters	A dialog button	Click OK
	A tab	Click the Power tab
N'Rnnnn	A number in verilog format, where N is the total number of digits, R is the radix and n is a digit.	4'b0010, 2'hF1
Text in angle brackets < >	A key on the keyboard	Press <Enter>, <F1>
Courier New font:		
Plain Courier New	Sample source code	#define START
	Filenames	autoexec.bat
	File paths	c:\mcc18\h
	Keywords	_asm, _endasm, static
	Command-line options	-Opa+, -Opa-
	Bit values	0, 1
	Constants	0xFF, 'A'
Italic Courier New	A variable argument	<i>file.o</i> , where <i>file</i> can be any valid filename
Square brackets []	Optional arguments	mcc18 [options] <i>file</i> [options]
Curly brackets and pipe character: { }	Choice of mutually exclusive arguments; an OR selection	errorlevel {0 1}
Ellipses...	Replaces repeated text	var_name [, var_name...]
	Represents code supplied by user	void main (void) { ... }

RECOMMENDED READING

This user's guide describes how to use the EMC1182 Temperature Sensor Evaluation Board. Another useful document is listed below. The following Microchip document is available and recommended as a supplemental reference resource.

- **EMC1182 Data Sheet – “Dual Channel 1.8V SMBus/I²C Temperature Sensor with Resistance Error Correction, Beta Compensation”**
(EMC1182 DS Rev. 1.0)

THE MICROCHIP WEB SITE

Microchip provides online support via our web site at www.microchip.com. This web site is used as a means to make files and information easily available to customers. Accessible by using your favorite Internet browser, the web site contains the following information:

- **Product Support** – Data sheets and errata, application notes and sample programs, design resources, user's guides and hardware support documents, latest software releases and archived software
- **General Technical Support** – Frequently Asked Questions (FAQs), technical support requests, online discussion groups, Microchip consultant program member listing
- **Business of Microchip** – Product selector and ordering guides, latest Microchip press releases, listing of seminars and events, listings of Microchip sales offices, distributors and factory representatives

CUSTOMER SUPPORT

Users of Microchip products can receive assistance through several channels:

- Distributor or Representative
- Local Sales Office
- Field Application Engineer (FAE)
- Technical Support

Customers should contact their distributor, representative or field application engineer (FAE) for support. Local sales offices are also available to help customers. A listing of sales offices and locations is included in the back of this document.

Technical support is available through the web site at:
<http://www.microchip.com/support>.

DOCUMENT REVISION HISTORY

Revision A (August 2013)

- Initial Release of this Document.

EMC1182 Temperature Sensor Evaluation Board User's Guide

NOTES:

Chapter 1. Product Overview

1.1 INTRODUCTION

The EMC1182 Temperature Sensor Evaluation Board provides an easily accessible platform to test the various features of the EMC1182. The System Management Bus (SMBus) communication is accomplished using an Universal Serial Bus (USB) bridge, providing a standard interface for the application code interface. The board is populated with a 3x3 DFN version of the EMC1182 device.

1.2 EMC1182 DEVICE FEATURES

The EMC1182 device is a two-channel SMBus temperature sensor featuring both pin-selectable and fixed SMBus address capability. The communications bus is also compatible with I²C communication protocol (see SMSC[®] application note AN 14.0 rev.1.1 - "SMSC Dedicated Slave Devices in I²C Systems" for details on the differences between the SMSC SMBus implementation and standard I²C/SMBus).

One externally connected temperature diode and one internal diode are available for temperature sensing. THERM and ALERT outputs have programmable temperature limits.

1.3 WHAT IS THE EMC1182 TEMPERATURE SENSOR EVALUATION BOARD?

All functions of the EMC1182 device can be tested and observed using the USB-based EMC1182 Temperature Sensor Evaluation Board. [Figure 1-1](#) shows the block diagram of this board.

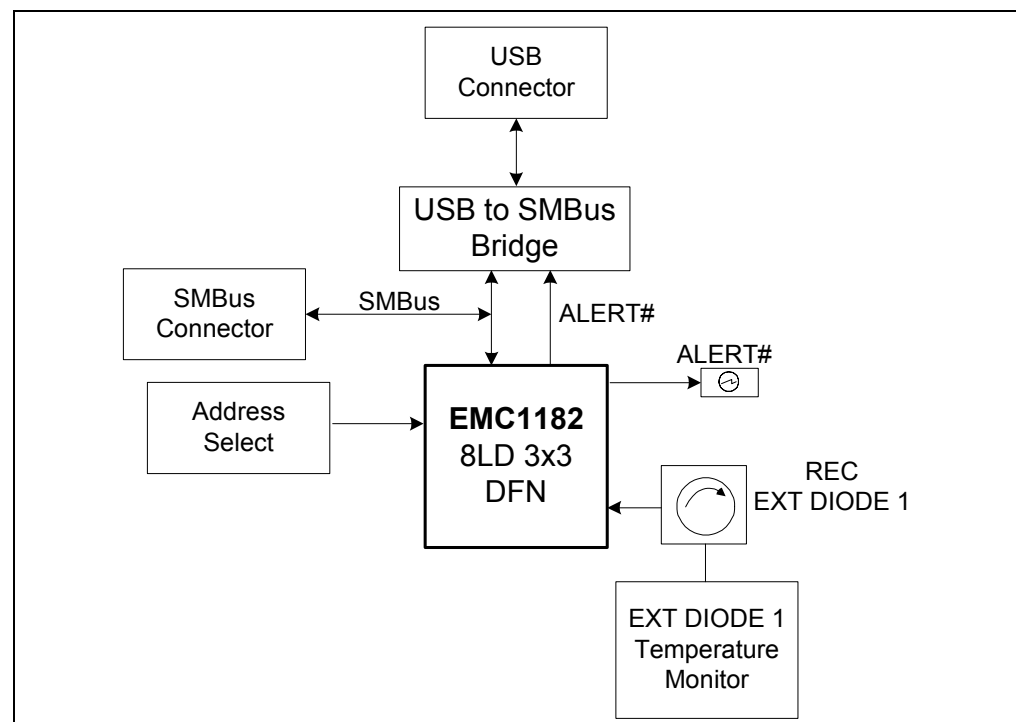

FIGURE 1-1: EMC1182 Temperature Sensor Evaluation Board Block Diagram.

EMC1182 Temperature Sensor Evaluation Board User's Guide

The evaluation system is comprised of the EMC1182 Temperature Sensor Evaluation Board and the SMSC Chip Manager application. The EMC1182 Temperature Sensor Evaluation Board has the following features:

- Headers for connecting an external diode or CPU/GPU
- Resistance Error Correction verification
- USB-to-SMBus bridge for power and communications
- Capability to connect directly to an external SMBus master

The user can perform the following operations using the Chip Manager:

- Viewing and changing register values
- Saving settings of all registers, allowing for quick configuration at a later time
- Graphing of any register

The evaluation board was designed for ease of use and experimentation purposes. [Figure 1-2](#) shows the top silk screen of the EMC1182 Temperature Sensor Evaluation Board.

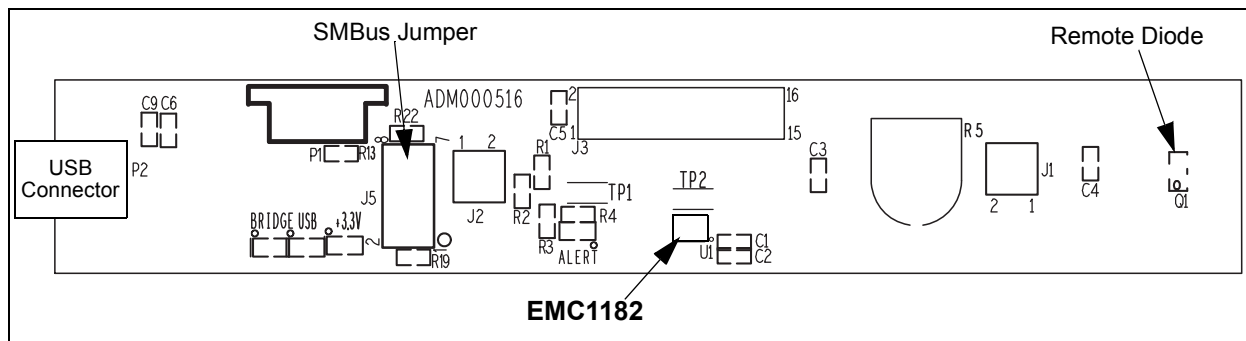

FIGURE 1-2: EMC1182 Temperature Sensor Evaluation Board Top Silk Screen.

1.4 WHAT THE EMC1182 TEMPERATURE SENSOR EVALUATION BOARD KIT CONTAINS

This EMC1182 Temperature Sensor Evaluation Board kit includes:

- EMC1182 Temperature Sensor Evaluation Board (ADM00516)
- Supplied USB cable
- Important Information Sheet

Chapter 2. Installation and Operation

2.1 GETTING STARTED

2.1.1 System Requirements

To use the EMC1182 Temperature Sensor Evaluation Board, the following are required:

- A PC running the Microsoft® Windows® operating system
- A display resolution of 800x600 or larger, for viewing several windows simultaneously
- An available USB port

2.1.2 Installing the Evaluation Board

Follow the next steps to install the SMC Chip Manager.

1. Download the `ChipMan.zip` file from the board web page. Unzip the archive. The application's revision history and install/uninstall notes may be found in the `readme.txt` file.
2. To install the Chip Manager application and the device driver on the PC, run the `Setup.exe`.
3. Connect the supplied USB cable to an available USB port on the PC. Plug the mini-B end of the USB cable into the board connector P3. The +3.3V and the Bridge ACT LEDs should illuminate.
4. If the USB Bridge driver has not previously been installed on the selected USB port, the Driver Software Installation window pops up, prompting for the driver install (see [Figure 2-1](#)).

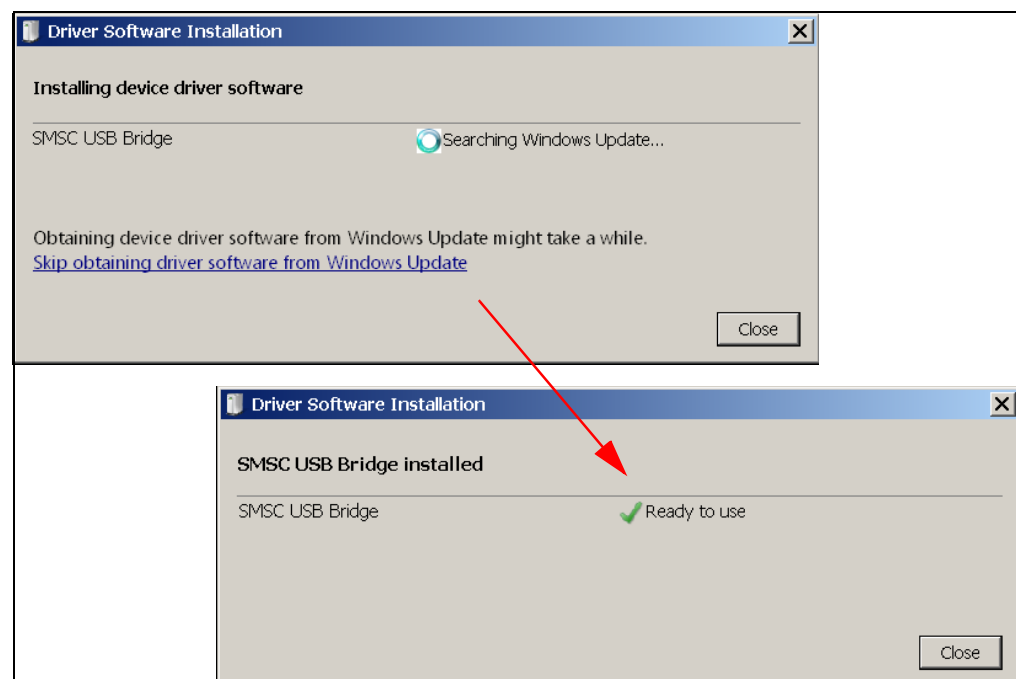

FIGURE 2-1: Device Driver Load and Complete.

EMC1182 Temperature Sensor Evaluation Board User's Guide

5. After the driver installation is complete, the initial setup screen for the Chip Manager application appears (see [Figure 2-2](#)). Click **Next** to start the installation.

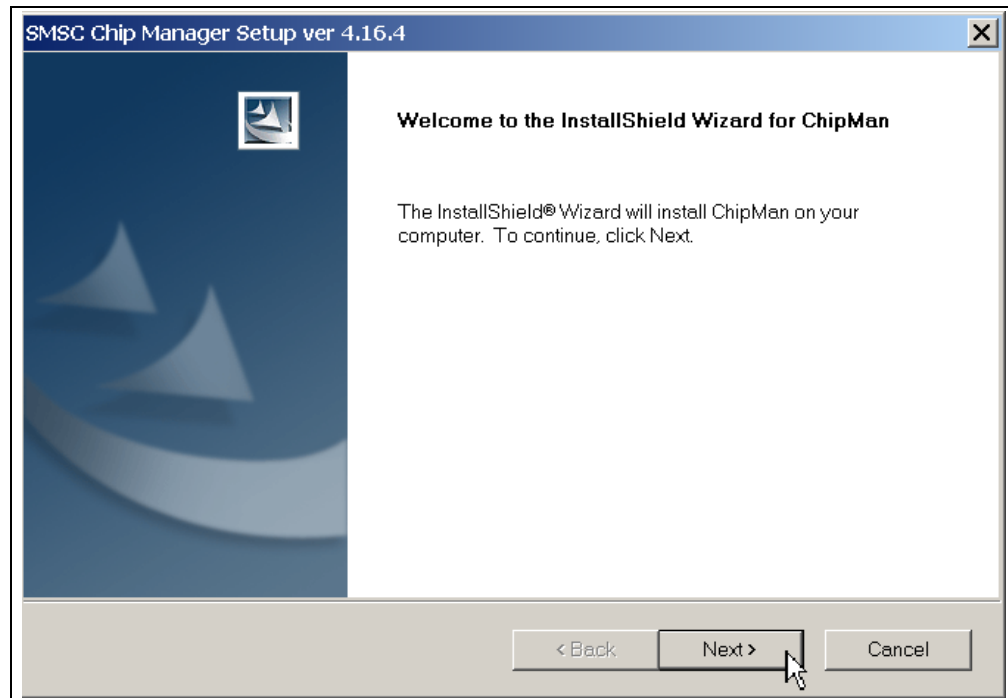

FIGURE 2-2: *InstallShield Wizard Startup Window.*

6. Read and accept the licensing agreement, in order to complete the installation. To continue, click **Yes**.

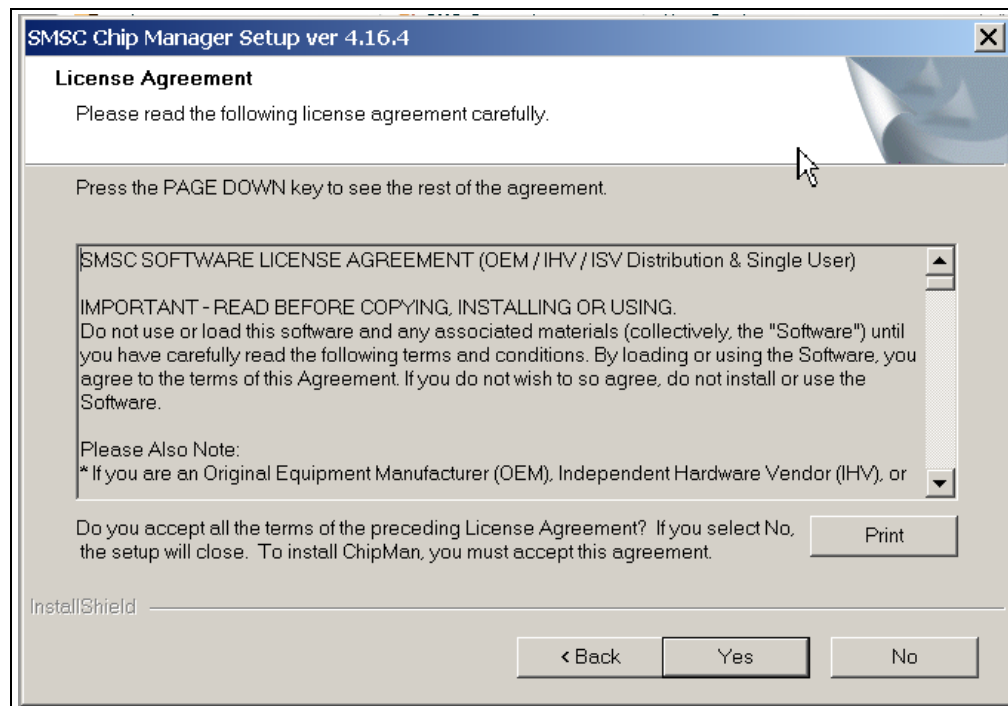

FIGURE 2-3: *License Agreement Dialog.*

Installation and Operation

7. On the Choose Destination Location dialog, browse for the desired location, or click **Next** to install in the default location (see [Figure 2-4](#)). The application setup window appears, showing the installation progress (see [Figure 2-5](#)).

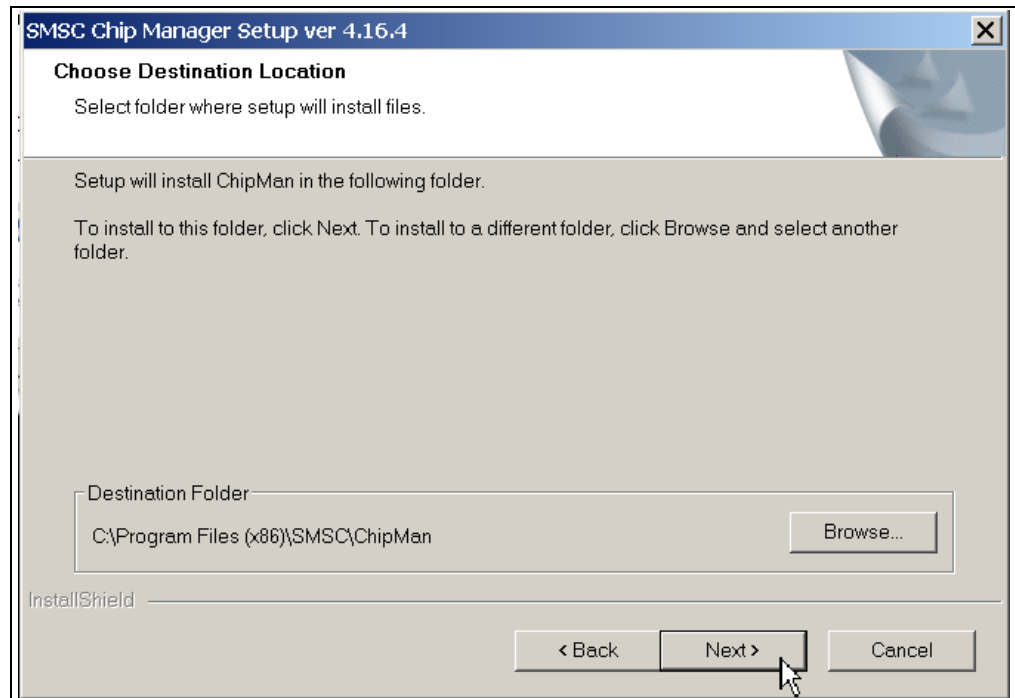

FIGURE 2-4: Destination Path Dialog.

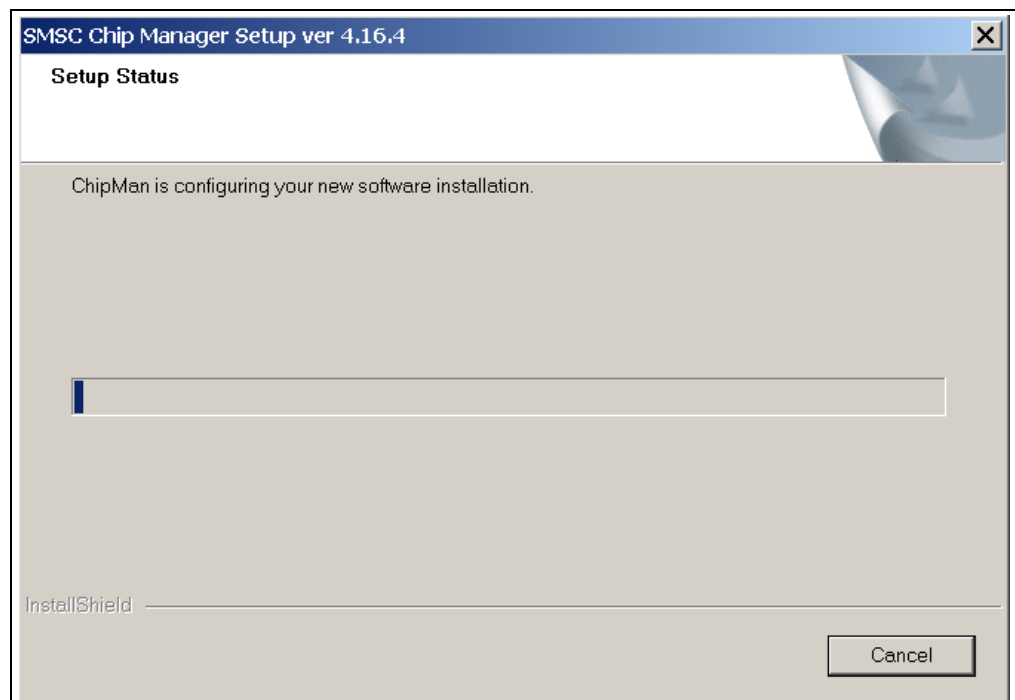

FIGURE 2-5: Setup Progress Window.

- After the setup is complete, the MSXML Parser used by the Chip Manager software is installed, as shown in [Figure 2-6](#). Once the setup completes successfully, press **Finish** to exit the install.

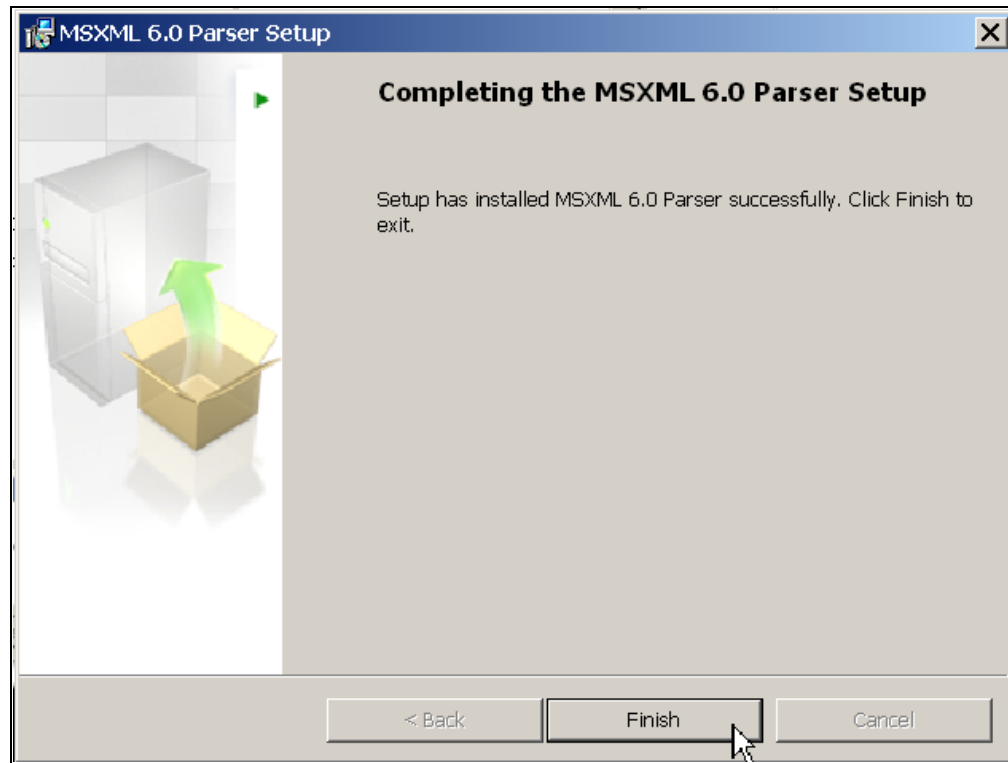

FIGURE 2-6: MSXML Parser Install Window.

- Start the software by either going to Windows *Start button* > *All Programs* > *SMSC* > *SMSC Chip Manager* or by double-clicking the software icon (📁) on the desktop. The evaluation board software will initialize and the SMSC Chip Manager with the Quick Help screen appears (see [Figure 2-7](#)).

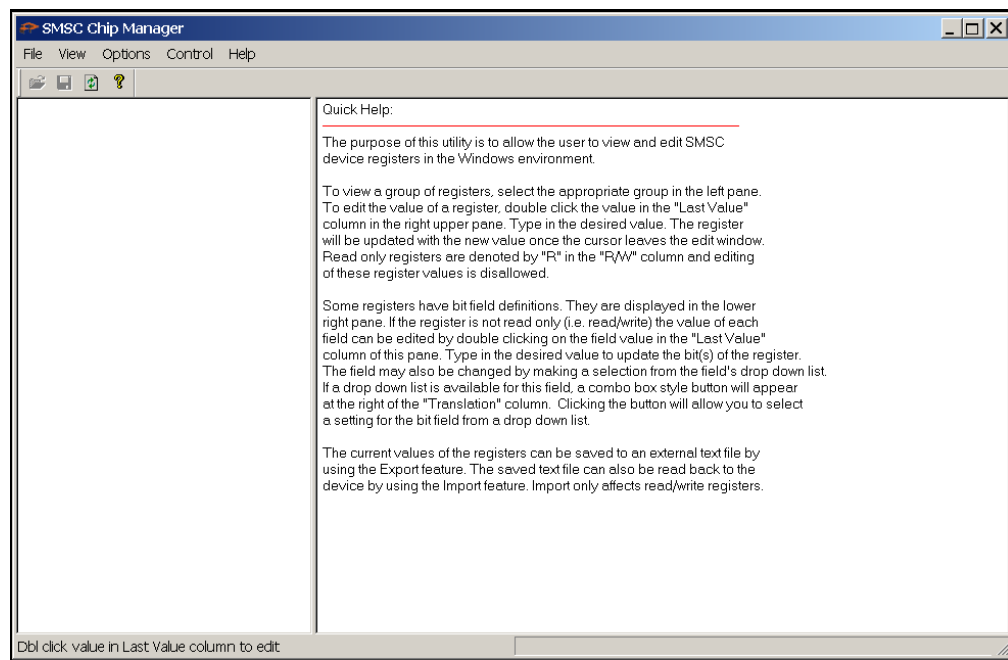

FIGURE 2-7: SMSC Chip Manager with Quick Help Window.

10. If a message stating that no device has been selected appears, click **Yes** to select a device. Alternatively, go to the Chip Manager's main menu, select **Options > Select Device**. In either case, the Select SMSC Device window displays, as shown in [Figure 2-8](#).

In the "SMSC Device" list, choose EMC1182. From the "Master Controller" drop-down list choose "SMBus USB-SMB-SPI Bridge". Click **OK** to complete the device selection.

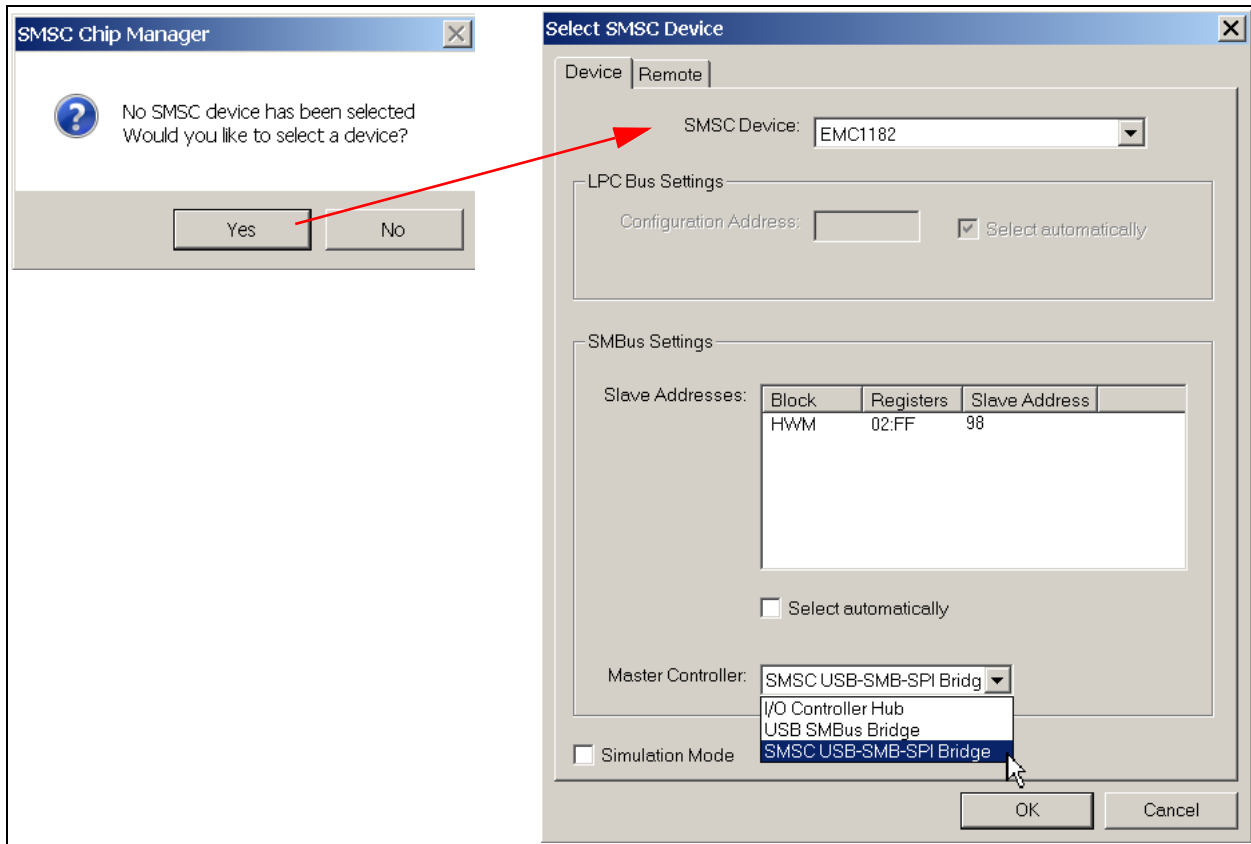

FIGURE 2-8: Select SMSC Device Window.

EMC1182 Temperature Sensor Evaluation Board User's Guide

- From the Chip Manager main menu, ensure that *Options > Auto refresh Registers* is checked. In the left panel, click the hardware monitor (HWM) to expand the content, then select any of the register groups, as shown in [Figure 2-9](#). The USB Activity LED on the board starts blinking when any of the register groups are selected. The register values are automatically updated every second when the Auto Refresh option is on.

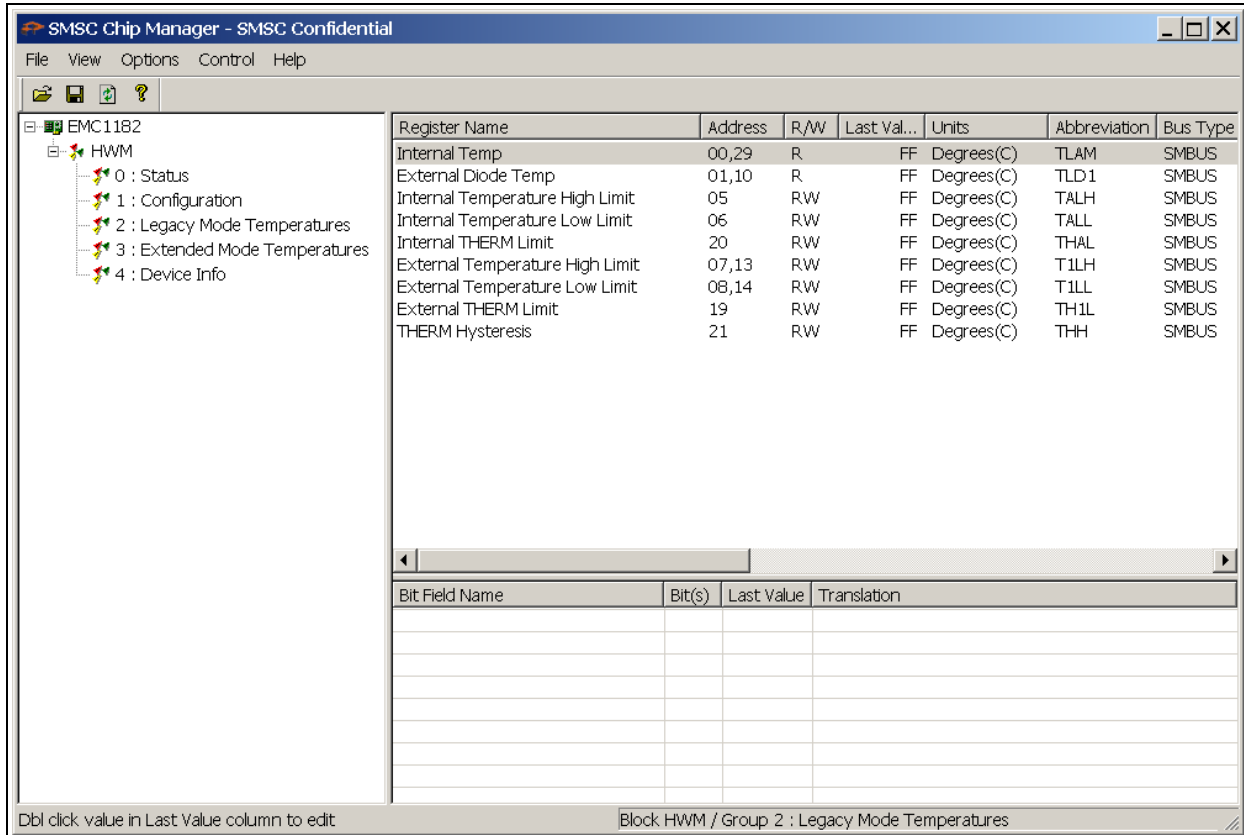

FIGURE 2-9: Chip Manager Register Groups.

Chapter 3. Hardware Description

3.1 INTRODUCTION

The EMC1182 Temperature Sensor Evaluation Board provides the means to demonstrate all of the EMC1182 features, and allows the registers to be viewed and modified. LEDs indicating status information and test points are included to enable system voltage monitoring, using a voltmeter or an oscilloscope.

3.1.1 Power Source

The board requires only one universal serial bus (USB) connection to power the board. The USB-to-SMBus bridge regulates the +5V USB power to +3.3V used by the EMC1182 and other evaluation board circuitry.

3.2 USB-TO-SMBUS BRIDGE

The USB-to-SMBus bridge is based on an 8-bit microcontroller with integrated USB and SMBus interfaces, as well as internal flash and RAM. During the evaluation board manufacturing process, the firmware is loaded into the bridge that provides the interface between the USB and the SMBus. Power is sourced to the microcontroller from the USB interface for device power and communication.

3.2.1 Direct SMBus Connect Option

It is also possible to connect an external SMBus master to the EMC1182 Temperature Sensor Evaluation Board. A few jumper settings are required to drive the EMC1182 on the evaluation board, as explained in the following steps:

- Remove the jumpers on header JP10 and connect the SMBus master to the SDA, SCL and ALERT pins (3, 5 and 7, respectively), as well as an external supply for +3.3V (pin 1).
- Remove resistors R19, R20, R22 and R25, shown in [Figure 3-1](#).
- The +3.3V can be supplied by the SMBus bridge by leaving the +3.3V jumper in place and retaining the USB connection.

3.2.2 Supplemental 1.8V SMBus Pull-up

A 1.8V (nominal) linear regulator is placed on the board along with the jumpers to connect SDA and SCL to a 1.8V pull-up supply. Once the jumper resistors are disconnected, jumpers connecting J2-1 to J2-2 and J2-3 to J2-4 may be installed to activate the 1.8V pull-ups. This jumper is identified in [Figure 3-1](#) by the blue circle.

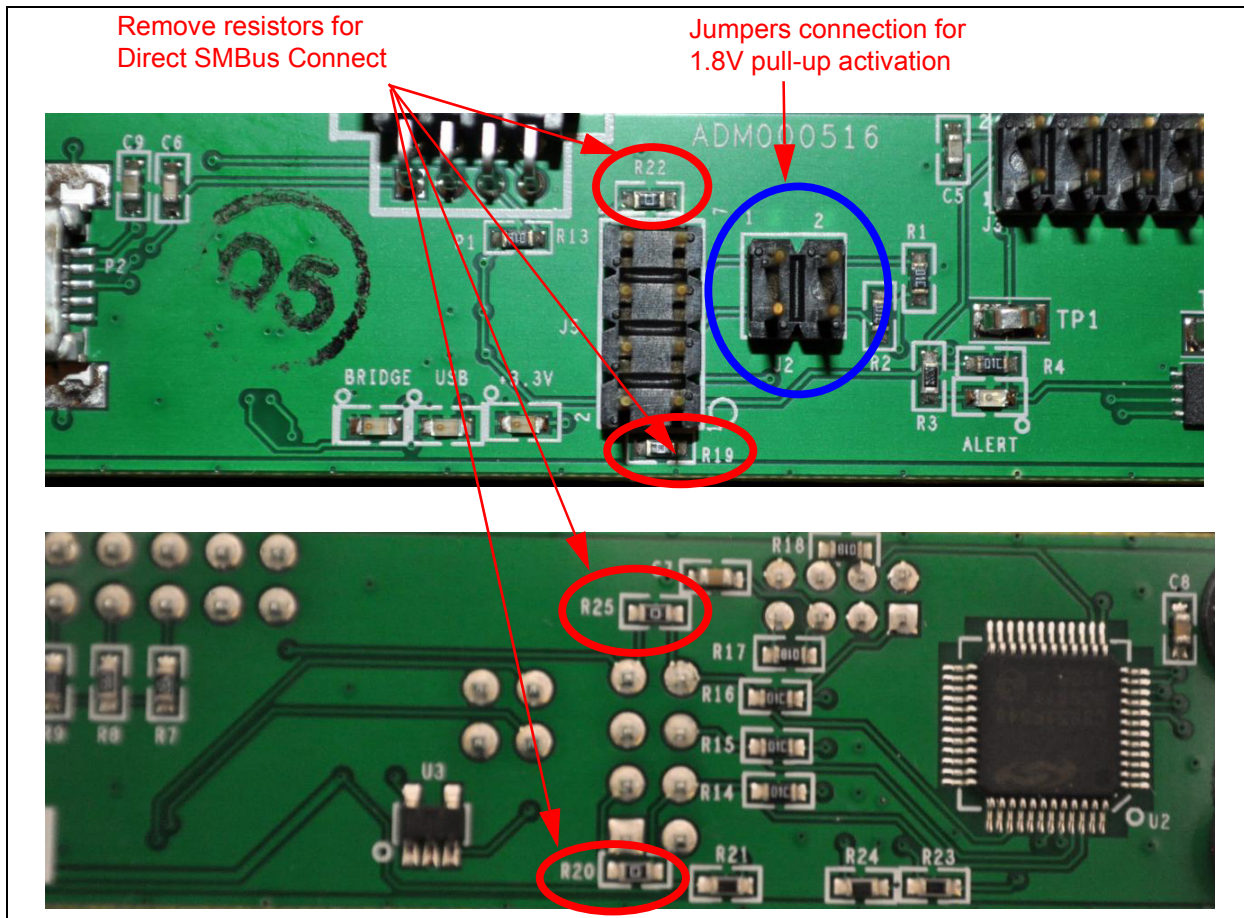

FIGURE 3-1: SMBus Jumper Resistors.

3.3 RESISTANCE ERROR CORRECTION (REC)

The external diode 1 (Q1) on the board has a series resistance adjustment on the DN line. Checking the Resistance Error Correction (REC) feature is accomplished by turning the resistor wheel R5. With the REC on, the temperature will not change as the wheel is turned. With REC off, a significant temperature error will occur.

3.4 TEST POINTS

The EMC1182 Temperature Sensor Evaluation Board includes test points for the following:

- $\overline{\text{ALERT}}$ output (TP1)
- THERM output (TP2)

3.5 LED INDICATORS

Table 3-1 details the LEDs status of the following signals:

TABLE 3-1: LED STATUS INDICATORS

LED No.	Signal	When LED is OFF	When LED is ON	Color
LED1	$\overline{\text{ALERT}}$	+3.3V power OFF	$\overline{\text{ALERT}}$	red
LED3	+3.3V	+3.3V power OFF	+3.3V power ON	green
LED4	Bridge Activity	NO Activity on USB/SMBus Bridge	Activity on USB/SMBus Bridge	green
LED5	USB Activity	NO Activity on USB port	Activity on USB port	green

3.6 REMOTE DIODES

The evaluation board is populated with jumpers to connect to the on-board diode or an off-board diode (see [Table 3-2](#)).

To connect to an off-board CPU or GPU, remove both jumpers from header J1. Then connect Pin 1 to the 'remote+' terminal of the off-board diode and Pin 2 to the 'remote-' terminal of the off-board diode. Make sure a common ground exists between the off-board diode (GPU, etc.) and the evaluation board. Ensure that the off-board diode is properly biased. Consult the CPU manufacturer's data sheet for guidance on interfacing to the thermal diode. Refer to the EMC1182 Temperature Sensor Evaluation Board schematic in [Appendix A. "Schematic and Layouts"](#) for details on the evaluation board header connections.

TABLE 3-2: REMOTE DIODE CONFIGURATIONS

Jumper	Configuration	Pin 1	Pin 2	Pin 3	Pin 4
J1	On-board diode (Q1)	short/DP		short/DN	
	General purpose remote diode	open	remote+/DP	open	remote-/DN
	CPU/GPU diode	good common ground			

3.7 OTHER SENSOR FEATURES

Other features, such as Conversion Rate, Dynamic Averaging and Digital Filtering, can be controlled with the EMC1182 registers. Refer to the device data sheet for details on the register description.

EMC1182 Temperature Sensor Evaluation Board User's Guide

NOTES:

Chapter 4. Software Description

4.1 CHIP MANAGER APPLICATION OVERVIEW

The Chip Manager application enables the user to display temperature readings, set temperature limits and read/write configuration register values. The Chip Manager initially displays a Quick Help screen (see [Figure 2-7](#)). For detailed information on application features and usage, select *Help > Contents* to display the HTML-based Help document, as shown in [Figure 4-1](#).

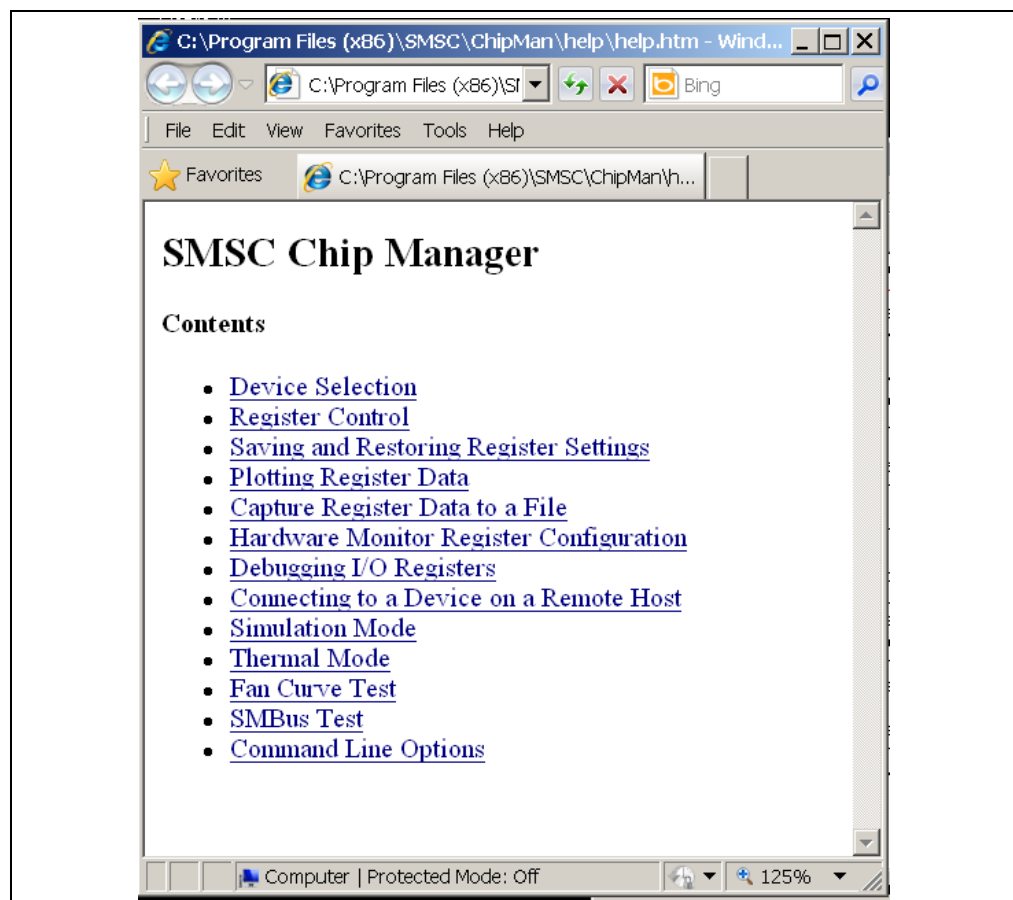

FIGURE 4-1: *Chip Manager Help Screen.*

4.1.1 Real-Time Register Graphs

The Chip Manager software has the ability to plot register values in real-time, up to a 10 Hz continuous rate.

4.1.2 Selecting Registers to Plot

- To plot a register, right-click the desired register name or value. Select the “Add Register(s) to Plot” from the context menu (see Figure 4-2), to add the register or value to the plot list.

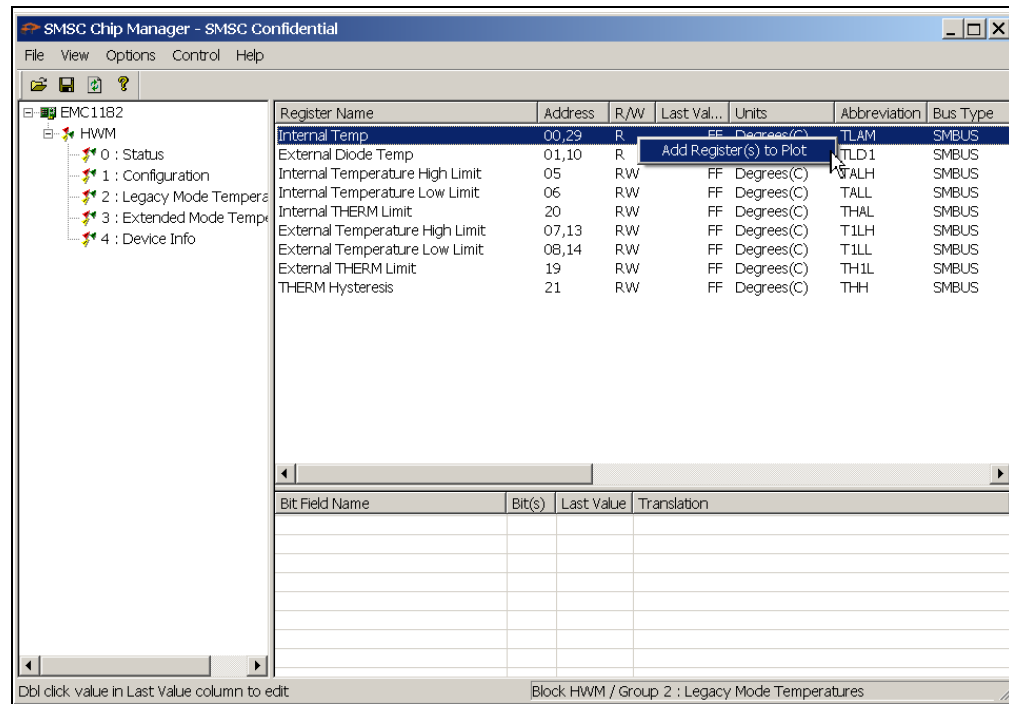

FIGURE 4-2: Adding Registers to Plot.

- Once the desired register is added to be plotted, a graphic plot window will appear with a legend on top, as shown in Figure 4-3. The two windows can be rearranged independently.

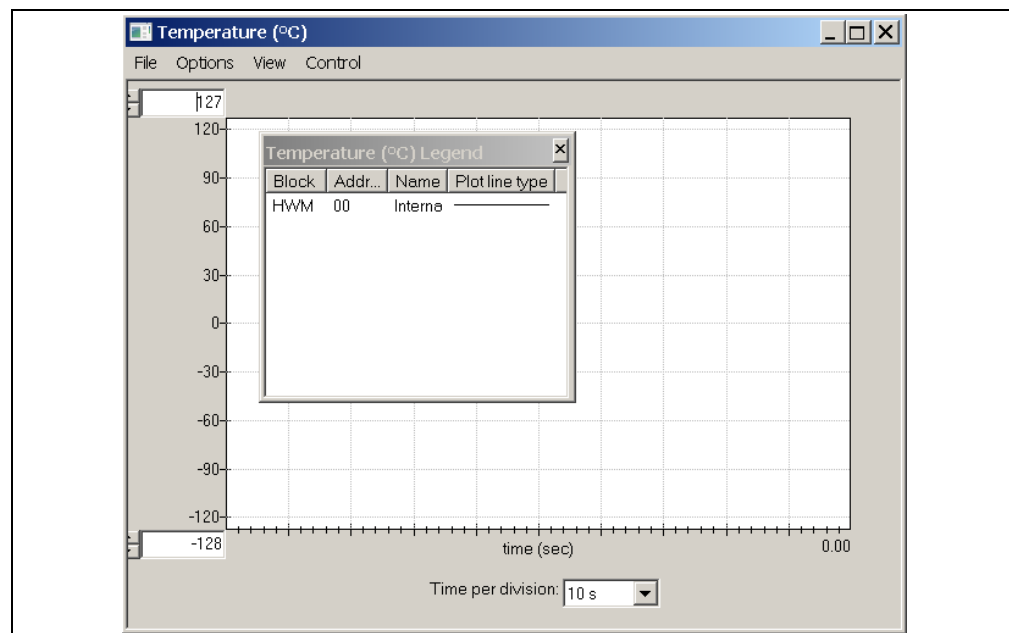

FIGURE 4-3: Register Plot Window.

- To plot additional registers, go back to the Chip Manager main window and repeat Step 1.

4.1.3 Starting the Plots

All plots can be started simultaneously by selecting *Control > Plots > Start All Plots* from the menu, in the main application window. Multiple plots will be in sync if they are started simultaneously.

Individual plots may be paused at any time by clicking *Control > Pause* in the plot window. This will not cause loss of captured data on the other plot windows.

For a better view on the plot, select a different “Time per division” value in the drop-down menu at the bottom of the plotting window. This scale change affects both the real-time mode and the playback mode, while the rate at which data is recorded is unaffected.

4.1.4 Sampling a Plot

Figure 4-4 is an example of temperature history. Internal Temperature, External Diode 1 Temperature and External Diode 1 High Limit are selected for plotting. The results after the plot starting are that the External Diode Temperature High Limit is reduced, the External diode 1 starts at room temperature and is then heated by simply placing a finger on the external diode Q1.

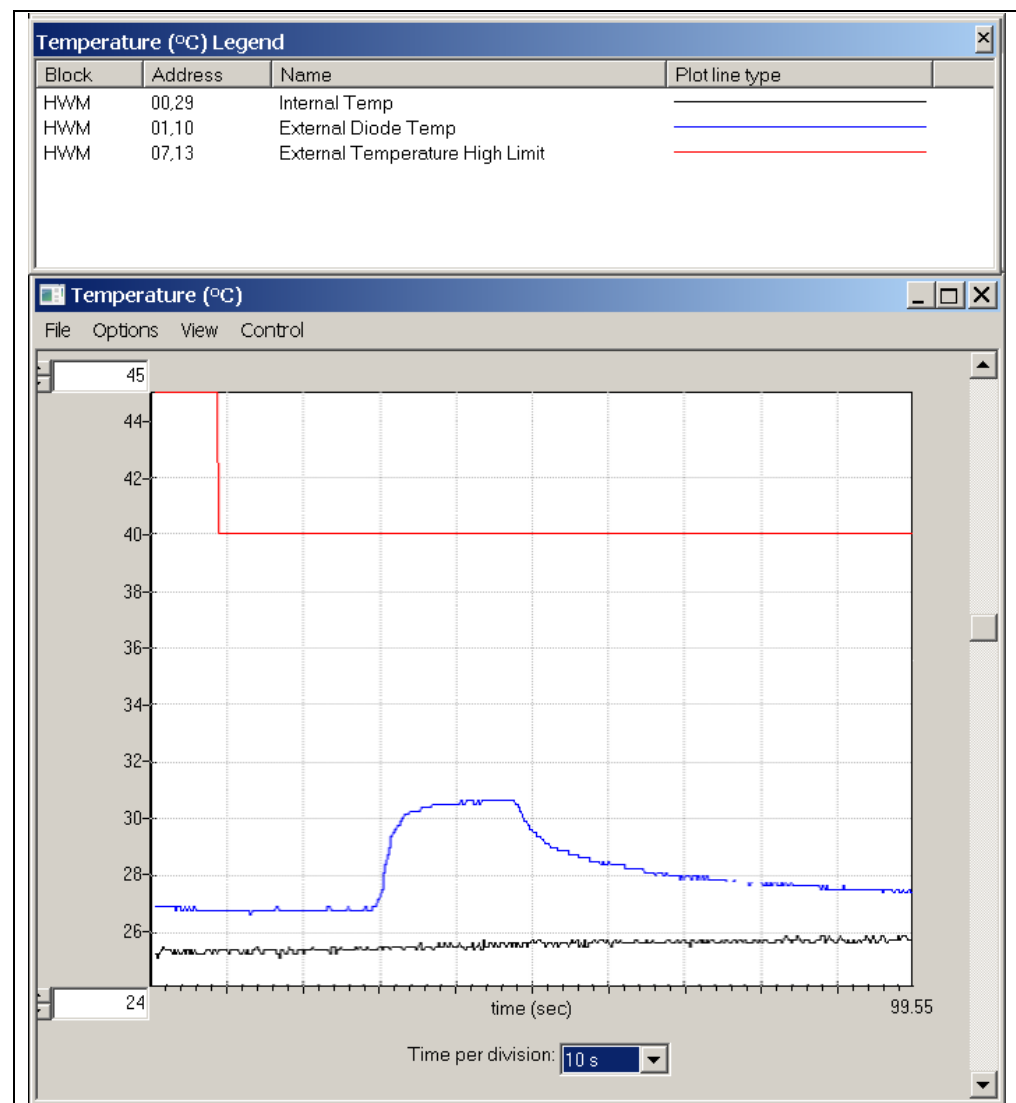

FIGURE 4-4: EMC1182 Temperature History Graph.

4.1.5 Exporting and Importing the Plot Data

The data on each plot window may be stored in a semicolon-separated text file. To save the data, follow the steps:

1. Stop the plotting by selecting Control > Stop from the plot window, or Control > Plots > Stop All Plots from the Chip Manager main window.
2. Select File > Export from the plot window to save the data.

To review saved data:

1. Select File > Import from an open plot window and then select the file name to open.

Note: Importing a saved data file into a plot window with a different data type is not allowed by the Chip Manager application. In this case, a warning message will display. It is recommended to choose a file name that reflects the data type when exporting the plot data.



EMC1182 TEMPERATURE SENSOR EVALUATION BOARD USER'S GUIDE

Appendix A. Schematic and Layouts

A.1 INTRODUCTION

This appendix contains the following schematics and layouts for the EMC1182 Temperature Sensor Evaluation Board:

- Board – EMC1182 and Interface Schematic
- Board – USB-to-SMBus Bridge Schematic
- Board – Top Silk
- Board – Top Pads
- Board – Top Copper
- Board – Bottom Copper
- Board – Bottom Pads
- Board – Bottom Silk

A.2 BOARD – EMC1182 AND INTERFACE SCHEMATIC

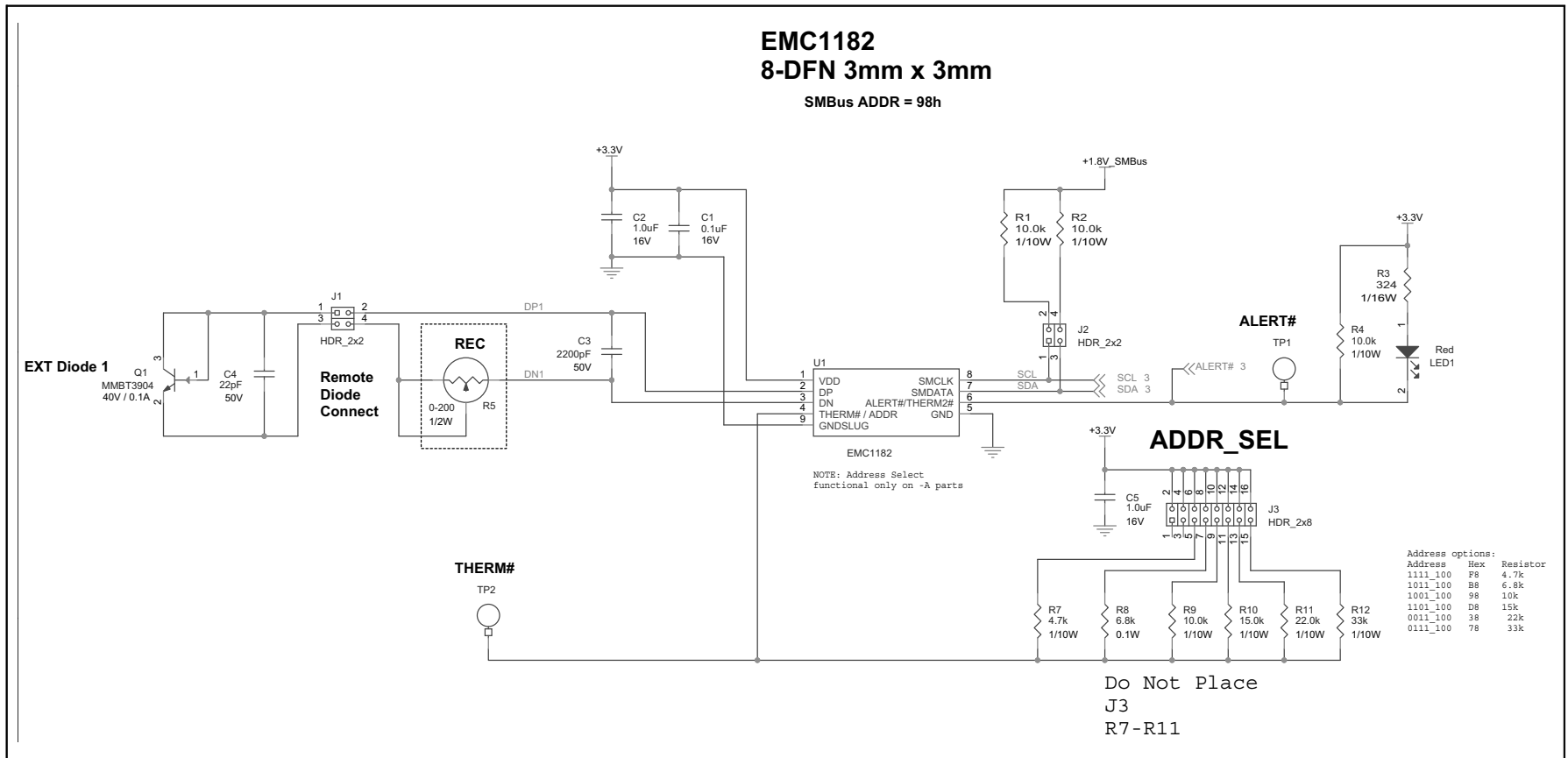

A.3 BOARD – USB-TO-SMBUS BRIDGE SCHEMATIC

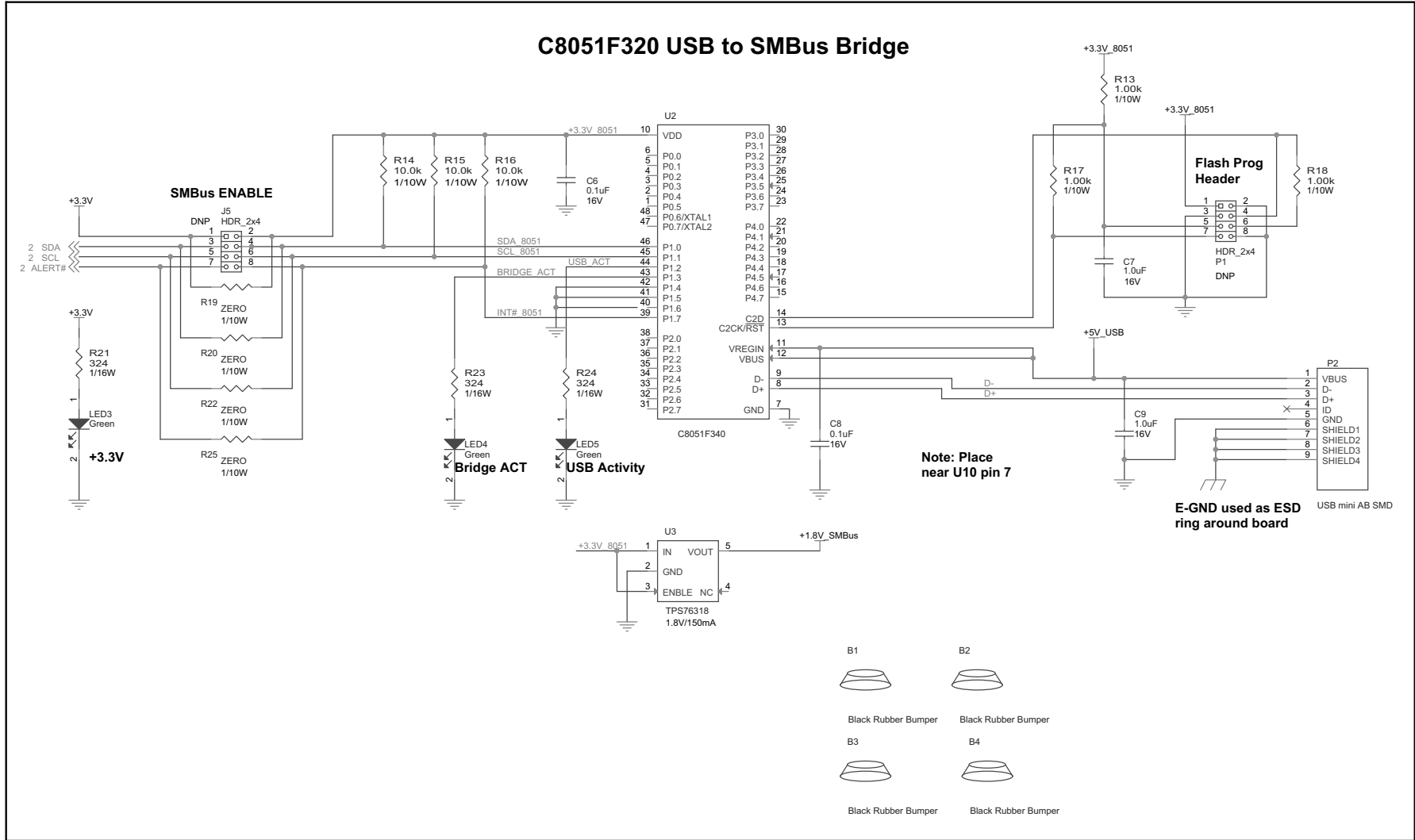

EMC1182 Temperature Sensor Evaluation Board User's Guide

A.4 BOARD – TOP SILK

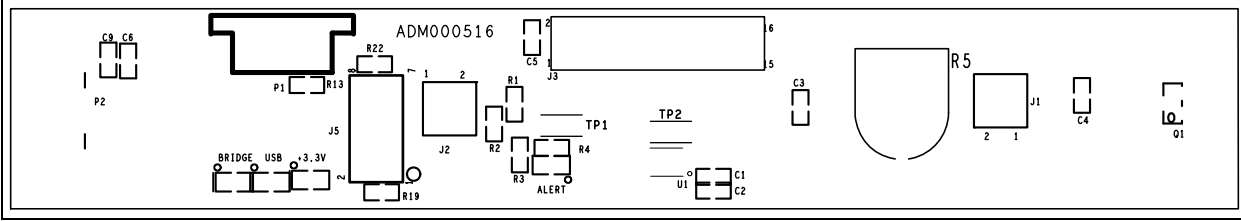

A.5 BOARD – TOP PADS

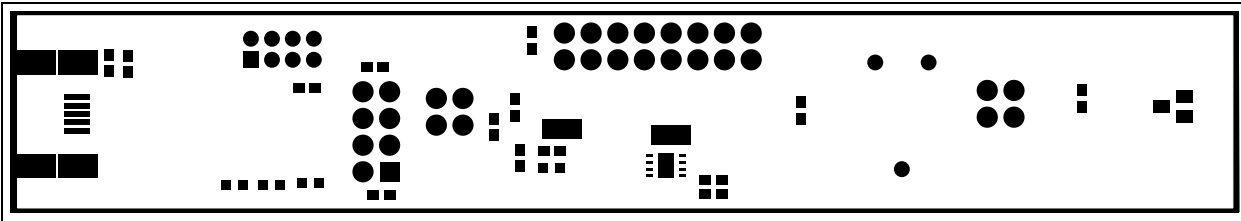

A.6 BOARD – TOP COPPER

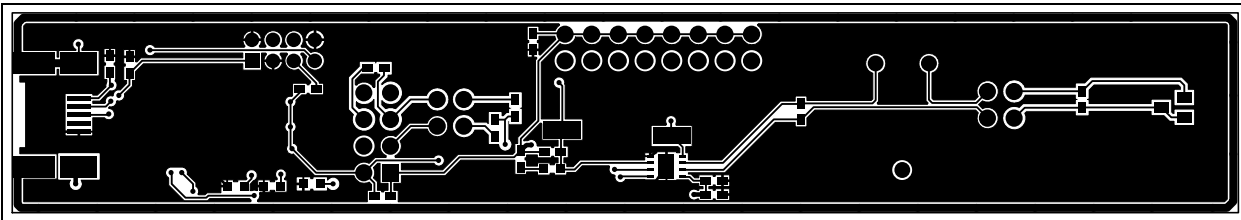

A.7 BOARD – BOTTOM COPPER

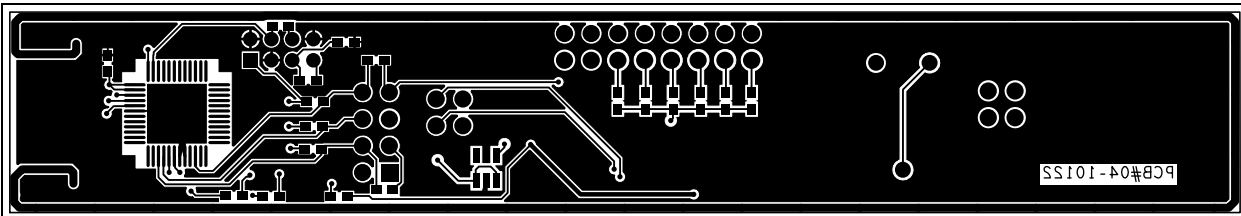

A.8 BOARD – BOTTOM PADS

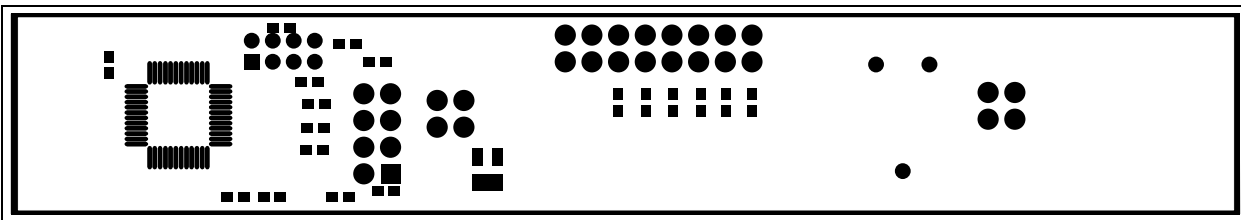

A.9 BOARD – BOTTOM SILK

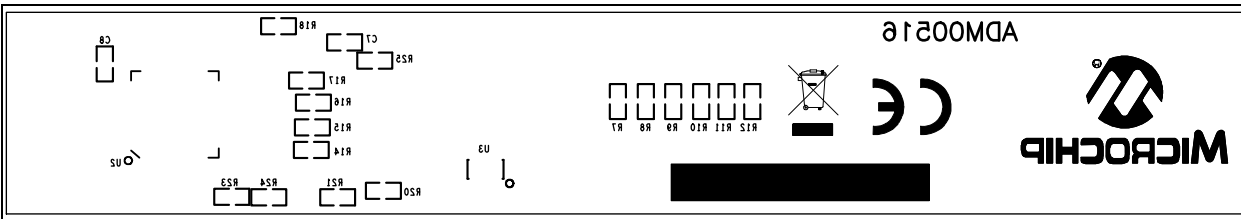

Appendix B. Bill of Materials (BOM)

TABLE B-1: BILL OF MATERIAL (BOM)

Qty.	Reference	Description	Manufacturer	Part Number
4	B1, B2, B3, B4	Bumper blk .3705.19" cylinder	Richco [®] , Inc.	RBS-35BK
3	C1, C6, C8	Capacitor ceramic 0.1 µF 16V 10% X7R 0603	Panasonic [®] - ECG	ECJ-1VB1C104K
4	C2, C5, C7, C9	Capacitor ceramic 1.0 µF 16 VDC 10% X5R 06	Panasonic - ECG	ECJ-1VB1C105K
1	C3	Capacitor ceramic 2200 pF 50V 20% X7R 060	Murata Electronics [®]	GRM188R71H222MA01D
1	C4	Capacitor ceramic 22 pF 50V NP0 0603	KEMET [®]	C0603C220J5GACTU
2	J1, J2	Header, 2 X 2, 0.1 inch, vertical	Samtec, Inc.	TSW-102-07-L-D
0	J3	Header, 2 X 8, 0.1 inch, vertical	Samtec, Inc.	TSW-108-07-L-D
1	J3	Header, 1 X 2, 0.1 Inch, vertical, DO NOT POPULATE	Molex [®] Connector Corporation	22-28-4020
1	J5	Header, 2 X 4, 0.1 INCH, vertical	Samtec, Inc.	TSW-104-07-L-D
1	LED1	LED red clear 0603 SMT	Lite-On [®] Technology Corporation	LTST-C190CKT
3	LED3, LED4, LED5	LED green SMT	Stanley Electric Co., Ltd.	BG1111C-TR
1	P1	Connector Header 8 POS 2MM right angle gold	Molex Connector Corporation	87833-0820
1	P2	Connector recept. USB mini AB 5 POS right angle	Molex Connector Corporation	56579-0576
1	PCB	EMC1182 Temperature Sensor Evaluation Board – Printed Circuit Board	—	104-00516
1	Q1	Transistor NPN SOT-23 MMBT3904	Fairchild Semiconductor [®]	MMBT3904
6	R1, R2, R4, R14, R15, R16	Resistor 10.0K Ohm 1/10W 1% 0603	Yageo Corporation	RC0603FR-0710KL
0	R10	Resistor 15.0K Ohm 1/10W 1% 0603 SMD, DO NOT POPULATE	Yageo Corporation	RC0603FR-0715KL
0	R11	Resistor 22.0K Ohm 1/16W 1% 0603 SMD, DO NOT POPULATE	Yageo Corporation	RC0603FR-0722KL
1	R12	Resistor 33K Ohm 1/10W 1% 0603	Yageo Corporation	RC0603FR-0733KL
3	R13, R17, R18	Resistor 1.00K Ohm 1/10W 1% 0603 SMD	Yageo Corporation	RC0603FR-071KL
4	R19, R20, R22, R25	Resistor zero Ohm 1/10W 5% 0603	Yageo Corporation	RC0603JR-070RL
4	R3, R21, R23, R24	Resistor 324 Ohm 1/16W 1% 0603	Panasonic - ECG	ERJ-3EKF3240V
1	R5	Trimpot 200 Ohm thumb wheel	Bourns [®] , Inc.	3352E-1-201LF

Note 1: The components listed in this Bill of Materials are representative of the PCB assembly. The released BOM used in manufacturing uses all RoHS-compliant components.

EMC1182 Temperature Sensor Evaluation Board User's Guide

TABLE B-1: BILL OF MATERIAL (BOM) (CONTINUED)

Qty.	Reference	Description	Manufacturer	Part Number
0	R7	Resistor 4.7K Ohm 1/10W 1% 0603 SMD, DO NOT POPULATE	Yageo Corporation	9C06031A4701FKHFT
0	R8	Resistor 6.8K OHM 0.1W 5% 0603, DO NOT POPULATE	Yageo Corporation	RC0603JR-076K8L
0	R9	Resistor 10.0K OHM 1/10W 1% 0603, DO NOT POPULATE	Yageo Corporation	RC0603FR-0710KL
2	TP1, TP2	TEST POINT	Keystone Electronics Corp.	5015
1	U1	Dual Channel 1.8V SMBus/I ² C Temperature Sensor with Resistance Error Correction, Beta Compensation	Microchip Technology Inc.	EMC1182-1-AIA-TR
1	U2	IC 8051 MCU Flash 64K 48 TQFP	Silicon Laboratories® Inc.	C8051F340-GQ
1	U3	IC LDO Reg. 150 MA 1.8V SOT23-5	Texas Instruments	TPS76318QDBVRQ1

Note 1: The components listed in this Bill of Materials are representative of the PCB assembly. The released BOM used in manufacturing uses all RoHS-compliant components.

Bill of Materials (BOM)

NOTES:



MICROCHIP

Worldwide Sales and Service

AMERICAS

Corporate Office
2355 West Chandler Blvd.
Chandler, AZ 85224-6199
Tel: 480-792-7200
Fax: 480-792-7277
Technical Support:
<http://www.microchip.com/support>
Web Address:
www.microchip.com

Atlanta
Duluth, GA
Tel: 678-957-9614
Fax: 678-957-1455

Boston
Westborough, MA
Tel: 774-760-0087
Fax: 774-760-0088

Chicago
Itasca, IL
Tel: 630-285-0071
Fax: 630-285-0075

Cleveland
Independence, OH
Tel: 216-447-0464
Fax: 216-447-0643

Dallas
Addison, TX
Tel: 972-818-7423
Fax: 972-818-2924

Detroit
Farmington Hills, MI
Tel: 248-538-2250
Fax: 248-538-2260

Indianapolis
Noblesville, IN
Tel: 317-773-8323
Fax: 317-773-5453

Los Angeles
Mission Viejo, CA
Tel: 949-462-9523
Fax: 949-462-9608

Santa Clara
Santa Clara, CA
Tel: 408-961-6444
Fax: 408-961-6445

Toronto
Mississauga, Ontario,
Canada
Tel: 905-673-0699
Fax: 905-673-6509

ASIA/PACIFIC

Asia Pacific Office
Suites 3707-14, 37th Floor
Tower 6, The Gateway
Harbour City, Kowloon
Hong Kong
Tel: 852-2401-1200
Fax: 852-2401-3431

Australia - Sydney
Tel: 61-2-9868-6733
Fax: 61-2-9868-6755

China - Beijing
Tel: 86-10-8569-7000
Fax: 86-10-8528-2104

China - Chengdu
Tel: 86-28-8665-5511
Fax: 86-28-8665-7889

China - Chongqing
Tel: 86-23-8980-9588
Fax: 86-23-8980-9500

China - Hangzhou
Tel: 86-571-2819-3187
Fax: 86-571-2819-3189

China - Hong Kong SAR
Tel: 852-2943-5100
Fax: 852-2401-3431

China - Nanjing
Tel: 86-25-8473-2460
Fax: 86-25-8473-2470

China - Qingdao
Tel: 86-532-8502-7355
Fax: 86-532-8502-7205

China - Shanghai
Tel: 86-21-5407-5533
Fax: 86-21-5407-5066

China - Shenyang
Tel: 86-24-2334-2829
Fax: 86-24-2334-2393

China - Shenzhen
Tel: 86-755-8864-2200
Fax: 86-755-8203-1760

China - Wuhan
Tel: 86-27-5980-5300
Fax: 86-27-5980-5118

China - Xian
Tel: 86-29-8833-7252
Fax: 86-29-8833-7256

China - Xiamen
Tel: 86-592-2388138
Fax: 86-592-2388130

China - Zhuhai
Tel: 86-756-3210040
Fax: 86-756-3210049

ASIA/PACIFIC

India - Bangalore
Tel: 91-80-3090-4444
Fax: 91-80-3090-4123

India - New Delhi
Tel: 91-11-4160-8631
Fax: 91-11-4160-8632

India - Pune
Tel: 91-20-2566-1512
Fax: 91-20-2566-1513

Japan - Osaka
Tel: 81-6-6152-7160
Fax: 81-6-6152-9310

Japan - Tokyo
Tel: 81-3-6880-3770
Fax: 81-3-6880-3771

Korea - Daegu
Tel: 82-53-744-4301
Fax: 82-53-744-4302

Korea - Seoul
Tel: 82-2-554-7200
Fax: 82-2-558-5932 or
82-2-558-5934

Malaysia - Kuala Lumpur
Tel: 60-3-6201-9857
Fax: 60-3-6201-9859

Malaysia - Penang
Tel: 60-4-227-8870
Fax: 60-4-227-4068

Philippines - Manila
Tel: 63-2-634-9065
Fax: 63-2-634-9069

Singapore
Tel: 65-6334-8870
Fax: 65-6334-8850

Taiwan - Hsin Chu
Tel: 886-3-5778-366
Fax: 886-3-5770-955

Taiwan - Kaohsiung
Tel: 886-7-213-7828
Fax: 886-7-330-9305

Taiwan - Taipei
Tel: 886-2-2508-8600
Fax: 886-2-2508-0102

Thailand - Bangkok
Tel: 66-2-694-1351
Fax: 66-2-694-1350

EUROPE

Austria - Wels
Tel: 43-7242-2244-39
Fax: 43-7242-2244-393

Denmark - Copenhagen
Tel: 45-4450-2828
Fax: 45-4485-2829

France - Paris
Tel: 33-1-69-53-63-20
Fax: 33-1-69-30-90-79

Germany - Munich
Tel: 49-89-627-144-0
Fax: 49-89-627-144-44

Italy - Milan
Tel: 39-0331-742611
Fax: 39-0331-466781

Netherlands - Drunen
Tel: 31-416-690399
Fax: 31-416-690340

Spain - Madrid
Tel: 34-91-708-08-90
Fax: 34-91-708-08-91

UK - Wokingham
Tel: 44-118-921-5869
Fax: 44-118-921-5820

11/29/12