

THIS DRAWING IS UNPUBLISHED. RELEASED FOR PUBLICATION, 19 .
 © COPYRIGHT 19 BY AMP INCORPORATED. ALL INTERNATIONAL RIGHTS RESERVED.

LOC	DIST	P	F	REVISIONS				
				ZONE	LTR	DESCRIPTION	DATE	APPD
AR	39				0	RELEASED TO CUST AR2289	1-89	-
					A	SUPSD -2 PER EC 0020-542-94	12/21/94	GM

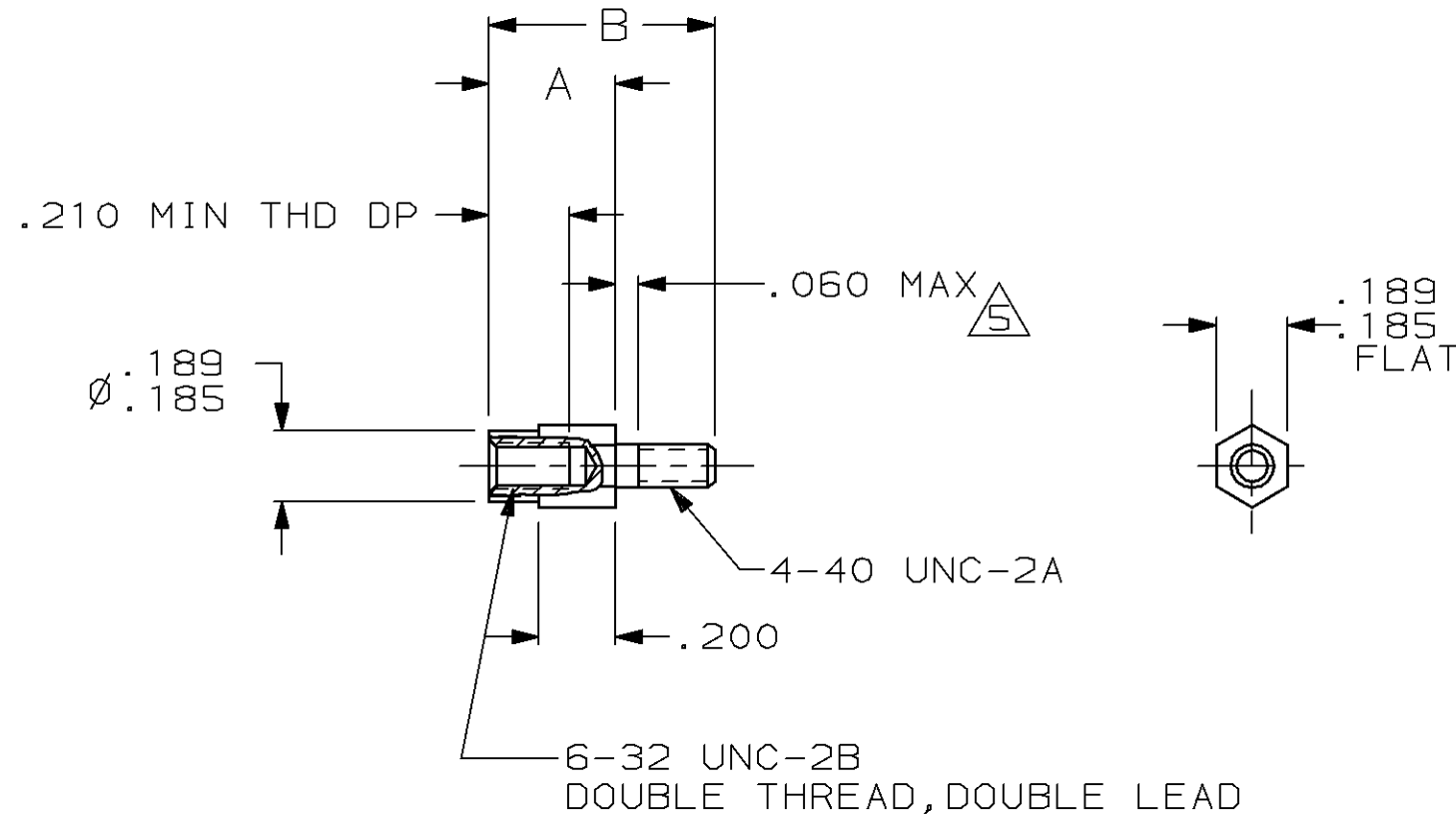

- ① STAINLESS STEEL
- ② CARBON STEEL
- ③ PASSIVATED
- ④ ZINC PLATED PER QQ-Z-325, CLASS 3, TYPE II
- ⑤ NO THREAD REQUIRED THIS LENGTH.

	OBSOLETE	.680	.420	④	②	86937-6
		.589	.330	③	①	86937-3
SUPSD BY 86937-3		.589	.330	④	②	86937-2
		B	A	FINISH	MATERIAL	PART NO.

DO NOT SCALE PRINT. UNLESS SPECIFIED DIMENSIONS IN INCHES. TOLERANCES ON: 2 PLC DEC ± - 3 PLC DEC ± .005 ANGLES ± -		DR 1-26-89 C. OBERMAN	AMP AMP INCORPORATED Harrisburg, Pa. 17105	
MATERIAL	SEE TABLE	CHK 2-15-89 G.D. MILLER		
FINISH	SEE TABLE	APPD 2-15-89 G.D. MILLER	NAME TIP, JACKSCREW, FEMALE, FIXED	
		APPD 2-15-89 W. PARKER	SIZE B	FSCM NO 00779
		PRODUCT SPEC -	DRAWING NO 86937	
		APPLICATION SPEC -	SCALE 2:1	SHEET 1 OF 1
		WEIGHT -		