

LOC		DIST		P		F		ZONE		LTR		REVISIONS		DATE	APPD
CM	53											B	REV PER EC 0730-0051-94	4-28-94	RV

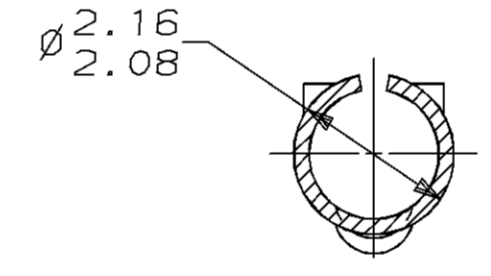

SECTION A-A  
SCALE 10:1

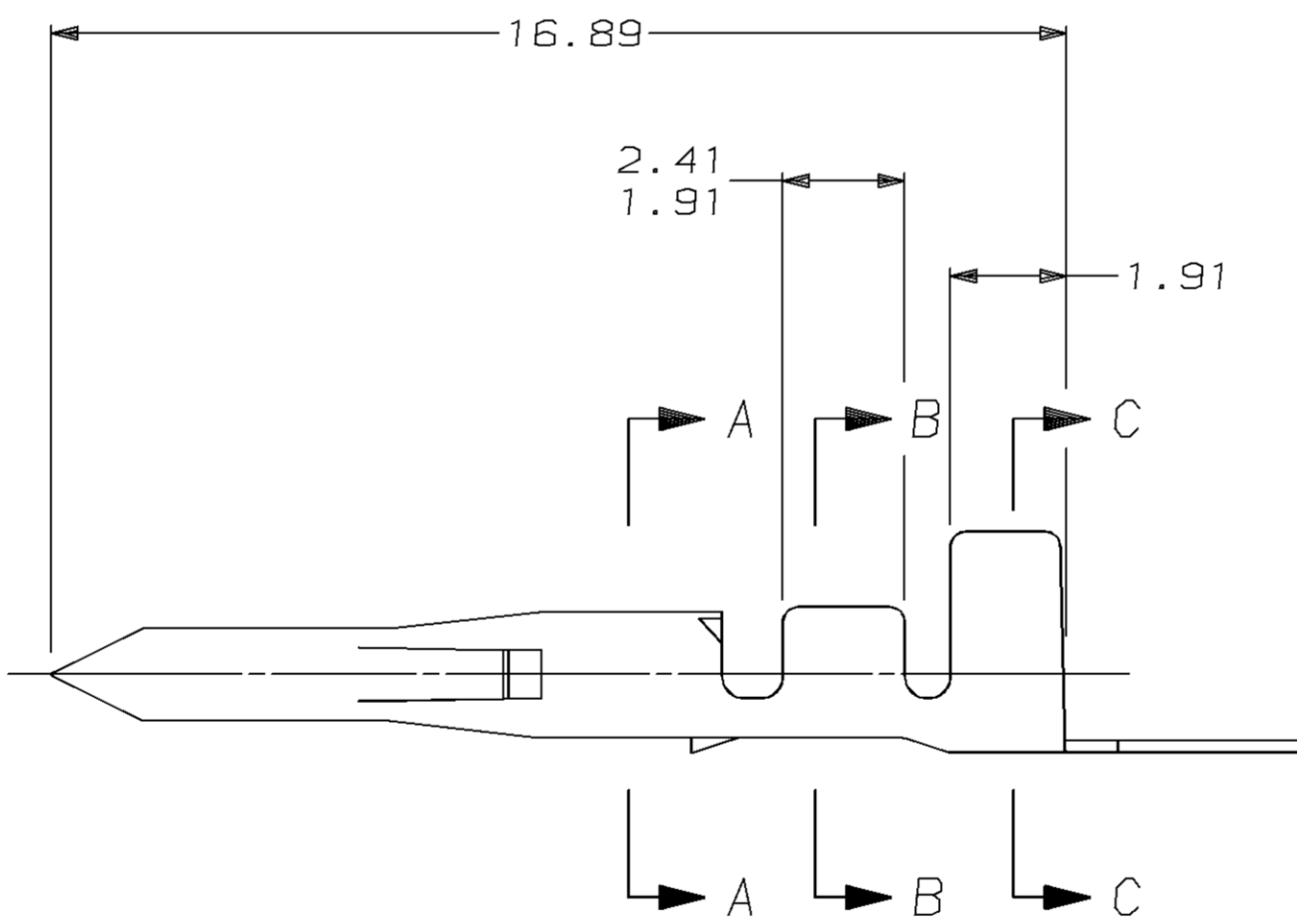
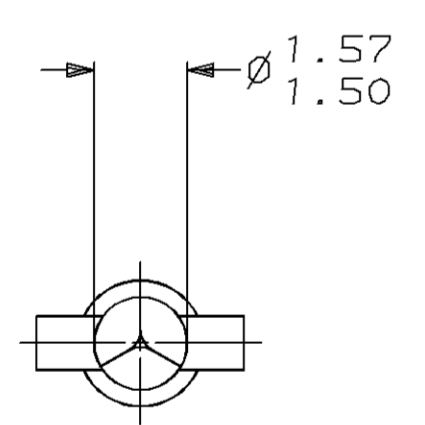
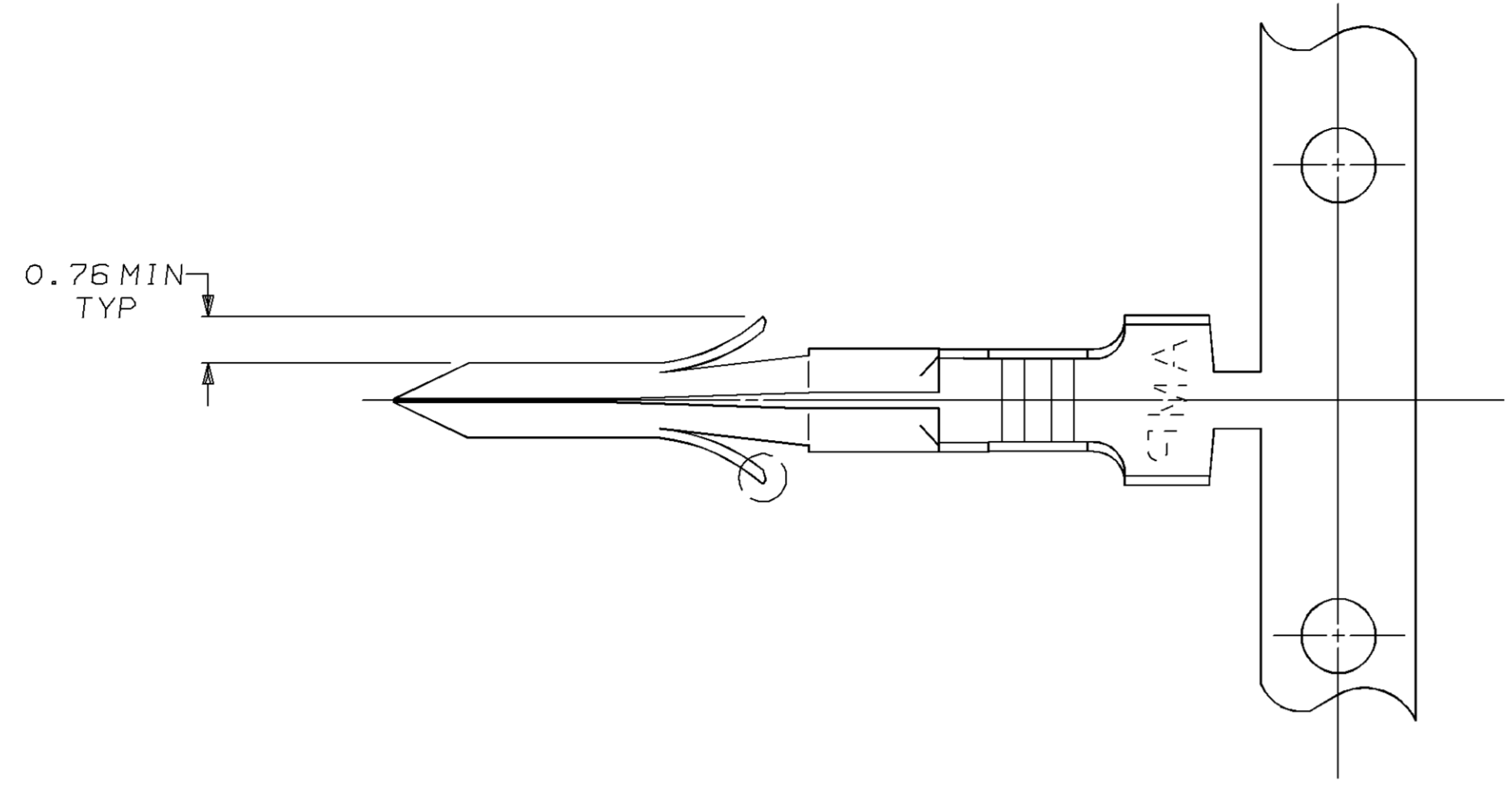
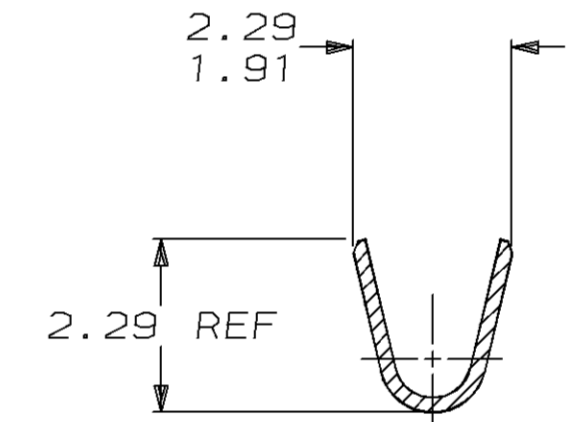

SECTION B-B  
SCALE 10:1

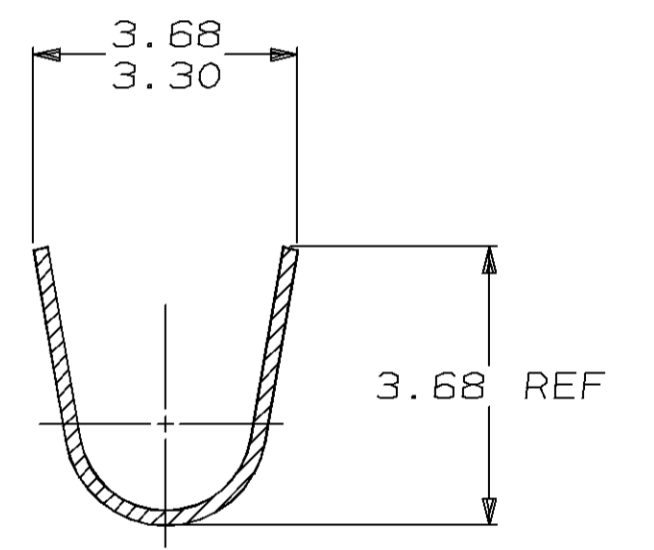

SECTION C-C  
SCALE 10:1

MM	IN	MM	IN	MM	IN
1.57	.062	2.79	.110	-	-
1.50	.059	2.41	.095	-	-
1.27	.050	2.29	.090	-	-
0.76	.030	2.16	.085	16.89	.665
0.20	.008	2.08	.082	3.68	.145
0.13	.005	1.91	.075	3.30	.130
MM	IN	MM	IN	MM	IN

CONVERSION TABLE



PRE-TIN	0.20 BRASS	1.27 - 2.79	0.2 - 0.9 mm <sup>2</sup> (24-18 AWG)	770983-1
FINISH	MATERIAL	INSULATION DIAMETER	WIRE RANGE	PART NO
DO NOT SCALE PRINT. UNLESS SPECIFIED DIMENSIONS IN mm TOLERANCES ON: 2 PLC DEC ± - 3 PLC DEC ± 0.13 ANGLES ± -	DR 7-13-92 K. SALMON CHK 7-13-92 R. SWING	AMP Incorporated Harrisburg, PA 17105-3608		
SEE TABLE	APPD 7-16-92 C. CASH	NAME .062 PIN, COMMERCIAL PIN AND SOCKET		
FINISH	APPLICATION SPEC	SIZE	CAGE CODE	DRAWING NO
SEE TABLE	-	D	00779	770983
WEIGHT	-	SCALE	8:1	SHEET 1 OF 1