

THIS COPY IS PROVIDED ON A RESTRICTED BASIS AND IS NOT TO BE USED IN ANY WAY DETRIMENTAL TO THE INTERESTS OF PANDUIT CORP.

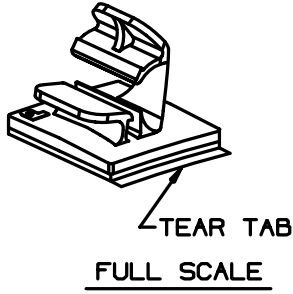
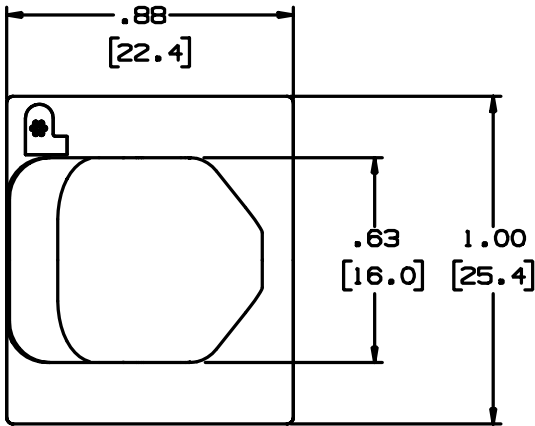

PANDUIT PART NUMBER*	MAXIMUM CABLE DIA. in. (mm)	WEIGHT lbs. (g)/100pcs
LWC25-A	.25 (6.4)	.56 (255)

- NOTES:
- * 1) SEE CURRENT PRICE SHEET FOR PART NUMBER SUFFIX DESIGNATION, FOR PACKAGE SIZE.
 - 2) MOUNT IS DESIGNED TO SUPPORT .45lbs [204g] MAX WEIGHT ON A CLEAN DRY SMOOTH SURFACE.

- TO APPLY LATCHING WIRE CLIP:
1. REMOVE PROTECTIVE LINER
 2. PLACE IN DESIRED LOCATION
 3. APPLY PRESSURE TO TOP OF LATCHING WIRE CLIP

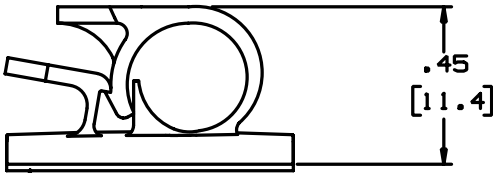

ADHESIVE BACKING: PRESSURE SENSITIVE FOAM .04 [1.0] THICK WITH PROTECTIVE LINER TO EXTEND BEYOND EDGE FORMING A TEAR TAB.

NO WARRANTY, EXPRESSED OR IMPLIED, IS MADE BY PANDUIT WITH RESPECT TO ADHESIVE BOND PERFORMANCE. AMONG OTHER THINGS, THE CONDITIONS UNDER WHICH THESE MOUNTS MAY BE APPLIED, AND/OR THE SURFACE TO WHICH THEY MAY BE APPLIED, ARE BEYOND PANDUIT'S CONTROL.

DIMENSIONS IN BRACKETS ARE METRIC [mm]	
CAD FILENAME/LAYER# GB0285BA_PB_LWC25A_02	
PANDUIT CORP. TINLEY PARK, ILLINOIS	
LWC25-A, LATCHING WIRE CLIP	
UNLESS OTHERWISE SPECIFIED, DIMENSIONAL TOLERANCES ARE: (.X) ±0.05 (1.3) (.XXX) ±0.010 (0.25) (.XX) ±0.02 (0.5) ANGLES ± 5°	UNLESS OTHERWISE SPECIFIED, ALL DIMENSIONS ARE GIVEN IN INCHES, THIRD ANGLE PROJECTION.
DRAWN BY JRJ	MAT'L: NYLON 6/6
DATE 10-19-92	SCALE 2X
DRW'D	DWG NO. GB0285BA
	DWG SIZE A

REV	DATE	BY	CHK	DESCRIPTION	ECN	R	CUST	SUP
2	1-8-98	CGSM		CHANGED NOTE 3 ON APPLICATION INSTRUCTIONS	GB0285BA	2		
1	12-18-92	JRL		CHG. WT. .56 WAS .66 ADDED .56 DIM.	GB0285BA	1		
R	10-19-92	JRJ		INITIAL RELEASE	GB0285BA	R		