

REV.	DATE	ECR NO.	DESCRIPTION
NC	11/02/10	XXXXXX	INITIAL RELEASE

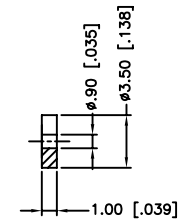
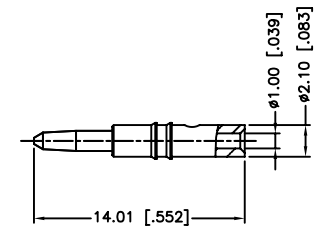
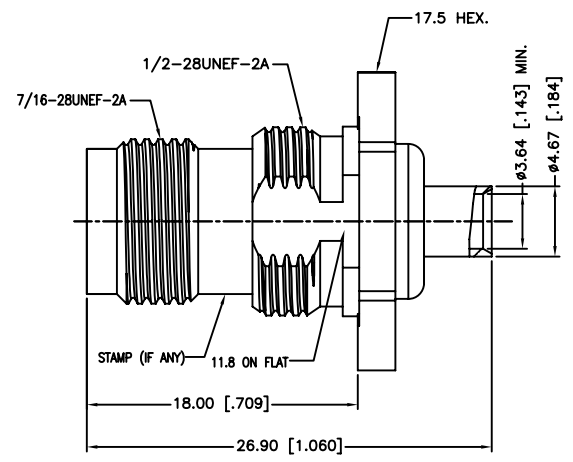
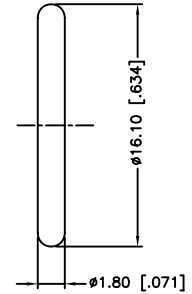
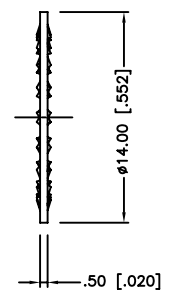
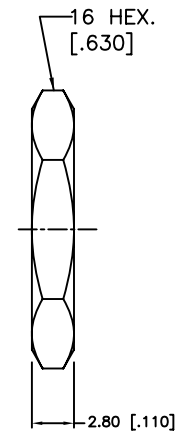
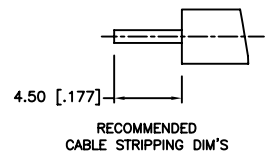
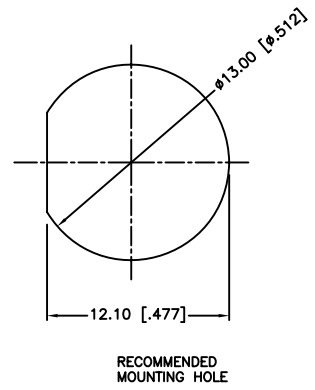

1. CRIMPED CONTACT PIN
HEX CRIMP SIZE .068"
2. MAX. PANEL THICKNESS=3.5mm
3. IP-67 COMPLIANT

10	HEX NUT	BRASS	NICKEL	1
9	LOCK WASHER	BRASS	NICKEL	1
8	GASKET	SILICONE	RED	1
7	INSULATOR	PTFE	NATURAL	1
6	CONTACT PIN	BRASS	GOLD	1
5	BARREL	BRASS	GOLD	1
4	GASKET	N.B.R	BLACK	1
3	O-RING	SILICONE	RED	1
2	INSULATOR	PTFE	NATURAL	1
1	BODY	BRASS	NICKEL	1
	DESCRIPTION	MATERIAL	FINISH	QTY

UNLESS OTHERWISE SPECIFIED DIMENSIONS ARE IN MILLIMETERS. DIMENSIONS IN [] ARE IN INCHES AND FOR CUSTOMER REFERENCE ONLY.

UNLESS OTHERWISE SPECIFIED TOLERANCES FOR MILLIMETERS ARE:
0.5 - 8mm ± 0.20mm
8 - 30mm ± 0.40mm
30 - 120mm ± 0.50mm

UNLESS OTHERWISE SPECIFIED TOLERANCES FOR INCHES ARE:
.020 - .315 = ± 0.007"
.315 - 1.180 = ± 0.015"
1.180 - 4.724 = ± 0.020"

DO NOT SCALE DRAWING

APPROVALS	DATE
DRAWN M.ZHANG	11/02/10
CHECKED	
ISSUED	
SHEET 1 OF 1	
CAD FILE	F:\DWG\CONNEX\122401RP-10.DWG

Amphenol Connex

PART DESCRIPTION
**TNC REVERSE BULKHEAD DIRECT SOLDER JACK
IP-67 COMPLIANT, (FOR .141" CABLE)**

PART NO.
122401RP-10

DWG. NO.	122401RP-10.DWG	REV.	NC	SIZE	A	SCALE	NA
----------	-----------------	------	----	------	---	-------	----