

LOC	DIST	REVISIONS				
P	U/R	DESCRIPTION	DATE	DWN	APVD	
GP	00	L	REV PER EC 0512-0217-03	12MAY03	AWF	AWF

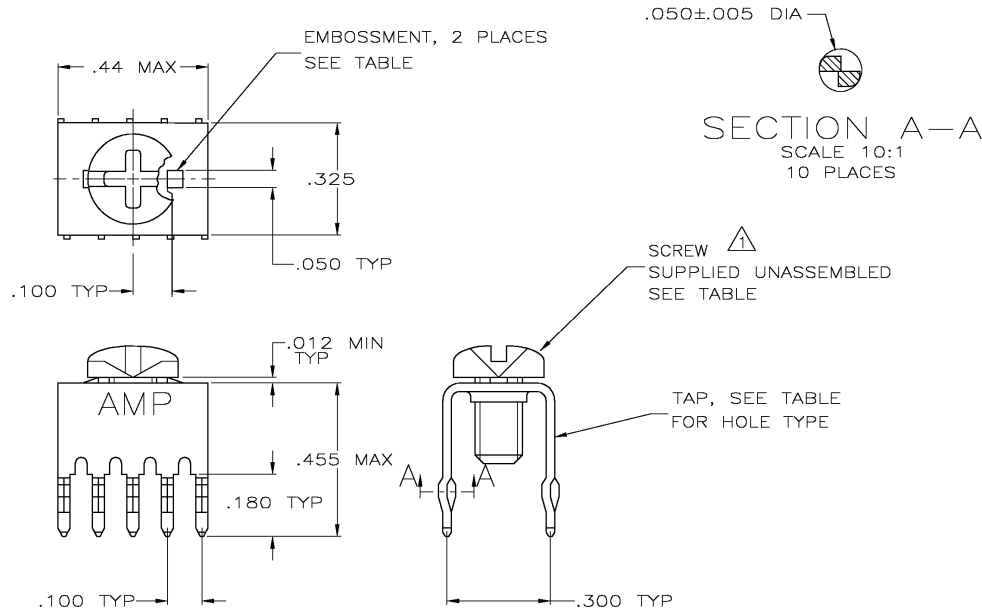

- ① TO PREVENT THREAD STRIPPING, SCREW TORQUE SHOULD NOT EXCEED 9 IN LBS.
- ② TAP HOLE IS 6-32UNC-2B, TWO MIN THREADS.
- ③ TAP HOLE IS M4 X 0.7, TWO MIN THREADS.
- ④ TAP: .000150 TIN-LEAD OVER .000050 NICKEL.
- ⑤ TAP: .000150 TIN OVER .000050 NICKEL.

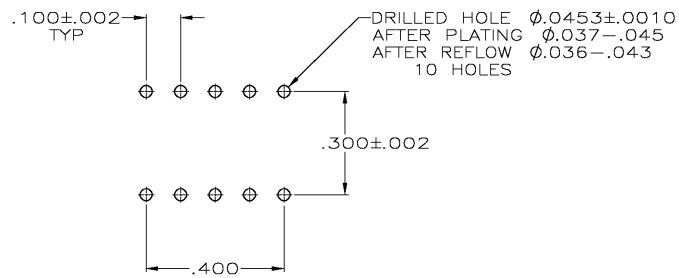

SUPERSEDED BY -4	FINISH	HOLE TYPE	SCREW	EMBOSSMENT	PART NUMBER		
						⑤	②
					993879-1	YES	9-55558-1
					NO	YES	9-55558-0
					NO	YES	1-55558-1
					993879-1	NO	55558-8
					NO	NO	55558-7
					993879-1	YES	55558-4
					NO	YES	55558-3

THIS DRAWING IS A CONTROLLED DOCUMENT.		DWN J. McCLINTON 1-11-88	Tyco Electronics Corporation	
DIMENSIONS: INCHES		CHK R. STONE 1-11-88	City, State, Zip	
TOLERANCES UNLESS OTHERWISE SPECIFIED:		APVD M. GALLOWAY 1-11-88	NAME TAP, POWER DISTRIBUTION	
0 PLC ± -		PRODUCT SPEC	SIZE	
1 PLC ± -		APPLICATION SPEC	EAGE CODE	
2 PLC ± -		WEIGHT	DRAWING NO	
3 PLC ± .008			RESTRICTED TO	
4 PLC ± -			A2 00779	
ANGLES ± -			©-55558	
MATERIAL COPPER ALLOY 725.		FINISH ④⑤	SCALE 4:1 SHEET 1 OF 1 REV L	
		CUSTOMER DRAWING		