

Apr.1.2017 Copyright 2017 HIROSE ELECTRIC CO., LTD. All Rights Reserved.

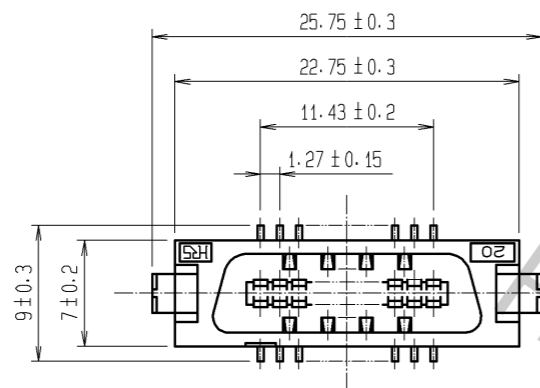

RECOMMENDED LAND PATTERN DIMENSION OF PCB (MOUNTING SIDE)
(RECOMMENDED METAL MASK THICKNESS:0.2mm)

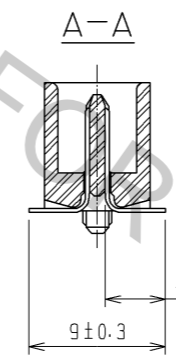
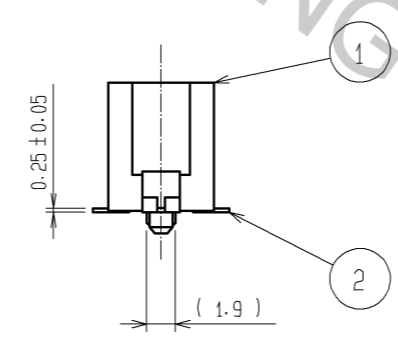
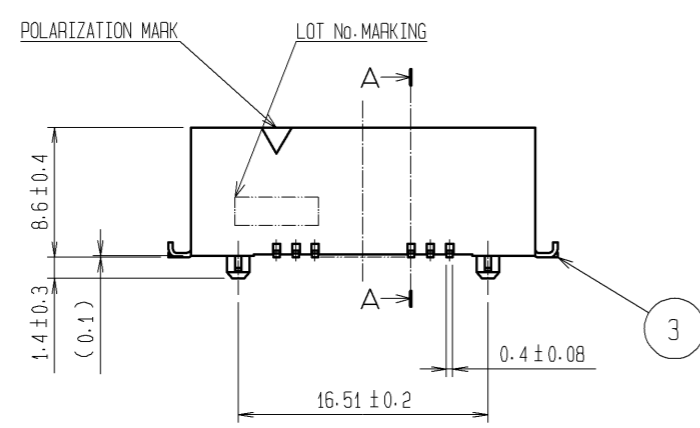
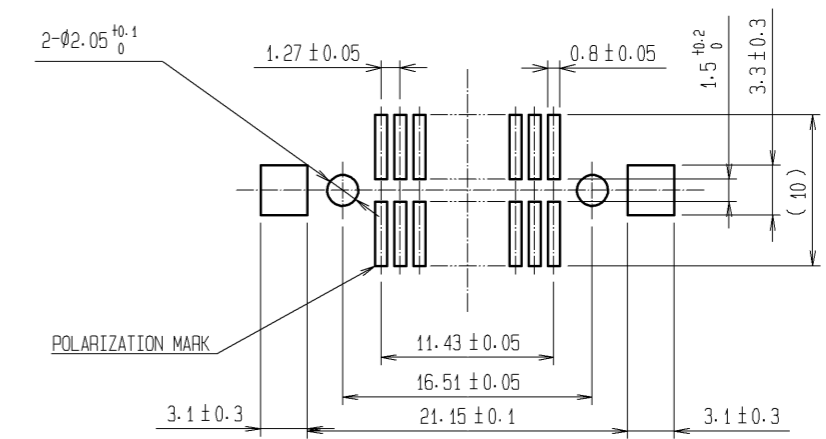

- NOTE 1 LEAD CO-PLANARITY SHALL BE 0.15mm MAX.
 2 THE DIMENSIONS IN PARENTHESES ARE FOR REFERENCE.
 3 TRAY PACKAGING SHALL BE APPLIED TO THIS PRODUCT.
 SEE NEXT PAGE FOR DETAILS.

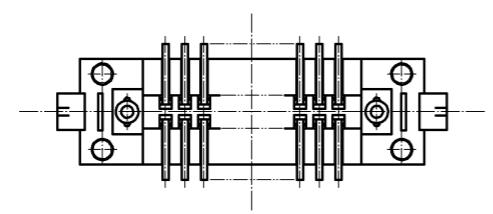

2	PHOSPHOR BRONZE	CONTACT AREA:GOLD 0.2#m min. LEAD AREA:TIN-PLATING 2#m min. UNDER PLATING:NICKEL 2#m min.	4	PS	TRAY			
1	PPS	LIGHT BROWN (UL94V-0)	3	BRASS	TIN-PLATING			
NO.	MATERIAL	FINISH . REMARKS	NO.	MATERIAL	FINISH . REMARKS			
UNITS mm		SCALE 2 : 1	COUNT 	DESCRIPTION OF REVISIONS		DESIGNED	CHECKED	DATE
HRS HIROSE ELECTRIC CO., LTD.		APPROVED : HS. OKAWA	11.06.22	DRAWING NO. EDC3-082752-25				
		CHECKED : HT. YAMAGUCHI	11.06.22	PART NO. FX2-20P-1.27SVL(95)				
		DESIGNED : SY. KAMIGA	11.06.22	CODE NO. CL572-2051-7-95				
		DRAWN : HK. SUNADORI	11.06.21					

DRAWING FOR PACKING(1:2)

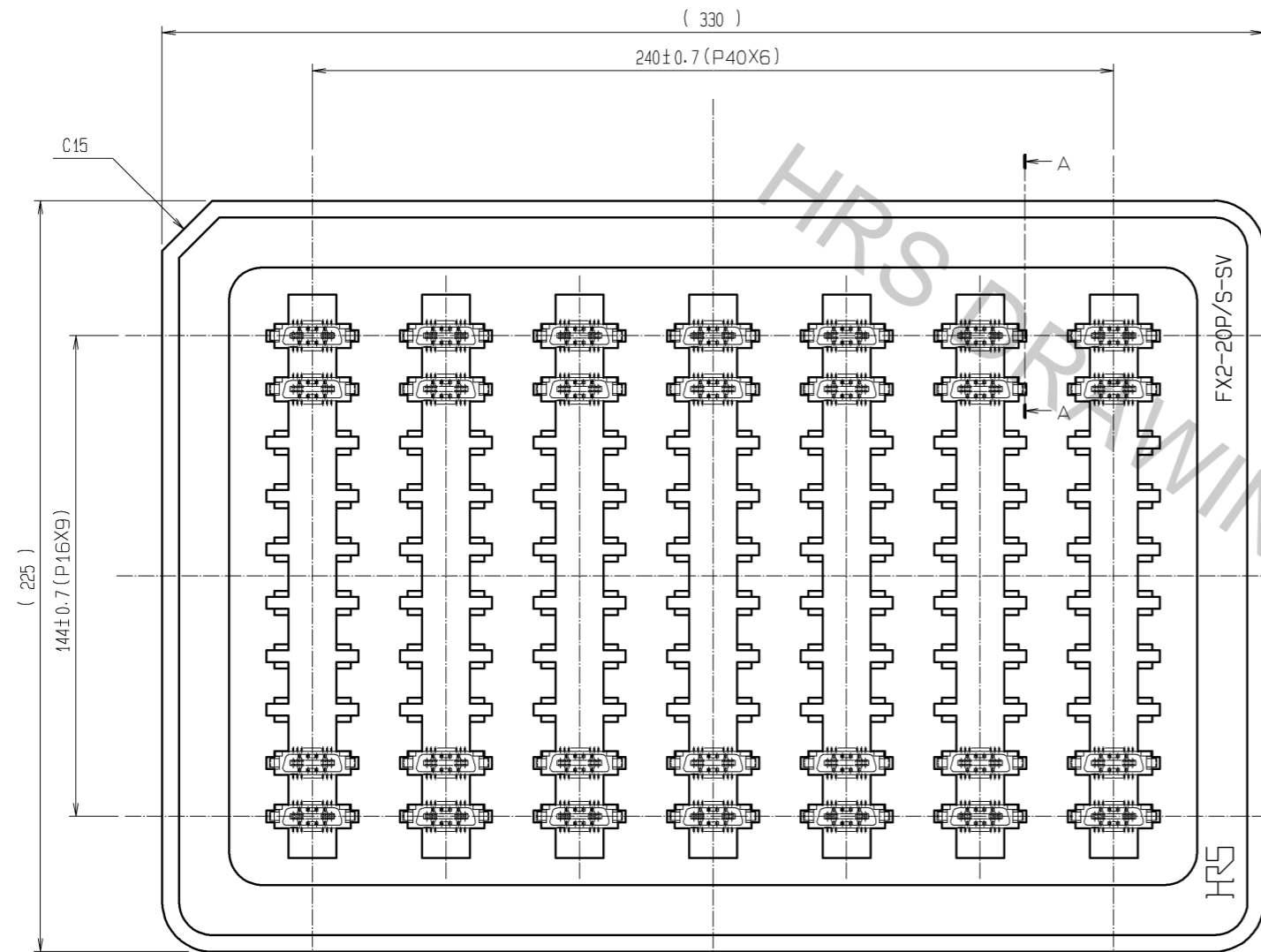

A-A(2:1)

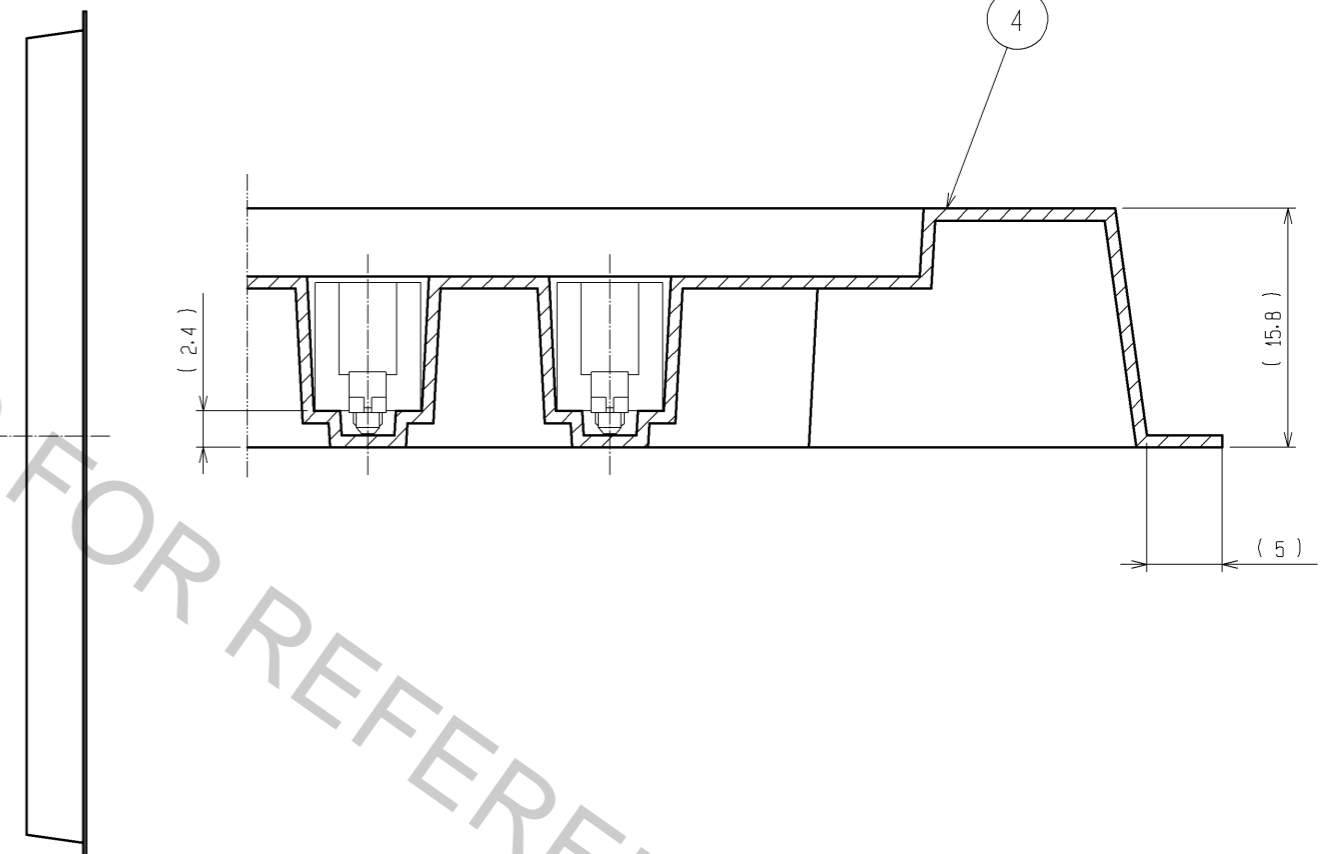

- NOTE 1 1 TRAY:70 CONNECTORS
 2 SETTING POSITION OF CONNECTORS IN THE TRAY SHALL BE ARRANGED IN ACCORDANCE WITH DRAWING.
 3 THE DIMENSIONS IN PARENTHESES ARE FOR REFERENCE.

HRS	DRAWING NO.	EDC3-082752-25
	PART NO.	FX2-20P-1.27SVL(95)
	CODE NO.	CL572-2051-7-95
		\triangle 2/2